



MIL-DTL-38999 Circular Connectors

And 38999-Style Connectors

Withstand Harsh Environments with
Rugged, Capable Connectors for Signal, Power,
Control, and Optical Needs

INTRODUCTION

4

MIL-DTL-38999 CONNECTORS

Series I	18
Series III	30
Series IV	44

MIL-DTL-38999 SERIES III STYLE CONNECTORS

Panel Seals	56
Hermetic Connectors	62
PCB Connectors	
Board-Mount 38999 Connectors	65
Marine Connectors	
DEUTSCH DTS-B Connectors	102
Band It Platform Connectors	
Aluminum and Stainless Steel Connectors with Integral Backshells	110
Power Connectors	
DEUTSCH DTS-HC Connectors	120
POLAMCO Connectors	125
Lanyard Connectors	
1760 Series Connectors (MIL-DTL-38999/31 and ACT98 and commercial /29)	137
Ultra-Dense Connectors	
DEUTSCH Wildcat 38999 Connectors	138
38999 Series 1.5 Connectors	
DEUTSCH HDJ/JN1003 Series Connectors	144
High-Speed Connectors	
Quadrax Connectors	156
CeeLok FAS-X Connectors	173
High-Speed COTS Interface Connectors	
POLAMCO USB Connectors	186
POLAMCO RJ45 Connectors	189
Fiber-Optic Connectors	
Introduction	193
MC801 Connectors	195
DEUTSCH MC3 MKII Connectors	199
DEUTSCH MC4 Connectors	205
DEUTSCH MC5 Connectors	211
DEUTSCH MC6 Connectors	217
AviMT Connectors	224
38999-Style Connectors	226
PRO BEAM Inserts	233
MIL-T-29504 Style Optical Termini	235
Backshells and Rear Accessories	237
Specialty Connectors	
DEUTSCH CBC Bussed Connectors	281
Assembly Instructions	286

TE Components . . . TE Technology . . . TE Know-how . . .

AMP | AGASTAT | CII | HARTMAN | KILOVAC | MICRODOT | NANONICS | POLAMCO | Raychem
SEACON | Rochester | DEUTSCH

Empower Engineers to Solve Problems, Moving the World Forward.



MIL-DTL-38999 Connectors

MIL-DTL-38999 Series	Coupling	DEUTSCH Connector Family	Shell Material
Series I	Bayonet	DJT	Aluminum
		DTS	Aluminum
Series III	Threaded	DTS-K, DTS-L, DTS-S	Stainless steel
		ACT	Composite
Series IV	Breech lock	DIV	Aluminum

MIL-DTL-38999 Series III Style Connectors

Marine Connectors	
DEUTSCH DTS-B Connectors	Marine bronze shell
High-Speed Connectors	
Quadrax Connectors	2 Gb/s
CeeLok FAS-X Connectors	10 Gb/s, 1 or 4 Ethernet channels
High-Speed COTS Interface Connectors	
POLAMCO RJ45 Connectors	Cat 6a
POLAMCO USB Connectors	USB 2.0 and 3.0
Power Connectors	
DEUTSCH DTS-HC Connectors	Up to 300 A
POLAMCO Connectors	Up to 1000 A
Lanyard Connectors	
1760 Series Connectors (MIL-DTL-38999/31 and ACT98 and commercial /29)	MIL-STD-1760 Types 1 and 2
PCB Connectors	
Board-Mount 38999 Connectors	
Fiber-Optic Connectors	
DEUTSCH MC3 MKII Connectors	DEUTSCH 2.5 mm termini
DEUTSCH MC4 Duplex Connectors	2.5 mm termini, compact Size 9 shell
DEUTSCH MC5 Connectors	DEUTSCH 1.25 mm termini
DEUTSCH MC6 Connectors	MT ferrule
MC801 Connectors	ARINC 801 termini
QPL Connectors	MIL-PRF-29504/4 and /5 termini
EB16 Connectors	EB16 contacts
PRO BEAM Inserts	Expanded beam termini
Ultra-Density Connectors	
DEUTSCH Wildcat 38999 Connectors	Nearly twice the contact density over standard Series III
Specialty Connectors	
DEUTSCH CBC Bussed Connectors	Internal contact bussing for grounding or power distribution
DEUTSCH Grounding Connectors	
38999 Series 1.5 Connectors	
DEUTSCH HDJ/JN1003 Series Connectors	38999 Series I bayonet coupling interface lengths and Series II diameters
Hermetic Connectors	
Overview/Capabilities	

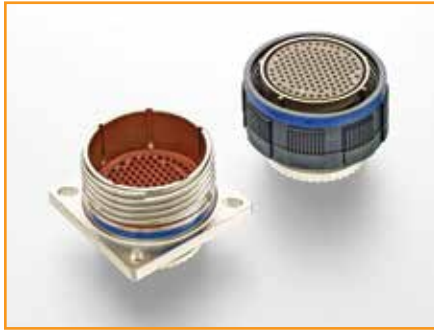

38999 Overview

MIL-DTL-38999 connectors are some of the most popular and widely used subminiature circular connectors for military and aerospace applications. With three coupling methods, nine shell sizes, and a wide variety of contact arrangements, the connectors help give you the range of choices you need. What's more, the original aluminum connectors have evolved to include stainless steel and composite shells—supported by a range of finishes.

38999-Style Connectors

Because of the widespread popularity of 38999 Series III connectors, the basic design has been adapted to a great many additional configurations. These 38999-style connectors include versions for power, fiber optics, filtering, high-speed networking, commercial interfaces, pc board interfaces, and higher contact densities. As a result, 38999-style connectors offer excellent versatility and flexibility.



Rugged Reliability

When it comes to taming harsh environments, TE Connectivity (TE) offers 38999 connectors to handle a wide range of applications. We offer a broad array of configurations, materials and finishes to help meet the performance requirements of ground, aerospace, and marine applications. These highly durable subminiature circular connectors are time tested for reliability in some of the toughest environments.



TE helps meet the need for reliable performance with rugged MIL-DTL-38999 connectors having 500 mating cycles, operating temperatures to 200°C, corrosion-resistant and corrosion-proof connector versions, scoop-proof designs, and a variety of options for excellent electromagnetic interference (EMI) control, such as filtering and fiber optics.

Designs that Save Space and Weight

The importance of reducing size and weight of components, including MIL-DTL-38999 subminiature connectors, should never be underestimated. Lighter, smaller connectors can make a big difference in terms of contributing to greater performance: longer flight times, greater payload capability, and increased efficiency. Beyond the standard lightweight aluminum connectors, we offer composite connectors to help support greater weight savings.



Solve Tough Application Issues with TE

We work closely with customers to help meet their most demanding requirements for some of the world's toughest applications. Whether for ground defense, commercial and military aerospace, or marine applications, TE designs and manufactures MIL-DTL-38999 subminiature circular connectors to be ruggedly reliable, fast and easy to install, smaller and lighter, and with more options, materials and configurations to help maximize performance, reliability and efficiency.



MIL-DTL-38999 Connector Series Overview

	Series I	Series III	Series IV
Coupling Mechanism	Bayonet, 1/3 turn	Threaded, 360° turn	Breech lock, 1/4 turn
Shell Materials	Aluminum Stainless steel	Aluminum Stainless steel Composite	Aluminum Stainless steel
Finishes	Olive drab cadmium Passivated Electroless nickel Electrodeposited nickel Nickel PTFE Black zinc nickel	Olive drab cadmium Passivated Electroless nickel Electrodeposited nickel Nickel PTFE Black zinc nickel	Olive drab cadmium Passivated Electroless nickel
Shell Sizes	9, 11, 13, 15, 17, 19, 21, 23, 25	9, 11, 13, 15, 17, 19, 21, 23, 25	11, 13, 15, 17, 19, 21, 23, 25
No. of Signal Contacts, Max.	128	187	128
Contact Sizes, Std.	22, 20, 16, 12, 8	23, 22, 20, 16, 12, 10, 8	22, 20, 16, 12, 8
Contact Type	SAE AS39029		
Contact Styles	Crimp PCB tail Solder cup** Eyelet**		
Features	Scoop proof Environmentally sealed Hermetic versions Filter versions Spring fingers for EMI control		
Operating Temperatures	-65°C to +200°C -65°C to +175°C -65°C to +150°C		
Durability (Mating Cycles)	500 ACT composite Series III: 1500*		

*Achievable only with high durability contacts or by replacing them each 500 cycles

** Hermetic versions only



Shell Materials and Finishes

Class	Plating/Finish	Finish Spec	Temperature (Max.)	Salt Spray (Hours)	Series	Shell-to-Shell Conductivity (mV Drop)	RoHS Compliant
Aluminum Shells							
B	Olive Drab Cadmium	QQ-P-416	+175°C	500	I	2.5	No
F	Electroless Nickel	ASTM B733	+200°C	48	I, III, IV	1.0	Yes
G	Electroless Nickel, Space Grade	ASTM B733	+200°C	48	I, III, IV	1.0	Yes
T	Nickel PTFE	QQ-N-290	+175°C	500	I, III, IV	2.5	Yes
W	Olive Drab Cadmium	QQ-P-416	+175°C	500	III, IV	2.5	No
Z	Black Zinc Nickel	ASTM B841	+175°C	500	I, III, IV	2.5	Yes
Stainless Steel Shells							
K	Passivated	—	+260°C	500	III	10	Yes
L	Electrodeposited Nickel	QQ-N-290	+200°C	500	III	1.0	Yes
S	Electrodeposited Nickel	QQ-N-290	+200°C	500	III	1.0	Yes
Composite Shells							
J	Olive Drab Cadmium	ASTM B733	+175°C	2000	III	3.0	No
M	Electroless Nickel	QQ-N-290	+200°C	2000	III	3.0	Yes
Hermetic Connectors (Stainless Steel Shell)							
Y	Passivated	—	+200°C	500	III, IV	10.0	Yes
N	Electrodeposited Nickel	QQ-N-290	+200°C	500	I, III, IV	1.0	Yes
H	Electroless Nickel, Space Grade	QQ-N-290	+200°C	500	III, IV	10.0	Yes

Service Rating

Service Rating	Suggested Operating Voltage		Test Voltage at Altitude (VAC _{rms})			
	VAC _{rms}	VDC	Sea Level	50,000 Ft	70,000 Ft.	100,000 Ft
M	400	550	1300	550	350	200
N	300	450	1000	400	260	200
I	600	850	1800	600	400	200
II	750	1050	2300	800	500	200



Shell Materials

TE 38999 connectors are available with aluminum, stainless steel, and composite shells. In addition, we offer 38999-style connectors in marine bronze.

Aluminum	<p>Aluminum offers a favorable balance of performance, weight, and cost</p> <ul style="list-style-type: none"> Most widely used material Light weight Excellent corrosion resistance Available in all finishes Rugged
Stainless Steel	<p>Stainless steel is used for hermetic connectors or for connectors used in high-temperature environments, including engines and firewalls</p> <ul style="list-style-type: none"> Passivated or nickel finish
Composite	<p>Composite shells offer the lightest weight and highest corrosion resistance</p> <ul style="list-style-type: none"> Weight savings of up to 40% over aluminum and 70% over stainless steel Corrosion proof: passes 2000-hour salt spray test 1500-mating-cycle durability
Marine Bronze	<p>With excellent corrosion resistance, aluminum nickel bronze is popular for marine applications</p> <p>Unplated marine bronze helps eliminate the danger of wear to plating that could expose the underlying material to corrosion.</p> <p>See the section on DEUTSCH DTS-B series connectors.</p>

Space-Grade Connectors

Outgassing—the release of gases trapped in a solid—of polymer materials such as connector inserts, seals, adhesives, or potting materials, is an issue since the gases can degrade performance of charge-coupled-device (CCD) sensors in satellites, thermal radiators, or solar cells. Outgassing is a challenge to creating and maintaining clean high-vacuum environments. The closed environment of spacecraft can make outgassing a greater concern. Our space-grade connectors use low-outgassing materials to help meet requirements for a Total Mass Loss of 1.00% or less and a Collected Volatile Condensable Material (CVCM) of 0.10% or less.

Materials can be processed to help meet NASA requirements for low outgassing by oven backout in a thermal vacuum environment.

Aluminum, with an electroless nickel finish, is usually the preferred shell material. Its low magnetic permeability helps prevent it from becoming magnetized.





Connector Styles

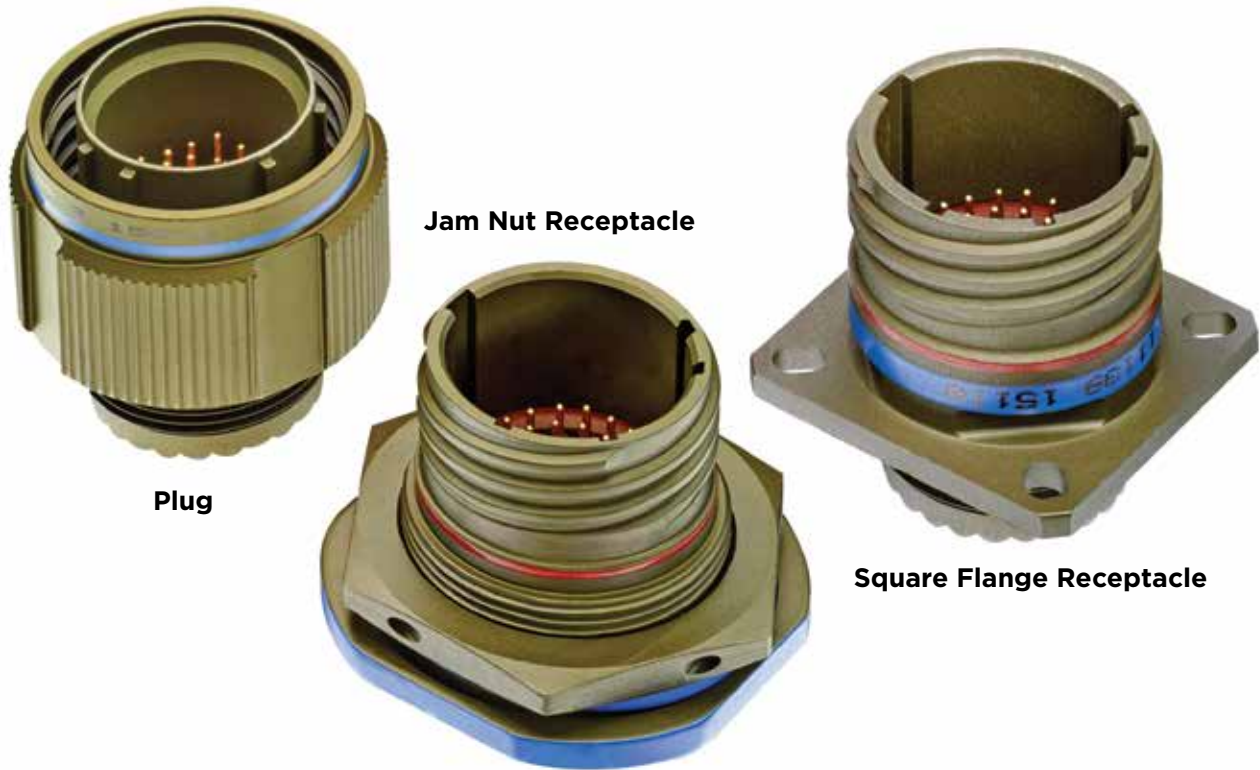

Plug

Plugs are free-hanging cable-mount halves of a connection. They contain the coupling ring used to secure the plug to the receptacle.

Jam Nut Receptacle

Jam nuts are the preferred style for creating an environmentally sealed mounting. Single-hole mounting and an integral o-ring allows a sealed mounting with a single hex nut threaded onto the front of the connector to secure it in place. Jam nut receptacles are rear-mount connectors.

Square Flange Receptacle

These standard receptacles have a relatively large four-hole flange for front or rear mounting to a bulkhead or panel.



Typical Constructions

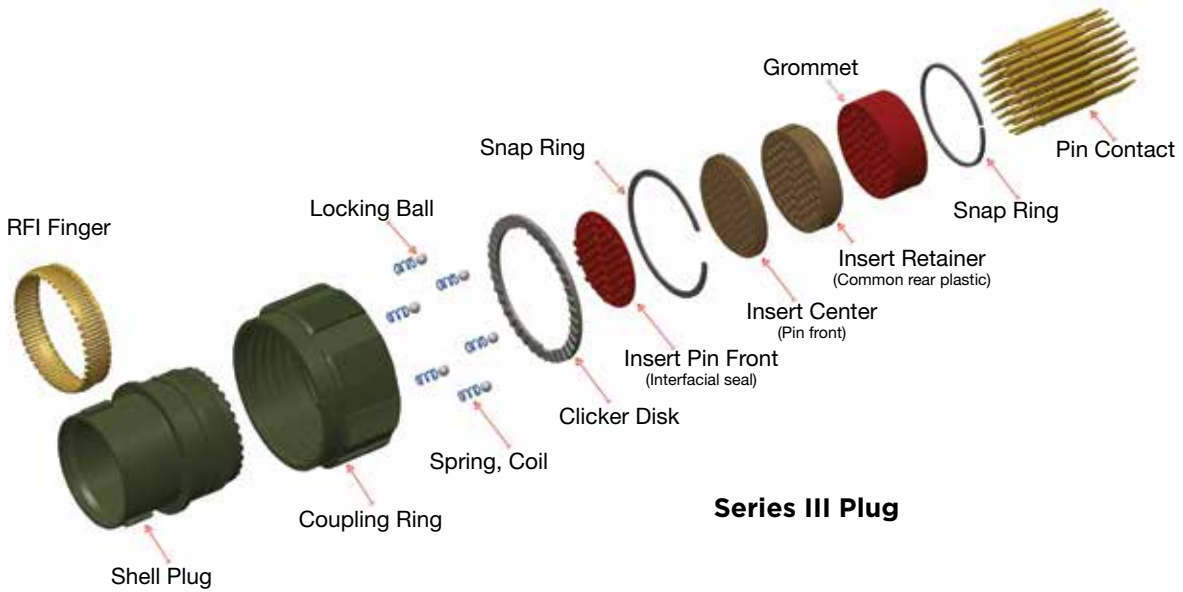
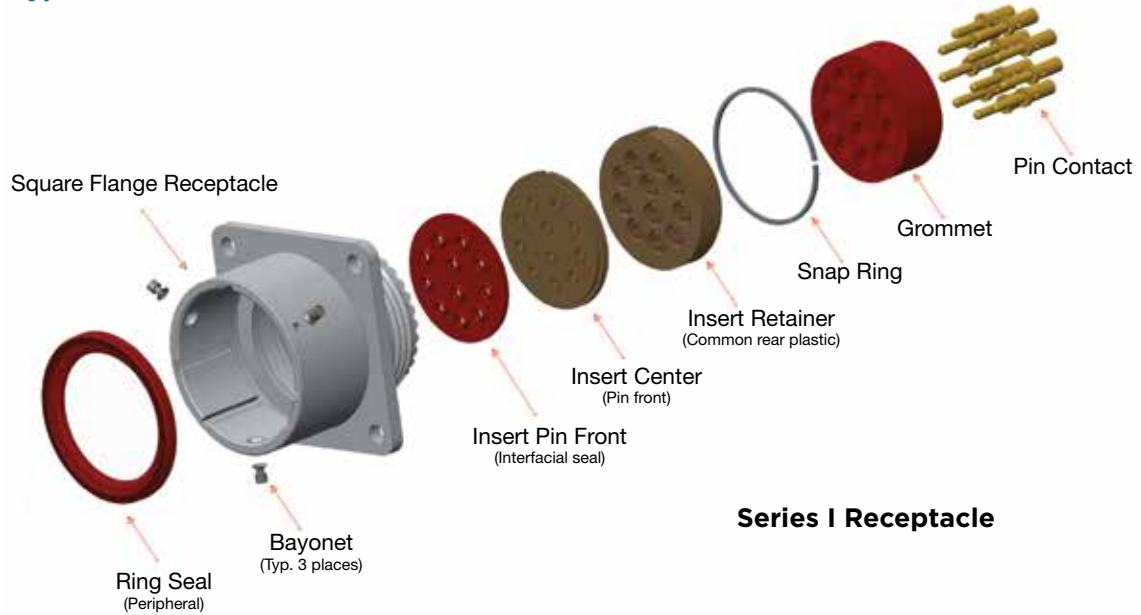



Insert Arrangements

The drawings in this section use numeric shell sizes. MIL-DTL-38999 uses letter in place of shell size in the part number system. Thus, 9-35 and A35 describe the same insert arrangement.

Shell Size	9	11	13	15	17	19	21	23	25
Military Designation	A	B	C	D	E	F	G	H	J

Shell Size 9



Insert Configuration Series	09-06 7 Size 22M Contacts I, III	09-07 7 Size 22D Contacts I, III	09-23 9 Size 23 Contacts III	09-35 6 Size 22D Contacts I, III, EN
Service Class	M	M	N	M
QPL	Yes	—	—	Yes
Class K QPL/S	—	—	—	Yes
Hermetic	Yes	—	—	Yes



Insert Configuration Series	09-98 3 Size 20 Contacts I, III, EN
Service Class	I
QPL	Yes
Class K QPL/S	Yes
Hermetic	Yes

Shell Size 11



Insert Configuration Series	11-01 1 Size 8 Contact III, EN	11-02 2 Size 16 Contacts I, III, IV	11-04 4 Size 20 Contacts I, III, IV, EN	11-05 5 Size 20 Contacts I, III, IV, EN
Service Class	N	I	I	I
QPL	—	Yes (Series I, III)	Yes	Yes
Class K QPL/S	—	—	—	—
Hermetic	—	Yes	Yes	Yes



Insert Configuration Series	11-12 1 Size 12 Contact III, EN	11-13 13 Size 22M Contacts I, III, IV	11-23 19 Size 23 Contacts III	11-35 13 Size 22D Contacts I, III, IV, EN
Service Class	II	M	N	M
QPL	—	Yes	—	Yes
Class K QPL/S	—	—	—	Yes
Hermetic	—	Yes	—	Yes



Insert Configuration Series	11-98 6 Size 20 Contacts I, III, IV, EN	11-99 7 Size 20 Contacts I, III, IV, EN
Service Class	I	I
QPL	Yes	Yes
Class K QPL/S	Yes	Yes
Hermetic	Yes	Yes



Shell Size 13

Insert Configuration Series	13-04 4 Size 16 Contacts I, III, IV, EN	13-08 8 Size 20 Contacts I, III, IV, EN	13-22* 22 Size 22M Contacts I, III, IV	13-23 32 Size 23 Contacts I, III, IV
Service Class	I	I	M	N
QPL	Yes	Yes	Yes	—
Class K QPL/S	—	Yes	—	—
Hermetic	Yes	Yes	Yes	—
Insert Configuration Series	13-35 22 Size 22D Contacts I, III, IV, EN	13-98 10 Size 20 Contacts I, III, IV, EN		
Service Class	M	I		
QPL	Yes	Yes		
Class K QPL/S	Yes	Yes		
Hermetic	Yes	Yes		

*Inactive for new designs

Shell Size 15

Insert Configuration Series	15-05 5 Size 16 Contacts I, III, IV, EN	15-15 14 Size 20 Contacts I, III, IV, EN	15-18 18 Size 20 Contacts I, III, IV, EN	15-19 19 Size 20 Contacts I, III, IV, EN
Service Class	II	I	I	I
QPL	Yes	Yes	Yes	Yes
Class K QPL/S	Yes	—	Yes	Yes
Hermetic	Yes	Yes	Yes	Yes
Insert Configuration Series	15-21 1 Size 12 Coax Contact 3 Size 20 Contacts 17 Size 22D Contacts	15A23 4 Size 16 Coax Contacts 3 Size 20 Contacts 19 Size 22D Contacts	15-23 55 Size 23 Contacts	15-26 2 Size 16 Contacts 24 Size 22D Contacts
Series	I, III, IV	III	III	I, III, IV
Service Class	I	N	N	M
QPL	—	—	—	—
Class K QPL/S	—	—	—	—
Hermetic	—	—	—	—
Insert Configuration Series	15-35 37 Size 22D Contacts	15-37 37 Size 22M Contacts	15-97 4 Size 12 Contacts 8 Size 20 Contacts	
Series	I, III, IV, EN	I, III, IV	I, III, IV, EN	
Service Class	M	M	I	
QPL	Yes	Yes	Yes	
Class K QPL/S	Yes	—	Yes	
Hermetic	Yes	Yes	Yes	



Shell Size 17

Insert Configuration	17-02* 1 Size 8 Twinax Contact 38 Size 22D Contacts	17-03 1 Size 8 Twinax 38 Size 22D Contacts	17-06 6 Size 12 Contacts	17-08 8 Size 16 Contacts
Series	I, III, IV, EN	I, III, IV	I, III, IV, EN	I, III, IV, EN
Service Class	M	M	I	II
QPL	—	—	Yes	Yes
Class K QPL/S	—	—	Yes	Yes
Hermetic	—	—	Yes	Yes
Insert Configuration	17-11 2 Size 12 Twinax 1 Size 12 Coax 8 Size 20 Contacts	17-19 4 Size 16 Contacts 11 Size 20 Contacts 4 Size 22D Contacts	17-20 4 Size 12 Contacts 16 Size 22D Contacts	17-22 2 Size 8 Twinax 2 Size 10 Contacts
Series	I, III, IV	I, III, IV	I, III, IV, EN	I, III, IV, EN
Service Class	N	N	N	N
QPL	—	—	—	—
Class K QPL/S	—	—	—	—
Hermetic	—	—	—	—
Insert Configuration	17-23 73 Size 23 Contacts	17-24 2 Size 8 Power 2 Size 12 Contacts	17-26 26 Size 20 Contacts	17-28 2 Size 8 Twinax
Series	III	I, III, IV	I, III, IV, EN	I, III, IV, EN
Service Class	N	N	I	Twinax
QPL	—	—	Yes	Yes
Class K QPL/S	—	—	Yes	—
Hermetic	—	—	Yes	—
Insert Configuration	17-35 55 Size 22D Contacts	17-55 55 Size 22M Contacts	17-99 2 Size 16 Contacts 21 Size 20 Contacts	
Series	I, III, IV, EN	I, III, IV	I, III, IV, EN	
Service Class	M	M	I	
QPL	Yes	Yes	Yes	
Class K QPL/S	Yes	—	No	
Hermetic	Yes	Yes	Yes	

*Inactive for new designs



Shell Size 19

Insert Configuration	19-11 11 Size 16 Contacts	19-18* 4 Size 8 Twinax 14 Size 20 Contacts	19-19 4 Size 8 Twinax 14 Size 20 Contacts	19-28 2 Size 16 Contacts 26 Size 20 Contacts
Series	I, III, IV, EN	I, III, IV	I, III, IV	I, III, IV
Service Class	II	M	M	I
QPL	Yes	—	—	—
Class K QPL/S	Yes	—	—	—
Hermetic	Yes	—	—	Yes
Insert Configuration	19-32 32 Size 20 Contacts	19-35 66 Size 22D Contacts	19-66* 66 Size 22M Contacts	
Series	I, III, IV, EN	I, III, IV, EN	I, III, IV	
Service Class	I	M	M	
QPL	Yes	Yes	Yes	
Class K QPL/S	Yes	Yes	—	
Hermetic	Yes	Yes	Yes	

*Inactive for new designs



Shell Size 21

Insert Configuration	21-01* 79 Size 22M Contacts	21-11 11 Size 12 Contacts	21-16 16 Size 16 Contacts	21-20 2 Size 8 Twinax 18 Size 20 Contacts
Series	I, III, IV	I, III, IV, EN	I, III, IV, EN	I, III, IV, EN
Service Class	I	I	II	M
QPL	Yes	Yes	Yes	—
Class K QPL/S	—	—	Yes	—
Hermetic	Yes	Yes	—	—
Insert Configuration	21-23 121 Size 23 Contacts	21-35 79 Size 22D Contacts	21-39 2 Size 16 Contacts 37 Size 20 Contacts	21-41 41 Size 20 Contacts
Series	I, III	I, III, IV, EN	I, III, IV, EN	I, III, IV, EN
Service Class	N	M	I	I
QPL	—	Yes	Yes	Yes
Class K QPL/S	—	Yes	Yes	Yes
Hermetic	—	Yes	Yes	Yes
Insert Configuration	21-48 4 Size 8 Power	21-75* 4 Size 8 Twinax	21-76 4 Size 8 Twinax	
Series	I, III, IV	I, III, IV, EN	I, III, IV	
Service Class	—	Twinax	Twinax	
QPL	—	Yes	—	
Class K QPL/S	—	—	—	
Hermetic	—	—	—	

*Inactive for new designs



Shell Size 23

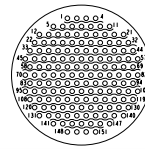
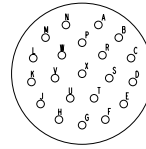
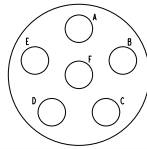
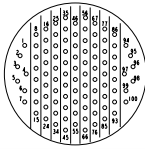

Insert Configuration	23-01* 100 Size 22M Contacts	23-06 6 Size 8 Twinax	23-21 21 Size 16 Contacts	23-23 151 Size 23 Contacts
Series	I, III, IV	I, III, IV, EN	I, III, IV, EN	III
Service Class	M	M	II	N
QPL	Yes	—	Yes	—
Class K QPL/S	—	—	—	—
Hermetic	Yes	Yes	Yes	—

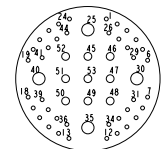
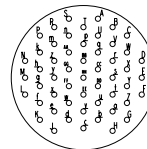
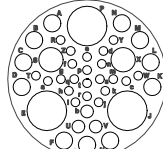
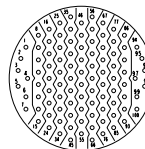

Insert Configuration	23-35 100 Size 22D Contacts	23-41 3 Size 8 Contacts 3 Size 12 Contacts 11 Size 16 Contacts 3 Size 20 Contacts 22 Size 22D Contacts	23-53 53 Size 20 Contacts	23-54 4 Size 12 Contacts 9 Size 16 Contacts 40 Size 22D Contacts
Series	I, III, IV, EN	III, EN	I, III, IV, EN	I, III, IV, EN
Service Class	M	N	I	M
QPL	Yes	—	Yes	—
Class K QPL/S	—	—	Yes	—
Hermetic	Yes	—	Yes	—

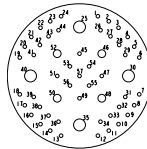
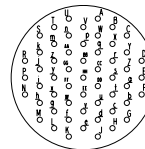

Insert Configuration	23-55 55 Size 20 Contacts	23-63 4 Size 12 Contacts 4 Size 16 Contacts 49 Size 22D Contacts
Series	I, III, IV, EN	I, III, IV
Service Class	I	M
QPL	Yes	—
Class K QPL/S	—	—
Hermetic	Yes	—

*Inactive for new designs



Shell Size 25

Insert Configuration	25-01* 128 Size 22D Contacts	25-04 8 Size 16 Contacts 48 Size 20 Contacts	25-07* 2 Size 8 Twinax 97 Size 22D Contacts	25-08* 8 Size 8 Twinax
Series	I, III, IV	I, III, IV, EN	I, III, IV, EN	I, III, IV, EN
Service Class	M	I	M	Twinax
QPL	Yes	Yes	—	—
Class K QPL/S	—	Yes	—	—
Hermetic	Yes	Yes	—	—
Insert Configuration	25-09 2 Size 8 Twinax 97 Size 22D Contacts	25-10 8 Size 8 Twinax	25-11 9 Size 10 Contacts 2 Size 20 Contacts	25-17 6 Size 8 Twinax 36 Size 22D Contacts
Series	I, III, IV	I, III, IV	I, III, IV, EN	I, III, IV, EN
Service Class	M	Twinax	N	N
QPL	—	—	—	—
Class K QPL/S	—	—	—	—
Hermetic	—	—	—	—
Insert Configuration	25-19 19 Size 12 Contacts	25-20 3 Size 8 Twinax 4 Size 12 Coax 13 Size 16 Contacts 10 Size 20 Contacts	25-21 3 Size 8 Twinax 4 Size 12 Coax 13 Size 16 Contacts 10 Size 20 Contacts	25-23 187 Size 22D Contacts
Series	I, III, IV, EN	I, III, IV, EN	I, III, IV	I, III, IV
Service Class	I	N	N	N
QPL	Yes	Yes	Yes	—
Class K QPL/S	—	—	—	—
Hermetic	Yes	—	—	—

*Inactive for new designs



Shell Size 25

Insert Configuration	25-24 12 Size 12 Contacts 12 Size 16 Contacts	25-29 29 Size 16 Contacts	25-35 128 Size 22D Contacts	25-36 3 Size 8 Contacts 1 Size 12 Coax 1 Size 12 Contact 10 Size 16 Contacts 24 Size 20 Contacts
Series	I, III, IV, EN	I, III, IV, EN	I, III, IV, EN	III, EN
Service Class	I	I	M	N
QPL	Yes	Yes	Yes	—
Class K QPL/S	—	—	Yes	—
Hermetic	Yes	Yes	Yes	—
Insert Configuration	25-37 37 Size 16 Contacts	25-43 20 Size 16 Contacts 23 Size 20 Contacts	25-46* 2 Size 8 Coax 4 Size 12 Contacts 40 Size 20 Contacts	25-47 2 Size 8 Coax 4 Size 12 Contacts 40 Size 20 Contacts
Series	I, III, IV, EN	I, III, IV, EN	I, III, IV, EN	I, III, IV
Service Class	II	I	I	I
QPL	Yes	Yes	Yes	—
Class K QPL/S	—	—	—	—
Hermetic	—	Yes	—	—
Insert Configuration	25-61 61 Size 20 Contacts	25-90* 2 Size 8 Twinax 4 Size 16 Contacts 40 Size 20 Contacts	25-91 2 Size 8 Twinax 4 Size 16 Contacts 40 Size 20 Contacts	
Series	I, III, IV, EN	I, III, IV	I, III, IV	
Service Class	I	—	I	
QPL	Yes	—	—	
Class K QPL/S	Yes	—	—	
Hermetic	Yes	—	—	

*Inactive for new designs

**RUGGED**

- Self-locking bayonet coupling system
- 100% scoop proof
- 500-mating-cycle durability
- Excellent shock and vibration resistance
- Environmentally sealed and hermetic versions available

VERSATILE

- Available in 9 shell sizes
- Intermateable and interchangeable with all other MIL-DTL-38999 Series I connectors
- Available in a variety of shell materials and finishes
- Wide range of backshells and accessories

EMI PROTECTED

- Grounding fingers for excellent EMI protection
- Connector is grounded when the shells meet, even before the contacts are engaged
- Metal-to-metal bottoming to help maximize EMI grounding protection
- EMI shielding effective up to 10 GHz

MIL-DTL-38999 Series I Connectors**DEUTSCH DJT Series Connectors**

The DEUTSCH DJT Series connectors from TE Connectivity (TE) are high-performance MIL-DTL-38999 Series I subminiature circular connectors offering a scoop-proof design for easy, reliable mating.

Available in 9 shell sizes and environmentally sealed and hermetic versions, DEUTSCH DJT Series connectors feature a self-locking bayonet coupling system. They are completely intermateable and interchangeable with MIL-DTL-38999 Series I connectors, and are available in a variety of shell materials and finishes.

Designed for rugged reliability, DEUTSCH DJT Series connectors are highly durable, capable of 500 mating cycles. They provide excellent vibration, corrosion and shock resistance, and offer excellent EMI protection and shielding effectiveness from 100 MHz to 10 GHz.



MIL-DTL-38999 Series I Connectors

DEUTSCH DJT Series Connectors

Specifications

MATERIALS

- **Shell Material and Plating:**
 - Aluminum, olive drab cadmium
 - Aluminum, electroless nickel
 - Carbon steel, electrodeposited nickel (hermetic only)
 - Stainless steel, passivated (hermetic only but can be available commercially for standard environment configurations)
- **Insert:** Thermoplastic and fluorinated silicone elastomer
- **EMI Spring Fingers:** Nickel or cadmium-plated beryllium copper
- **O-Ring:** Fluorinated silicone elastomer

ENVIRONMENTAL

- **Temperature Range:**
 - 65°C to +150°C Electrodeposited tin-plated carbon steel (Class D)
 - 65°C to +175°C - Cadmium finish (Class B)
 - 65°C to +200°C - Nickel finish (Class F) and stainless steel (Class E)
- **Fluid Resistance:** Fluid immersion per EIA 364.10, including resistance to
 - MIL-PRF-5606: Hydraulic fluid
 - MIL-DTL-83133: JP-8 aviation fuel
 - MIL-PRF-7808: Lubricating oil
 - MIL-PRF-23699: Lubricating oil
 - MIL-A-8243: Deicing/defrosting fluid
 - MIL-C-25769: Aircraft cleaning compound
 - MIL-PRF-87937: Aircraft cleaning compound
 - MIL-G-3056: Gasoline
- **Salt Spray:** 48 hours (Nickel finishes)
500 hours (Cadmium, black zinc nickel, nickel PTFE, and passivated finishes)
- **Thermal Cycling:** -65° to 150/175/200°C (max. temperature is class dependent)

MECHANICAL

- **Sine Vibration:** Up to 60 g for 36 hr.
- **Random Vibration:** Up to 41.7 g for 16 hr. at 175° C
Up to 50 g for 16 hr. at ambient temperature
- **Shock:** 300 g, 3 ms in the 3 axes
- **Durability:** 500 mating cycles
- **Contact Retention:**
 - Size 22D: 44 N (10 lb.)
 - Size 20: 67 N (15 lb.)
 - Size 16: 111 N (25 lb.)
 - Size 12: 111 N (25 lb.)
 - Size 10: 111 N (25 lb.)
 - Size 8: 111 N (25 lb.)

ELECTRICAL

- **Shell-to-Shell Conductivity:** 1.0 mV (nickel finish)
2.5 mV (cadmium finish)
10.0 mV (passivated finish)
- **Shielding Effectiveness:** >90 dB at 100 MHz, >65 dB through 10 GHz



MIL-DTL-38999 Series I Connectors

DEUTSCH DJT Series Connectors

Voltage Rating

Service Rating	Suggested Operating Voltage		Test Voltage at Altitude (VAC _{rms})			
	VAC _{rms}	VDC	Sea Level	50,000 Ft.	70,000 Ft.	100,000 Ft.
M	400	550	1300	550	350	200
N	300	450	1000	400	260	200
I	600	850	1800	600	400	200
II	750	1050	2300	800	500	200

Hermetic Connectors

- **Hermetic Seal:** Sintered glass
- **Leakage:** ≤16 cm³/hr. (0.97 in³/hr.) on mated pairs connected under 2.1 bar (4.38 psi)
- **Thermal Shock:** 10 cycles, 4°C max. to 90°C min.

Current Rating

Contact Size	Test Current (A)	Voltage Drop (mV)
22D	5	73
20	7.5	55
16	13	50
12	23	42
10	33	34
8*	46	26

*When commercial power contact replaces twin-ax contact

Thread Sizes

Shell Size	Accessory Thread (Class 2A)	Jam Nut Thread (Class 2A)
9	.4375-28 UNEF	.6875-24 UNEF
11	.5625-24 UNEF	.8125-20 UNEF
13	.6875-24 UNEF	1.0000-20 UNEF
15	.8125-20 UNEF	1.1250-18 UNEF
17	.9375-20 UNEF	1.2500-18 UNEF
19	1.0625-18 UNEF	1.3750-18 UNEF
21	1.1875-18 UNEF	1.5000-18 UNEF
23	1.3125-18 UNEF	1.6250-18 UNEF
25	1.4375-18 UNEF	1.7500-18 UNS



MIL-DTL-38999 Series I Connectors

Military Part Numbering System

MS27466 T 25 F 35 S D XXXX

MIL SPEC NUMBER/SHELL STYLE

- MS27466** Front, Wall Mount Receptacle (DJT10)
- MS27467** Straight Plug with EMI Fingers (DJT16)
- MS27468** Jam Nut Receptacle (DJT14)
- MS27470** Jam Nut Hermetic Receptacle (DJT14)
- MS27471** Solder Mount Hermetic Receptacle (DJT11)
- MS27496** Front, Box Mount Receptacle (DJT13)
- MS27505** Rear, Box Mount Receptacle (DJT12)
- MS27656** Rear, Wall Mount Receptacle (DJT19)

CLASS

- T** With Accessory Thread (MS27466, MS27467, M27468, M27656)
- E** Same As **T**, But Not Approved For New Designs (E-Nut Not Included)
- E** No Accessory Thread, Box Mount (M27496, M27505)
- G** Space-Grade Environment Resisting
- Y** Hermetically Sealed

SHELL SIZE

9, 11, 13, 15, 17, 19, 21, 23, 25

MODIFICATIONS

L/C Less Contacts

POLARIZING POSITIONS

N Normal (omit from part number)
A, B, C, D (B and C not available in shell size 9)

CONTACTS

P 500-Cycle Pin **S** 500-Cycle Socket
H 1500-Cycle Pin **J** 1500-Cycle Socket
A Less Pin (with intent to use nonstandard contacts)
B Less Socket (with intent to use nonstandard contacts)

Hermetic Contacts

P Pin, Solder Cup **S** Socket, Solder Cup
X Pin, Eyelet **Z** Socket, Eyelet
C Pin, PC Tail **D** Socket, PC Tail

INSERT ARRANGEMENT

See Insert Arrangement Tables, pages 10-17 and 22-23

FINISH

B Olive Drab Cadmium
F Nickel
G Space Grade
D Carbon Steel, Electrodeposited Tin Plating
E Stainless Steel, Passivated

DEUTSCH Part Numbering System

DJT 1 0 F 25 - 35 S D XXXX

GENERAL IDENTIFIER

DJT DEUTSCH MIL-DTL-38999 Series I

COUPLING SYSTEM

1 Bayonet

SHELL STYLE

- 0** Front, Wall Mount Receptacle (M27466)
- 6** Straight Plug with EMI Fingers (M27467)
- 4** Jam Nut Receptacle (M27468)
- 4** Jam Nut Hermetic Receptacle (MS27470)
- 1** Solder Mount Hermetic Receptacle (MS27471)
- 3** Front, Box Mount Receptacle (M27496)
- 2** Rear, Box Mount Receptacle (M27505)
- 9** Rear, Wall Mount Receptacle (M27656)

CLASS

- E** Olive Drab Cadmium
- F** Nickel
- G** Space Grade
- H** Hermetic
- Z** Black Zinc Nickel

MODIFICATIONS

6149 Less Contacts

POLARIZING POSITIONS

N Normal
A, B, C, D (B and C not available in shell size 9)

CONTACTS

P 500-Cycle Pin **S** 500-Cycle Socket
H 1500-Cycle Pin **J** 1500-Cycle Socket
A Less Pin (with intent to use nonstandard contacts)
B Less Socket (with intent to use nonstandard contacts)

Hermetic Contacts

P Pin, Solder Cup **S** Socket, Solder Cup
X Pin, Eyelet **Z** Socket, Eyelet
C Pin, PC Tail **D** Socket, PC Tail

INSERT ARRANGEMENT

See Insert Arrangement Tables, pages 10-17 and 22-23

SHELL SIZE

09, 11, 13, 15, 17, 19, 21, 23, 25



MIL-DTL-38999 Series I Connectors

DEUTSCH DJT Series Connectors

Insert		Contact Size/Quantity										QPPL	QPPL Hermetic	Uses 38999/62-8" Boots	Inactive: Superseded by
DJT and Military	8 Twinax	8 Coax	8 Power	12 Twinax	12 Coax	10	12	16	20	22D					
09-07										7					
09-35										6	✓	✓			
09-98									3		✓	✓			
11-02								2			✓	✓			
11-04									4			✓			
11-05									5		✓				
11-35										13	✓	✓			
11-98									6		✓	✓			
11-99									7		✓	✓			
13-04								4			✓	✓			
13-08									8		✓	✓			
13-35										22	✓	✓			
13-98									10		✓	✓			
15-05								5			✓				
15-15								1	14			✓			
15-18									18			✓			
15-19									19		✓	✓			
15-26								2		24					
15-35										37	✓	✓			
15-97								4	8		✓	✓			
17-02	1									38					17-03
17-03	1									38			✓		
17-06							6				✓				
17-08								8			✓				
17-11				2	1				8						
17-19								4	11	4					
17-20								4		16					
17-22	2							2							
17-24			2							22					
17-26									26		✓				
17-35										55	✓				
17-99								2	21		✓				
19-11								11			✓				
19-18	4									14					19-19
19-19	4									14			✓		
19-28								2	26						
19-32									32		✓				

Blue shaded entries are not Mil Spec.



MIL-DTL-38999 Series I Connectors

DEUTSCH DJT Series Connectors

Insert	Contact Size/Quantity										QPL	QPL Hermetic	Uses 38999/62-8" Boots	Inactive: Superseded by	
	DJT and Military	8 Twinax	8 Coax	8 Power	12 Twinax	12 Coax	10	12	16	20					22D
19-35											66	✓			
21-11							11					✓			
21-16								16				✓			
21-20	2								18						
21-35										79		✓			
21-39								2	37			✓			
21-41									41			✓			
21-48			4												
21-75	4														21-76
21-76	4												✓		
23-06	6														
23-21								21				✓			
23-35										100		✓			
23-53									53			✓			
23-54							4	9		40					
23-55									55			✓			
23-63							4	4		49					
25-04								8	48			✓	✓		
25-07	2									97					25-09
25-08	8														25-10
25-09	2									97				✓	
25-10	8													✓	
25-17	6									36					
25-19							19					✓	✓		
25-20	3				4			13	10						25-21
25-21	3				4			13	10					✓	
25-24							12	12				✓	✓		
25-29								29				✓	✓		
25-35										128		✓	✓		
25-37								37				✓	✓		
25-43								20	23			✓	✓		
25-46		2						4	40						25-47
25-47		2						4	40					✓	
25-61									61			✓	✓		
25-90	2							4	40						25-91
25-91	2							4	40					✓	

Blue shaded entries are not Mil Spec.



MIL-DTL-38999 Series I Connectors

DEUTSCH DJT Series Connectors

Front Panel Mount Square Flange Receptacle

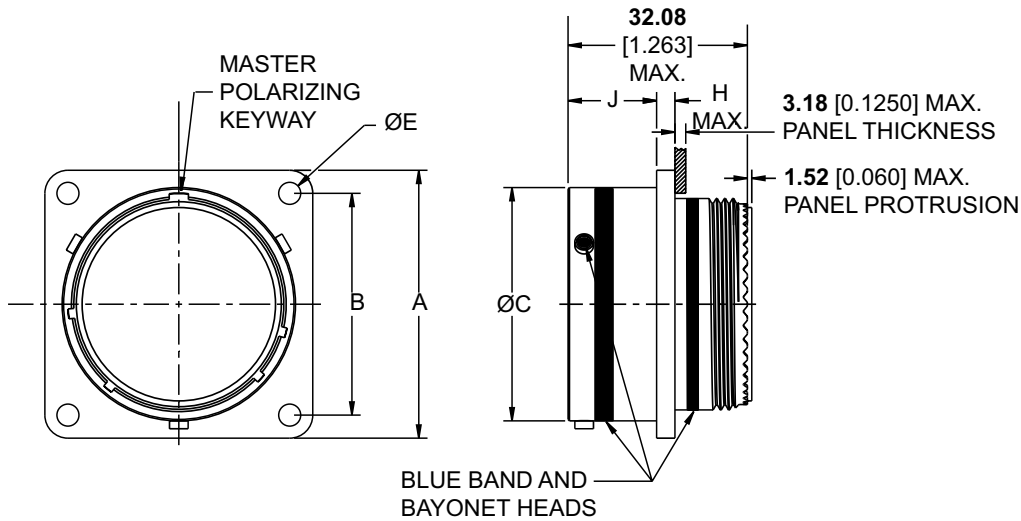

Shell Size	A ±0.51 (0.020)	B ±0.13 (0.005)	C ±0.08 (0.003)	E +0.25 ± 0.25/-0.13 (+0.010/-0.005)	F	G ±0.13 (0.005)	H	J +0.00 / -0.13 (0.005)
09	23.83 0.938	18.26 0.719	14.48 0.570	3.25 0.128	13.11 0.516	3.25 0.128	2.54 0.100	16.05 0.623
11	26.19 1.031	20.62 0.812	17.73 0.698	3.25 0.128	16.87 0.664	3.25 0.128	2.54 0.100	16.05 0.623
13	28.58 1.125	23.01 0.906	21.54 0.848	3.25 0.128	19.05 0.750	3.25 0.128	2.54 0.100	16.05 0.623
15	30.96 1.219	24.61 0.969	24.71 0.973	3.25 0.128	23.01 0.906	3.25 0.128	2.54 0.100	16.05 0.623
17	33.32 1.312	26.97 1.062	27.89 1.098	3.25 0.128	25.81 1.016	3.25 0.128	2.54 0.100	16.05 0.623
19	36.53 1.438	29.36 1.156	30.61 1.205	3.25 0.128	28.98 1.141	3.25 0.128	2.54 0.100	16.05 0.623
21	39.67 1.562	31.75 1.250	33.78 1.330	3.25 0.128	32.16 1.266	3.25 0.128	3.30 0.130	15.29 0.602
23	42.88 1.688	34.93 1.375	36.96 1.455	3.73 0.147	34.98 1.377	3.91 0.154	3.30 0.130	15.29 0.602
25	46.02 1.812	38.10 1.500	40.13 1.580	3.73 0.147	37.69 1.484	3.91 0.154	3.30 0.130	15.29 0.602

Millimeters Inches



MIL-DTL-38999 Series I Connectors

DEUTSCH DJT Series Connectors

Jam Nut Receptacle

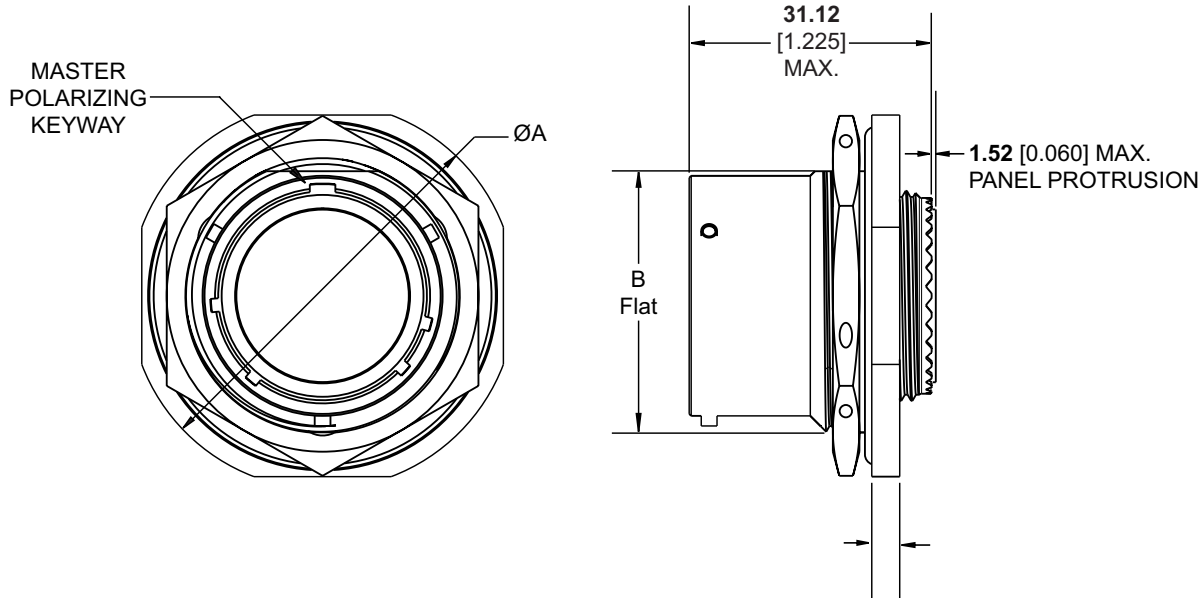

Shell Size	ØA ±0.41 (0.016)	B Flat +0.00 / -0.25 (0.010)	F +0.00 / -0.25 (0.010)	ØG +0.00 / -0.25 (0.010)
09	30.18 1.188	16.64 0.655	17.02 0.670	17.78 0.700
11	34.93 1.375	19.18 0.755	19.58 0.771	20.96 0.825
13	38.10 1.500	23.93 0.942	24.26 0.955	25.65 1.010
15	41.28 1.625	27.08 1.066	27.56 1.085	28.83 1.135
17	44.45 1.750	30.25 1.191	30.73 1.210	32.00 1.260
19	49.23 1.938	33.43 1.316	33.91 1.335	35.18 1.385
21	52.37 2.062	36.60 1.441	37.08 1.460	38.35 1.510
23	55.58 2.188	39.78 1.566	40.26 1.585	41.53 1.635
25	58.72 2.312	42.95 1.691	43.43 1.710	44.70 1.760

Millimeters Inches



MIL-DTL-38999 Series I Connectors

DEUTSCH DJT Series Connectors

Rear Panel Wall Mount Square Flange Receptacle

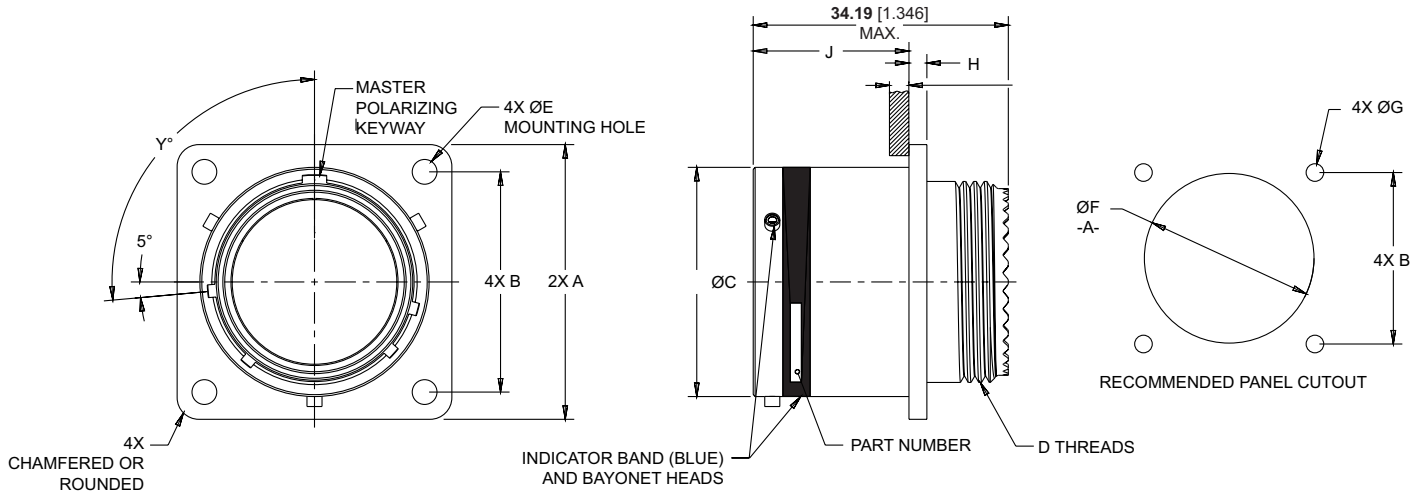

Shell Size	A ±0.51 (0.020)	B ±0.13 (0.005)	C ±0.08 (0.003)	D THREAD UNE-F-2A	ØE +0.25 -0.13 (+0.010 -0.005)	ØF Min.	ØG ±0.13 (0.005)	H +0.38 -0.00 (+0.015 -0.000)	J +0.00 -0.13 (+0.000 -0.005)
09	23.83 0.938	18.26 0.719	14.48 0.570	11.11-28 0.4375-28	3.25 0.128	13.11 0.516	3.25 0.128	2.16 0.085	20.83 0.820
11	26.19 1.031	20.62 0.812	17.73 0.698	14.29-24 0.5625-24	3.25 0.128	16.87 0.664	3.25 0.128	2.16 0.085	20.83 0.820
13	28.58 1.125	23.01 0.906	21.54 0.848	17.46-24 0.6875-24	3.25 0.128	19.05 0.750	3.25 0.128	2.16 0.085	20.83 0.820
15	30.96 1.219	24.61 0.969	24.71 0.973	20.64-20 0.8125-20	3.25 0.128	23.01 0.906	3.25 0.128	2.16 0.085	20.83 0.820
17	33.32 1.312	26.97 1.062	27.89 1.098	23.81-20 0.9375-20	3.25 0.128	25.81 1.016	3.25 0.128	2.16 0.085	20.83 0.820
19	36.53 1.438	29.36 1.156	30.61 1.205	26.99-18 1.0625-18	3.25 0.128	28.98 1.141	3.25 0.128	2.16 0.085	20.83 0.820
21	39.67 1.562	31.75 1.250	33.78 1.330	30.16-18 1.1875-18	3.25 0.128	32.16 1.266	3.25 0.128	2.92 0.115	20.07 0.790
23	42.88 1.688	34.93 1.375	36.96 1.455	33.34-18 1.3125-18	3.73 0.147	34.98 1.377	3.91 0.154	2.92 0.115	20.07 0.790
25	46.02 1.812	38.10 1.500	40.13 1.580	36.51-18 1.4375-18	3.73 0.147	37.69 1.484	3.81 0.150	2.92 0.115	20.07 0.790

Millimeters Inches



MIL-DTL-38999 Series I Connectors

DEUTSCH DJT Series Connectors

Plug
Type MS27467 / DEUTSCH DJT16

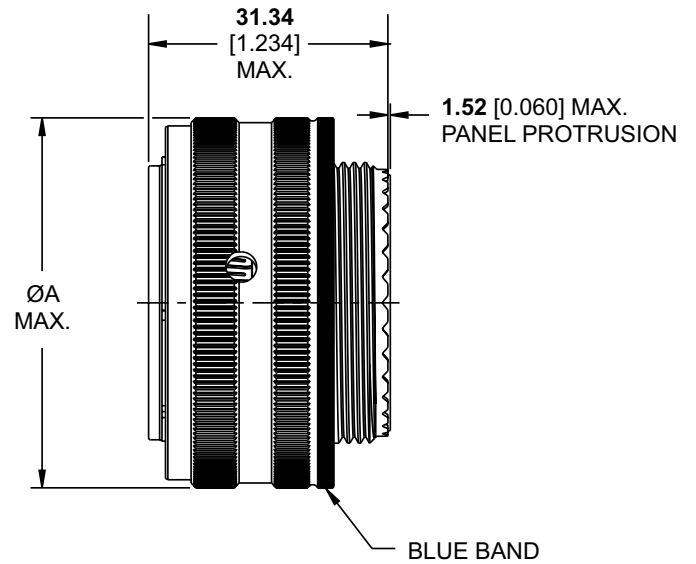
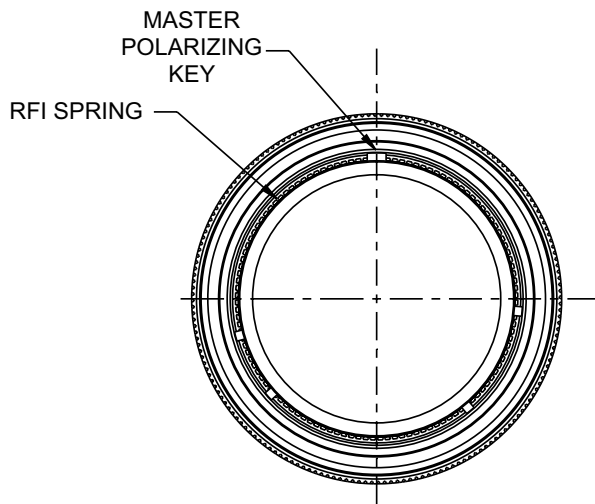

Shell Size	A
09	21.82 .859
11	24.99 .984
13	29.36 1.156
15	32.54 1.281
17	35.71 1.406
19	38.51 1.516
21	41.68 1.641
23	44.86 1.766
25	48.03 1.891

Millimeters Inches



MIL-DTL-38999 Series I Connectors

DEUTSCH DJT Series Connectors

Recommended Panel Cutouts

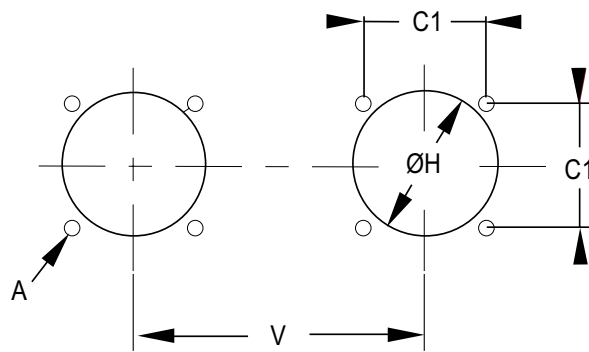

Square Flange Receptacle

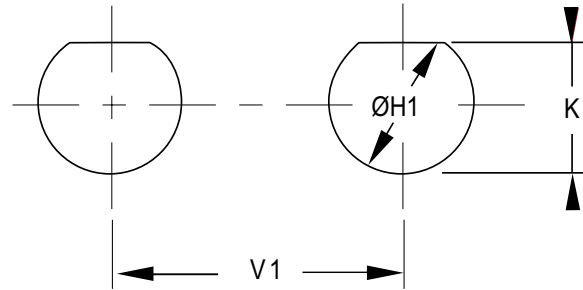

Jam Nut Receptacle

Shell Size	C1 ±0.13 (0.005)	H Min.	A ±0.13 (0.005)	V Min.
09	18.26 0.719	13.11 0.516	3.25 0.128	25.58 1.007
11	20.62 0.812	16.87 0.664	3.25 0.128	27.00 1.063
13	23.01 0.906	19.05 0.750	3.25 0.128	30.20 1.189
15	24.61 0.969	23.01 0.906	3.25 0.128	33.30 1.331
17	26.97 1.062	25.81 1.016	3.25 0.128	36.50 1.437
19	29.36 1.156	28.98 1.141	3.25 0.128	39.30 1.547
21	31.75 1.250	32.16 1.266	3.25 0.128	42.50 1.673
23	34.93 1.375	34.98 1.377	3.91 0.154	45.70 1.799
25	38.10 1.500	37.69 1.484	3.91 0.154	48.80 1.921

Millimeters Inches

Shell Size	K +0.00 / -0.25 (0.010)	ØH1 +0.00 / -0.25 (0.010)	V1 Min.
09	17.02 0.670	17.78 0.700	20.20 1.189
11	19.58 0.771	20.96 0.825	32.60 1.283
13	24.26 0.955	25.65 1.010	36.00 1.417
15	27.56 1.085	28.83 1.135	39.60 1.559
17	30.73 1.210	32.00 1.260	43.30 1.705
19	33.91 1.335	35.18 1.385	47.00 1.850
21	37.08 1.460	38.35 1.510	50.60 1.992
23	40.26 1.585	41.53 1.635	54.20 2.134
25	43.43 1.710	44.70 1.760	59.70 2.350

Millimeters Inches



MIL-DTL-38999 Series I Connectors

DEUTSCH DJT Series Connectors

Keying Options

(Viewed from Mating Face of the Receptacle Connector)

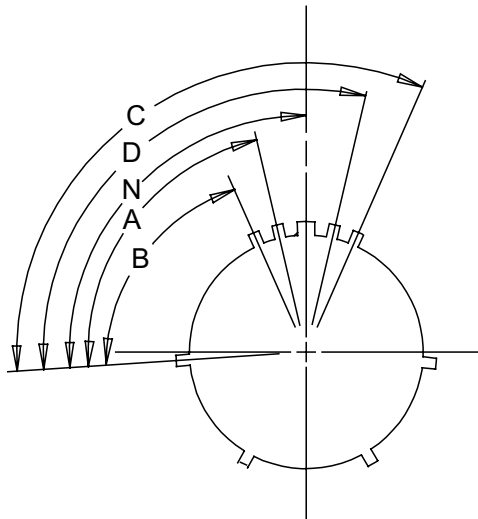

Shell Size	Key Position (Degrees)				
	N	A	B	C	D
09	95	77	—	—	113
11	95	81	67	123	109
13	95	75	63	127	115
15	95	74	61	129	116
17	95	77	65	125	113
19	95	77	65	125	113
21	95	77	65	125	113
23	95	80	69	121	110
25	95	80	69	121	110

Degrees in table above are the distance between Datum E (that bisects first minor keyway) and the center line of the master keyway



RELIABLE

- Self-locking threaded coupling
- 100% scoop proof
- Contact retention system provides excellent contact retention under severe vibration

EMI PROTECTED

- Grounding fingers for excellent EMI protection
- Metal-to-metal bottoming for maximum EMI grounding protection
- Connector is grounded when the shells meet, even before the contacts are engaged
- Trapezoidal thread for excellent shell-to-shell continuity

VERSATILE

- Variety of shell materials and finishes
- Wide range of backshells and accessories

MIL-DTL-38999 Series III Connectors



DEUTSCH DTS Series Aluminum Connectors
DEUTSCH DTS-K, DTS-L and DTS-S Series
Stainless Steel Connectors
DEUTSCH ACT Series Composite Connectors

DEUTSCH MIL-DTL-38999 Series subminiature circular connectors offer a scoop-proof design for easy, reliable mating and a threaded coupling for excellent vibration resistance. They are available in three families distinguished by shell materials.

DTS Series: Lightweight aluminum shells for environmentally sealed versions and stainless steel for hermetic versions.

DTS-K and DTS-S Series: Stainless steel shells meeting the requirements of Classes K and S, suitable for firewall and high-temperature applications such as engines.

ACT Series: Composite shells, offering the lightest weight and highest resistance to corrosion.

Inserts are available in nine shell sizes, with contact arrangements meeting MIL-DTL-1560, along with additional arrangements, to help maximize flexibility in circuit configurations.

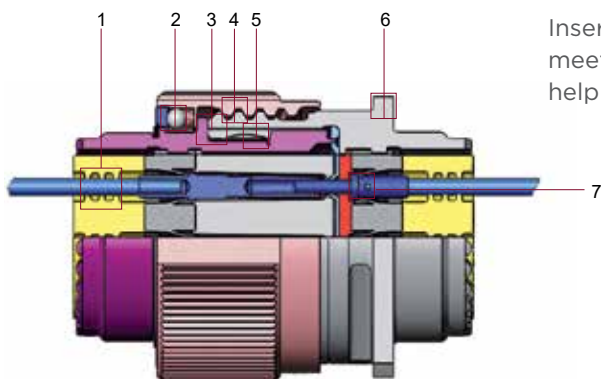

Designed to Perform

- 1** High-quality silicone seals to help maximize tear resistance and sealing memory
- 2** Self-locking threaded coupling
- 3** 100% metal-to-metal bottoming for excellent EMI grounding protection
- 4** Triple-start threads
- 5** Grounding fingers providing excellent EMI protection
- 6** Elongated mounting holes for flexible mounting with standard MIL-DTL-38999 box or wall mount receptacles
- 7** Contact retention system provides excellent contact retention under severe vibration



MIL-DTL-38999 Series III Connectors

DEUTSCH DTS and ACT Series Connectors

Specifications

MATERIALS

- **Shell:** Aluminum, composite, stainless steel, marine bronze
- **Plating:** Olive drab cadmium, passivated, electroless or electrodeposited nickel, nickel PTFE, black zinc nickel
- **Insert:** Thermoplastic and fluorinated silicone elastomer
- **EMI Spring Fingers:** Nickel or cadmium-plated beryllium copper
- **O-Ring:** Fluorinated silicone elastomer

ENVIRONMENTAL

- **Temperature Range:**
-65°C to +200°C
- **Fluid Resistance:** Fluid immersion per EIA 364.10, including resistance to
MIL-PRF-5606: Hydraulic fluid
MIL-DTL-83133: JP-8 aviation fuel
MIL-PRF-7808: Lubricating oil
MIL-PRF-23699: Lubricating oil
MIL-A-8243: Deicing/defrosting fluid
MIL-C-25769: Aircraft cleaning compound
MIL-PRF-87937: Aircraft cleaning compound
MIL-G-3056: Gasoline
- **Salt Spray:** 48 hours (Nickel finishes)
500 hours (Cadmium, black zinc nickel, nickel PTFE, and passivated finishes)
2000 hours (Composite classes M and J)
- **Thermal Cycling:** -65° to 150/175/200°C (max. temperature is class dependent)

MECHANICAL

- **Sine Vibration:** Up to 60 g for 36 hr.
- **Random Vibration:** Up to 41.7 g for 16 hr. at 175° C
Up to 50 g for 16 hr. at ambient temperature
- **Shock:** 300 g, 3 ms in the 3 axes
- **Durability:** 500 mating cycles (1500 cycles for composite connectors)
- **Contact Retention:**
Size 23: 44 N (10 lb.)
Size 22D: 44 N (10 lb.)
Size 20: 67 N (15 lb.)
Size 16: 111 N (25 lb.)
Size 12: 111 N (25 lb.)
Size 10: 111 N (25 lb.)
Size 8: 111 N (25 lb.)

ELECTRICAL

- **Shell-to-Shell Conductivity:**
1.0 mV (nickel finish)
2.5 mV (cadmium finish)
3 mV (passivated finish)
- **Shielding Effectiveness:** >90 dB at 100 MHz, >65 dB through 10 GHz



MIL-DTL-38999 Series III Connectors

DEUTSCH DTS and ACT Series Connectors

Voltage Rating

Service Rating	Suggested Operating Voltage		Test Voltage at Altitude (VAC _{rms})			
	VAC _{rms}	VDC	Sea Level	50,000 Ft.	70,000 Ft.	100,000 Ft.
M	400	550	1300	550	350	200
N	300	450	1000	400	260	200
I	600	850	1800	600	400	200
II	750	1050	2300	800	500	200

Hermetic Connectors

- **Hermetic Seal:** Sintered glass
- **Leakage:** ≤16 cm³/hr. (0.97 in³/hr.) on mated pairs connected under 2.1 bar (4.38 psi)
- **Thermal Shock:** 10 cycles, 4°C max. to 90°C min.

Current Rating

Contact Size	Test Current (A)	Voltage Drop (mV)
23	3	73
22D	5	73
20	7.5	55
16	13	50
12	23	42
10	33	34
8*	46	26

*When commercial power contact replaces twin-ax contact

Thread Sizes

Shell Size	Accessory Thread (6g 0.100R)	Mating Thread (0.1P-0.3L)	Jam Nut Thread (6g 0.100R)
9	M12 x 1.0	.6250	M17 x 1.0
11	M15 x 1.0	.7500	M20 x 1.0
13	M18 x 1.0	.8750	M25 x 1.0
15	M22 x 1.0	1.0000	M28 x 1.0
17	M25 x 1.0	1.1875	M32 x 1.0
19	M28 x 1.0	1.2500	M35 x 1.0
21	M31 x 1.0	1.3750	M38 x 1.0
23	M34 x 1.0	1.5000	M41 x 1.0
25	M37 x 1.0	1.6250	M44 x 1.0



MIL-DTL-38999 Series III Connectors
DEUTSCH DTS and ACT Series Connectors

Part Numbering MIL-DTL-38999
and DEUTSCH Commerical Versions

		Commercial Composite	ACT	26	M	D	35	P	N	-6149
		Commercial Al/SS	DTS	26	F	15	- 35	P	N	-6149
		Military	D38999	/26	F	D	35	P	N	-L/C
Commercial Composite	Commercial Alum./Stainless	Military	Description							
RANGE										
ACT	DTS	D38999								
STYLE										
20	20	/20	Square Flange Receptacle							
24	24	/24	Jam Nut Receptacle							
26	26	/26	Straight Plug							
-	13	-	Box Mount Receptacle							
-	20	/21	Hermetic Square Flange Receptacle							
-	24	/23	Hermetic Jam Nut Receptacle							
-	21	/25	Hermetic Solder Flange							
-	23	/27	Hermetic Weld Flange							
CLASS										
ALUMINUM SHELL										
-	F	F	Electroless Nickel Plated (48-hr. Salt Spray)							
-	G	G	Space-Grade Electroless Nickel (48-hr. Salt Spray)							
-	T	T	Nickel PTFE (500-hr. Salt Spray)							
-	W	W	Olive Drab Cadmium (500-hr. Salt Spray)							
-	Z	Z	Black Zinc Nickel (500-hr. Salt Spray)							
COMPOSITE SHELL										
M	-	M	Electroless Nickel Plated (2000-hr. Salt Spray)							
J	-	J	Olive Drab Cadmium (2000-hr. Salt Spray)							
STAINLESS STEEL SHELL										
-	K	K	Passivated S.S., Firewall (500-hr. Salt Spray)							
-	S	S	Electrodeposited Nickel S.S., Firewall (500-hr. Salt Spray)							
-	L	L	Electrodeposited Nickel (48-hr. Salt Spray)							
HERMETIC										
-	Y	Y	Stainless Steel, Passivated							
-	N	N	Stainless Steel, Electrodeposited Nickel Plated							
-	H	H	Space Grade							
SHELL SIZES										
9 (A), 11 (B), 13 (C), 15 (D), 17 (E), 19 (F), 21 (G), 23 (H), 25 (J)			Numbers = DTS Commercial; (Letters) = Military/ACT Commercial							
INSERT ARRANGEMENTS										
			See Insert Arrangement Tables, pages 10-17 and 35-36							
CONTACTS										
P	Pin,	H	1500-Cycle Pin							
S	Socket,	J	1500-Cycle Socket							
A	Less Pin (with intent to use nonstandard contacts)									
B	Less Socket (with intent to use nonstandard contacts)									
CONTACTS FOR HERMETIC CONNECTORS										
P	Pin, Solder Cup,	S	Socket, Solder Cup							
C	PC Tail Pin,	D	PC Tail Socket							
X	Eyelet Pin,	Z	Eyelet Socket							
KEYING										
N, A, B, C, D, E, U			N = Normal, U = Universal							
MODIFICATION CODE										
6149	6149	L/C	Less Contacts							



MIL-DTL-38999 Series III Connectors

DEUTSCH DTS and ACT Series Connectors

Part Numbering

EN3645 and DEUTSCH Commercial Versions

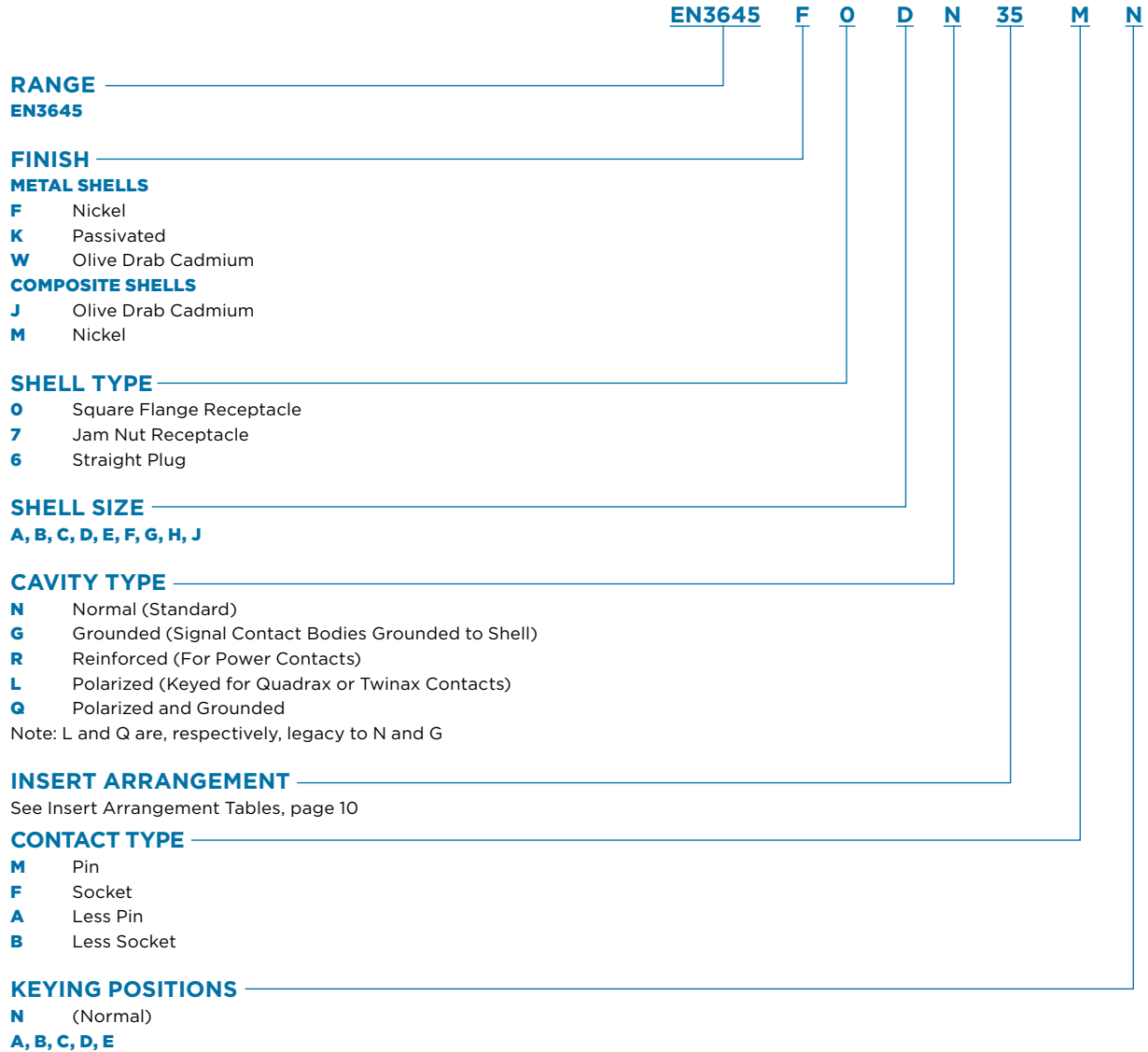



MIL-DTL-38999 Series III Connectors

DEUTSCH DTS and ACT Series Connectors

Insert		Contact Size/Quantity											Includes K Class	Uses 38999/62-8" Boots	Inactive: Superseded by
DTS Commercial	Military (Commercial ACT)	8 Twinx	8 Coax	8 Power	12 Twinx	12 Coax	10	12	16	20	22D	23			
09-07	A7 (A07)										7				
09-23	A23											9			
09-35	A35										6		✓		
09-98	A98									3			✓		
11-02	B2 (B02)							2							
11-04	B4 (B04)								4						
11-05	B5 (B05)								5						
11-23	B23											19			
11-35	B35										13		✓		
11-98	B98									6			✓		
11-99	B99									7			✓		
13-04	C4 (C04)							4							
13-08	C8 (C08)								8				✓		
13-23	C23											32			
13-35	C35										22		✓		
13-98	C98								10				✓		
15-05	D5 (D05)							5					✓		
15-15	D15							1	14						
15-18	D18									18			✓		
15-19	D19									19			✓		
15-23	D23											55			
15-26	D26							2		24					
15-35	D35									37			✓		
15-97	D97							4	8				✓		
17-02	E2 (E02)	1									38				17-03
17-03	E3 (E03)	1									38			✓	
17-06	E6 (E06)							6					✓		
17-08	E8 (E08)								8				✓		
17-11	E11				2	1				8					
17-19	E19								4	11	4				
17-20	E20								4		16				
17-22	E22	2						2							
17-23	E23											73			
17-24	E24			2							22				
17-26	E26									26			✓		
17-35	E35										55		✓		
17-99	E99							2	21				✓		
19-11	F11							11					✓		
19-18	F18	4									14				19-19
19-19	F19	4									14			✓	
19-23	E23											88			
19-28	F28							2	26						

Blue shaded entries are not Mil Spec. Green shading indicates high-density inserts.



MIL-DTL-38999 Series III Connectors

DEUTSCH DTS and ACT Series Connectors

Insert		Contact Size/Quantity											Includes K Class	Uses 38999/62-8* Boots	Inactive: Superseded by
DTS Commercial	Military (Commercial ACT)	8 Twinx	8 Coax	8 Power	12 Twinx	12 Coax	10	12	16	20	22D	23			
19-32	F32									32			✓		
19-35	F35										66		✓		
21-11	G11							11							
21-16	G16								16						
21-20	G20	2								18					
21-23	G23											121			
21-35	G35										79		✓		
21-39	G39								2	37			✓		
21-41	G41									41			✓		
21-48	G48			4											
21-75	G75	4													21-76
21-76	G76	4												✓	
23-06	H6 (H06)	6													
23-21	H21								21						
23-23	H23												151		
23-35	H35										100				
23-53	H53									53			✓		
23-54	H54							4	9		40				
23-55	H55									55					
23-63	H63							4	4		49				
25-04	J4 (J04)								8	48			✓		
25-07	J7 (J07)	2									97				25-09
25-08	J8 (J08)	8													25-10
25-09	J9 (J09)	2									97			✓	
25-10	J10	8												✓	
25-11	J11						9			2					
25-17	J17	6									36				
25-19	J19								19						
25-20	J20	3				4			13	10					25-21
25-21	J21	3				4			13	10				✓	
25-23	J23												187		
25-24	J24								12	12					
25-29	J29									29					
25-35	J35										128		✓		
25-37	J37									37					
25-43	J43								20	23					
25-46	J46		2						4	40					25-47
25-47	J47		2						4	40				✓	
25-61	J61									61			✓		
25-90	J90	2							4	40					25-91
25-91	J91	2							4	40				✓	

Blue shaded entries are not Mil Spec.
Green shading indicates high-density inserts.



MIL-DTL-38999 Series III Connectors

DEUTSCH DTS and ACT Series Connectors

Square Flange Receptacle
Type 20

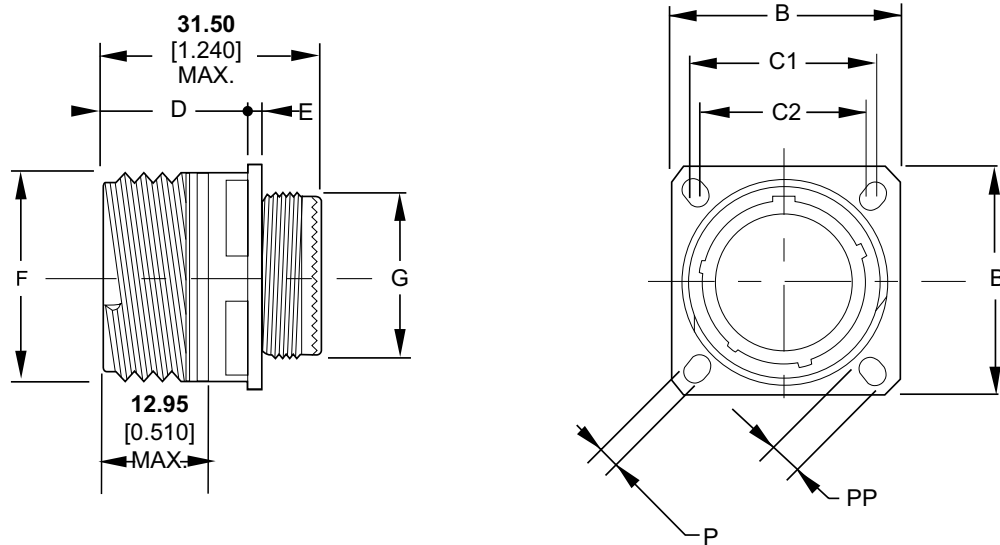

Shell Size	B	C1	C2	D Max.	E Max.	F	G	P	PP	Mass (g) by Shell Type		
										Al	SS	Composite
09	23.80 0.937	18.26 0.719	15.09 0.594	20.90 0.823	2.50 0.098	15.75 0.620	11.90 0.469	3.25 0.128	5.49 0.216	10	27	9
11	26.20 1.031	20.62 0.812	18.26 0.719	20.90 0.823	2.50 0.098	18.90 0.744	14.90 0.587	3.25 0.128	4.93 0.194	16	36	11
13	28.60 1.126	23.01 0.906	20.62 0.812	20.90 0.823	2.50 0.098	22.10 0.870	17.90 0.705	3.25 0.128	4.93 0.194	19	45	14
15	31.00 1.220	24.61 0.969	23.01 0.906	20.90 0.823	2.50 0.098	25.25 0.994	21.90 0.862	3.25 0.128	4.93 0.194	25	56	18
17	33.30 1.311	26.97 1.062	24.61 0.969	20.90 0.823	2.50 0.098	29.95 1.179	24.90 0.980	3.25 0.128	4.93 0.194	32	74	23
19	36.50 1.437	29.36 1.156	26.97 1.062	20.90 0.823	2.50 0.098	31.55 1.242	27.90 1.098	3.25 0.128	4.93 0.194	39	78	26
21	39.70 1.563	31.75 1.250	29.36 1.156	20.10 0.791	3.20 0.126	34.70 1.366	30.90 1.217	3.25 0.128	4.93 0.194	45	95	31
23	42.90 1.689	34.93 1.375	31.75 1.250	20.10 0.791	3.20 0.126	37.90 1.492	33.90 1.335	3.91 0.154	6.15 0.242	54	108	36
25	46.00 1.811	38.10 1.500	34.93 1.375	20.10 0.791	3.20 0.126	41.10 1.618	36.90 1.453	3.91 0.154	6.15 0.242	59	120	43

Millimeters Inches



MIL-DTL-38999 Series III Connectors

DEUTSCH DTS and ACT Series Connectors

Jam Nut Receptacle
Type 24

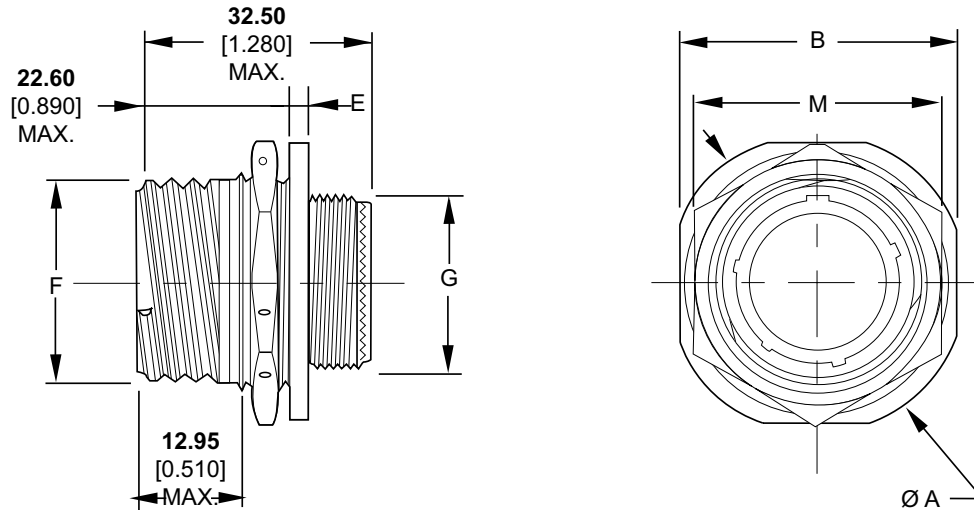

Shell Size	A	B	E	F	G	M Max.	Mass (g) by Shell Type		
							Al	SS	Composite
09	30.20 1.189	27.00 1.063	2.20 0.087	15.75 0.620	11.90 0.469	24.00 0.945	15	40	11
11	34.90 1.374	31.80 1.252	2.20 0.087	18.90 0.744	14.90 0.587	27.00 1.063	21	50	14
13	38.10 1.500	34.90 1.374	2.20 0.087	22.10 0.870	17.90 0.705	32.00 1.260	27	60	18
15	41.30 1.626	38.10 1.500	2.20 0.087	25.25 0.994	21.90 0.862	36.00 1.417	32	72	23
17	44.50 1.752	41.30 1.626	2.20 0.087	29.95 1.179	24.90 0.980	37.00 1.457	40	92	29
19	49.20 1.937	46.00 1.811	3.00 0.118	31.55 1.242	27.90 1.098	41.00 1.614	49	96	35
21	52.40 2.063	49.20 1.937	3.00 0.118	34.70 1.366	30.90 1.217	46.00 1.811	54	114	38
23	55.60 2.189	52.40 2.063	3.00 0.118	37.90 1.492	33.90 1.335	50.00 1.969	65	130	46
25	58.70 2.311	55.60 2.189	3.00 0.118	41.10 1.618	36.90 1.453	51.23 2.017	73	143	55

Millimeters Inches



MIL-DTL-38999 Series III Connectors

DEUTSCH DTS and ACT Series Connectors

Plug Type 26

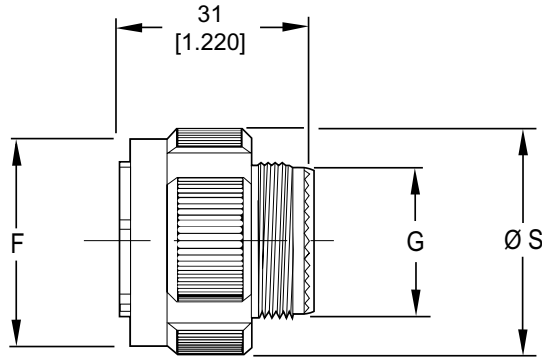

Shell Size	F Max.	G	S Max.	Mass (g) by Shell Type		
				Al	SS	Composite
09	18.40 0.724	11.90 0.469	21.80 0.858	15	36	9
11	21.10 0.831	14.90 0.587	25.00 0.984	20	50	13
13	25.40 1.000	17.90 0.705	29.40 1.157	27	64	18
15	28.70 1.130	21.90 0.862	32.50 1.280	34	80	23
17	32.20 1.268	24.90 0.980	35.70 1.406	37	88	25
19	34.90 1.374	27.90 1.098	38.50 1.516	48	102	32
21	38.10 1.500	30.90 1.217	41.70 1.642	55	117	35
23	41.10 1.618	33.90 1.335	44.90 1.768	67	131	41
25	44.30 1.744	36.90 1.453	48.00 1.890	71	145	48

Millimeters Inches

Coupling Torque: Plug to Receptacle

Shell Size	Engagement and Disengagement (Max.)		Minimum Disengagement	
	Nm	Lb.-in.	Nm	Lb.-in.
09	0.9	8		
11	1.4	12	0.2	2
13	1.8	16		
15	2.3	20		
17	2.7	24	0.3	3
19	3.2	28		
21	3.6	32		
23	4.1	36	0.6	5
25	4.6	40		



MIL-DTL-38999 Series III Connectors

DEUTSCH DTS and ACT Series Connectors

Mated/Unmated Dimensions

Square Flange Receptacle to Plug

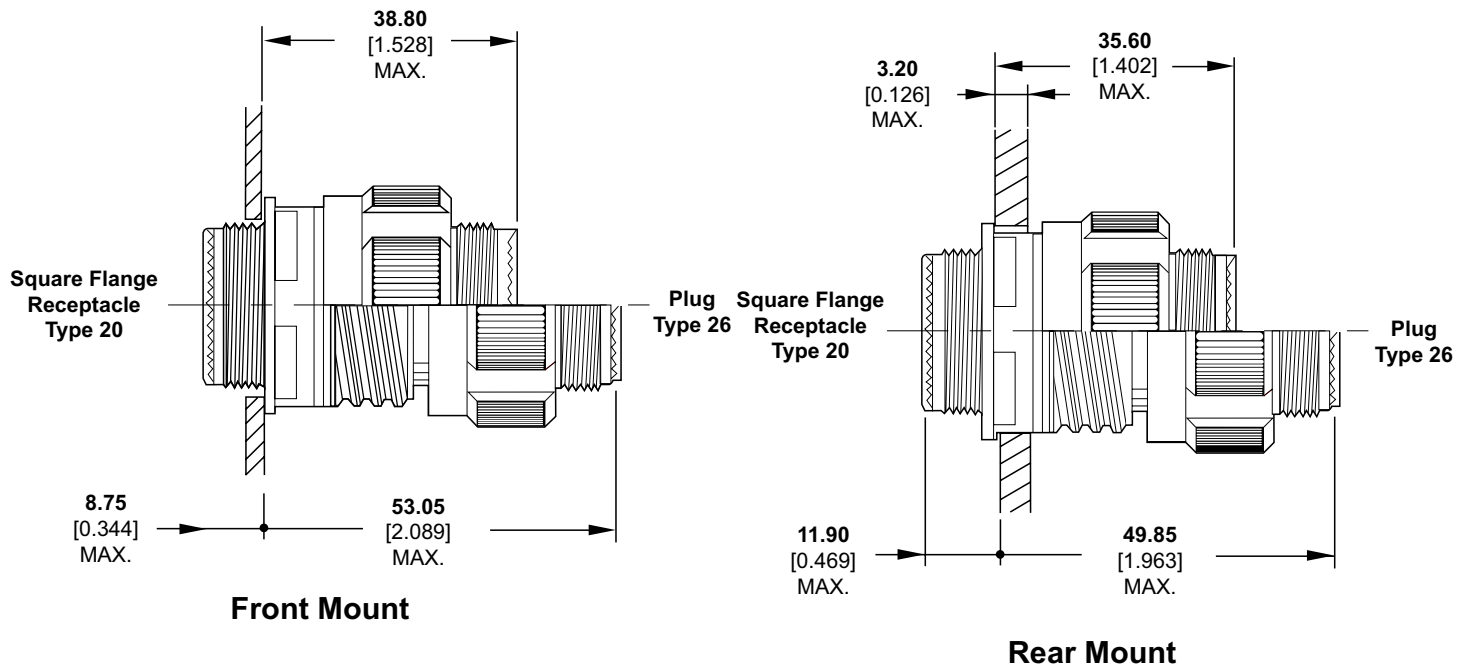

Jam Nut Receptacle to Plug

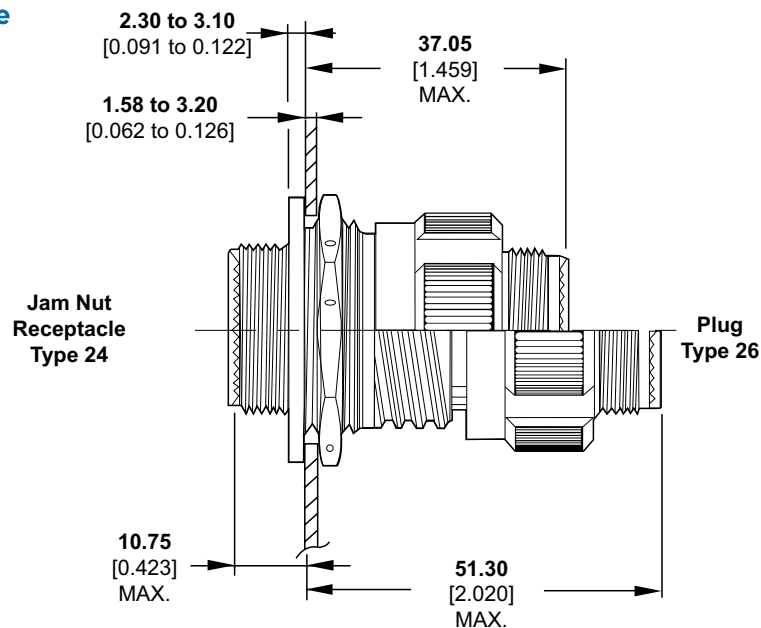



MIL-DTL-38999 Series III Connectors

DEUTSCH DTS and ACT Series Connectors

Dummy Receptacle
Type PR

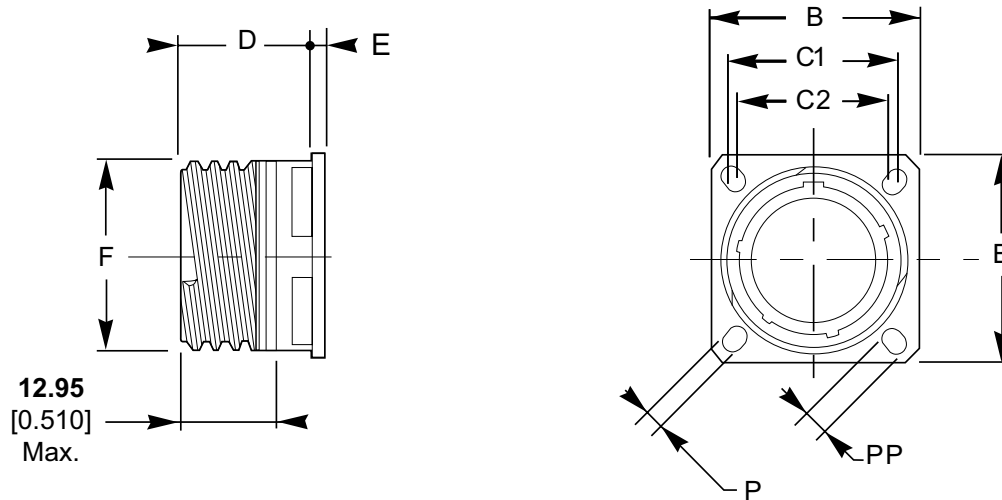

Shell Size	B	C1	C2	D Max.	E Max.	F	G	P	PP	Mass (g) by Shell Type		
										Al	SS	Composite
09	23.80 0.937	18.26 0.719	15.09 0.594	20.90 0.823	2.50 0.098	15.73 0.619	3.25 0.128	5.49 0.216	5.49 0.216	7	10	8
11	26.20 1.031	20.62 0.812	18.26 0.719	20.90 0.823	2.50 0.098	18.91 0.744	3.25 0.128	4.93 0.194	4.93 0.194	11	16	11
13	28.60 1.126	23.01 0.906	20.62 0.812	20.90 0.823	2.50 0.098	22.08 0.869	3.25 0.128	4.93 0.194	4.93 0.194	15	22	14
15	31.00 1.220	24.61 0.969	23.01 0.906	20.90 0.823	2.50 0.098	25.26 0.994	3.25 0.128	4.93 0.194	4.93 0.194	18	31	18
17	33.30 1.311	26.97 1.062	24.61 0.969	20.90 0.823	2.50 0.098	29.96 1.180	3.25 0.128	4.93 0.194	4.93 0.194	22	46	23
19	36.50 1.437	29.36 1.156	26.97 1.062	20.90 0.823	2.50 0.098	31.54 1.242	3.25 0.128	4.93 0.194	4.93 0.194	26	51	26
21	39.70 1.563	31.75 1.250	29.36 1.156	20.10 0.791	3.20 0.126	34.72 1.367	3.25 0.128	4.93 0.194	4.93 0.194	30	65	31
23	42.90 1.689	34.93 1.375	31.75 1.250	20.10 0.791	3.20 0.126	37.90 1.492	3.91 0.154	6.15 0.242	6.15 0.242	33	78	36
25	46.00 1.811	38.10 1.500	34.93 1.375	20.10 0.791	3.20 0.126	41.07 1.617	36.90 1.453	3.91 0.154	6.15 0.242	36	97	43

Millimeters Inches



MIL-DTL-38999 Series III Connectors

DEUTSCH DTS and ACT Series Connectors

Recommended Panel Cutouts

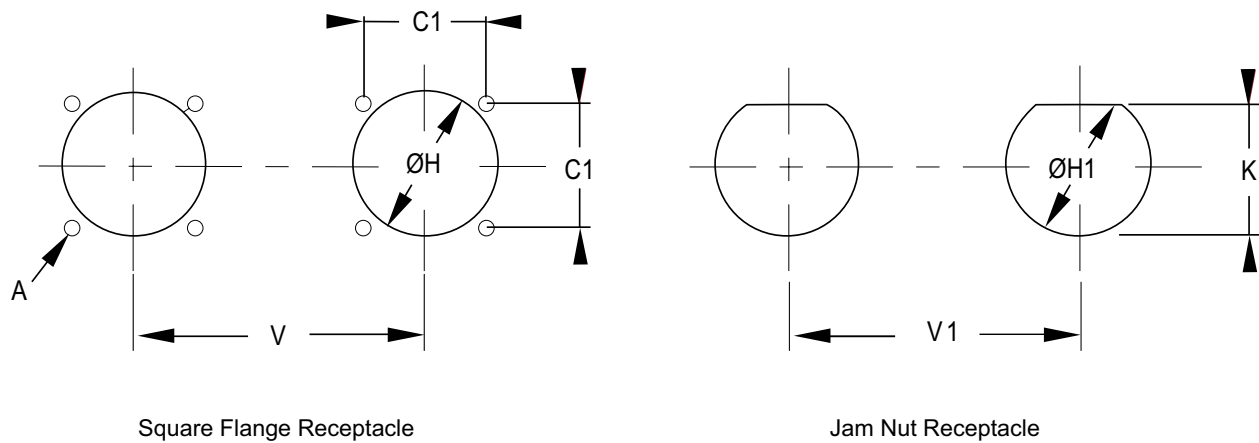

Shell Size	A	C1	H Min.		H1 Max.	K Max.	V Min.	V1 Min.
			Front	Rear				
9		18.26 0.719	13.11 0.516	16.66 0.656	17.78 0.700	16.70 0.657	25.58 1.007	20.20 1.189
11		20.62 0.812	15.08 0.594	22.22 0.875	20.88 0.822	19.53 0.769	27.00 1.063	32.60 1.283
13		23.01 0.906	19.05 0.750	23.42 0.922	25.58 1.007	24.26 0.995	30.20 1.189	36.00 1.417
15	3.25 0.128	24.61 0.969	23.01 0.906	26.59 1.047	28.80 1.134	27.53 1.084	33.30 1.331	39.60 1.559
17		26.97 1.062	25.81 1.106	30.96 1.219	31.98 1.259	30.68 1.208	36.50 1.437	43.30 1.705
19		29.36 1.156	28.98 1.141	32.94 1.297	35.15 1.384	33.86 1.333	39.30 1.547	47.00 1.850
21		31.75 1.250	32.16 1.266	36.12 1.422	38.28 1.507	37.06 1.459	42.50 1.673	50.60 1.992
23	3.91 0.154	34.93 1.375	34.93 1.375	39.29 1.547	41.50 1.634	40.01 1.575	45.70 1.799	54.20 2.134
25		38.10 1.500	37.69 1.484	42.47 1.672	44.68 1.759	43.41 1.709	48.80 1.921	59.70 2.350

Millimeters Inches



MIL-DTL-38999 Series III Connectors

DEUTSCH DTS and ACT Series Connectors

Keying Options

(Viewed from Mating Face of the Receptacle Connector)

Shell Size	Key Position	Polarization (Degrees)			
		A	B	C	D
09	N	105	140	215	265
	A	102	132	248	320
	B	80	118	230	312
	C	35	140	205	275
	D	64	155	234	304
	E	91	131	197	240
11, 13, 15	N	95	141	208	236
	A	113	156	182	292
	B	90	145	195	252
	C	53	156	220	255
	D	119	146	176	298
	E	51	141	184	242
17, 19, 21, 23, 25	N	80	142	196	293
	A	135	170	200	310
	B	49	169	200	244
	C	66	140	200	257
	D	62	145	180	280
	E	79	153	197	272

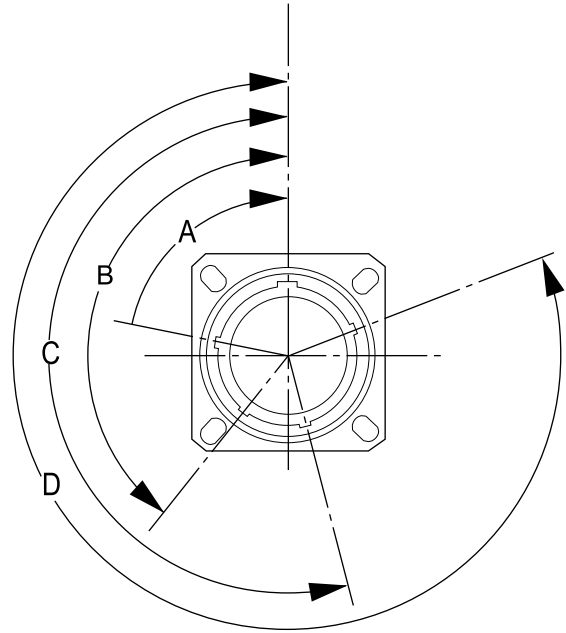

**DEPENDABLE**

- Secure breech lock coupling
- 100% scoop-proof
- Pin-to-pin mating protection helps prevent failures

RUGGED

- Mated connectors help withstand high-impact shock
- Rear accessory threads help provide increased strength
- >500-mating-cycle durability
- Corrosion resistant

EMI PROTECTED

- Grounding fingers for excellent EMI protection
- Connector is grounded when the shells meet, even before the contacts are engaged

EASY INSTALLATION

- Blind-mateable grounding fingers to help provide a safer assembly during mating
- Requires only 90° rotation to engage and disengage

MIL-DTL-38999 Series IV Connectors

**DEUTSCH DIV Series Connectors**

DEUTSCH DIV Series connectors from TE Connectivity (TE) are high-performance MIL-DTL-38999 connectors for use in high shock, vibration and EMI environments where reliability is essential.

Qualified to MIL-DTL-38999 specifications, DEUTSCH DIV Series connectors are designed and built using the high-vibration capable breech lock coupling mechanism that only requires 90° of rotation to engage and disengage.

Special grounding fingers form a 360-degree circle just inside the shell, acting as a shield for excellent EMI protection. The connector is actually grounded when the shells meet, even before the contacts engage.

Inserts are available in 8 shell sizes, with contact arrangements meeting MIL-DTL-1560, along with additional arrangements, to help provide flexibility in circuit configurations.



MIL-DTL-38999 Series IV Connectors

DEUTSCH DIV Series Connectors

Specifications

MATERIALS

- **Shell:** Stainless steel, aluminum
- **Plating:** Olive drab cadmium, passivated, and electroless nickel (anodized coupling ring for Class F only)
- **Insert:** Thermoplastic and fluorinated silicone elastomer
- **EMI Spring Fingers:** Nickel or cadmium-plated beryllium copper
- **O-Ring:** Fluorinated silicone elastomer

ENVIRONMENTAL

- **Temperature Range:**
 - 65°C to +175°C (Class W)
 - 65°C to +200°C (Classes C, F, Y and N)
- **Fluid Resistance:** Fluid immersion per EIA 364.10, including resistance to
 - MIL-PRF-5606: Hydraulic fluid
 - MIL-DTL-83133: JP-8 aviation fuel
 - MIL-PRF-7808: Lubricating oil
 - MIL-PRF-23699: Lubricating oil
 - MIL-A-8243: Deicing/defrosting fluid
 - MIL-C-25769: Aircraft cleaning compound
 - MIL-PRF-87937: Aircraft cleaning compound
 - MIL-G-3056: Gasoline
- **Salt Spray:**
 - 48 hours (Nickel finishes)
 - 500 hours (Cadmium and passivated finishes)
- **Thermal Cycling:** -65° to 150/175/200°C (max. temperature is class dependent)

MECHANICAL

- **Sine Vibration:** Up to 60 g for 36 hr.
- **Random Vibration:** Up to 41.7 g for 16 hr. at 175° C
Up to 50 g for 16 hr. at ambient temperature
- **Shock:** 300 g, 3 ms in the 3 axes
- **Durability:** >500 mating cycles
- **Contact Retention:**
 - Size 22D: 44 N (10 lb.)
 - Size 20: 67 N (15 lb.)
 - Size 16: 111 N (25 lb.)
 - Size 12: 111 N (25 lb.)
 - Size 10: 111 N (25 lb.)
 - Size 8: 111 N (25 lb.)

ELECTRICAL

- **Shell-to-Shell Conductivity:**
 - Olive Drab Cadmium: 2.5 mV
 - Passivated: 10.0 mV
 - Electroless Nickel: 1.0 mV
- **Shielding Effectiveness:** >90 dB at 100 MHz, >65 dB through 10 GHz



MIL-DTL-38999 Series IV Connectors

DEUTSCH DIV Series Connectors

Voltage Rating

Service Rating	Suggested Operating Voltage		Test Voltage at Altitude (VAC _{rms})			
	VAC _{rms}	VDC	Sea Level	50,000 Ft.	70,000 Ft.	100,000 Ft.
M	400	550	1300	550	350	200
N	300	450	1000	400	260	200
I	600	850	1800	600	400	200
II	750	1050	2300	800	500	200

Hermetic Connectors

- **Hermetic Seal:** Sintered glass
- **Leakage:** ≤16 cm³/hr. (0.97 in³/hr.) on mated pairs connected under 2.1 bar (4.38 psi)
- **Thermal Shock:** 10 cycles, 4°C max. to 90°C min.

Current Rating

Contact Size	Test Current (A)	Voltage Drop (mV)
22D	5	73
20	7.5	55
16	13	50
12	23	42
10	33	34
8*	46	26

*When commercial power contact replaces twin-ax contact

Thread Sizes

Shell Size	Accessory Thread (6g 0.100R)	Jam Nut Thread (6g 0.100R)
11	M15 x 1.0	M20 x 1.0
13	M18 x 1.0	M25 x 1.0
15	M22 x 1.0	M28 x 1.0
17	M25 x 1.0	M32 x 1.0
19	M28 x 1.0	M35 x 1.0
21	M31 x 1.0	M38 x 1.0
23	M34 x 1.0	M41 x 1.0
25	M37 x 1.0	M44 x 1.0



MIL-DTL-38999 Series IV Connectors

DEUTSCH DIV Series Connectors

DIV Commercial	Insert		Contact Size/Quantity													Inactive: Superseded by
	Military		8 Twinax	8 Coax	8 Power	12 Twinax	12 Coax	10	12	16	20	22D	QPL	QPL Hermetic	Uses 38999/62-8" Boots	
11-02	B2								2				✓	✓		
11-04	B4									4			✓	✓		
11-05	B5									5			✓	✓		
11-35	B35										13		✓	✓		
11-98	B98									6			✓	✓		
11-99	B99									7			✓	✓		
13-04	C4								4				✓	✓		
13-08	C8									8			✓	✓		
13-35	C35										22		✓	✓		
13-98	C98									10			✓	✓		
15-05	D5								5				✓	✓		
15-15	D15								1	14			✓	✓		
15-18	D18									18			✓	✓		
15-19	D19									19			✓	✓		
15-26	D26								2		24					
15-35	D35										37		✓	✓		
15-97	D97								4	8			✓	✓		
17-02	E2	1									38					17-03
17-03	E3	1									38				✓	
17-06	E6							6					✓	✓		
17-08	E8								8				✓	✓		
17-11	E11				2	1				8						
17-19	E19								4	11	4					
17-20	E20								4		16					
17-22	E22	2							2							
17-24	E24			2							22					
17-26	E26									26			✓			
17-35	E35										55		✓	✓		
17-99	E99								2	21			✓	✓		
19-11	F11								11				✓	✓		
19-18	F18	4									14		✓			19-19
19-19	F19	4									14		✓		✓	
19-28	F28								2	26				✓		
19-32	F32									32			✓			
19-35	F35										66		✓	✓		

Blue shaded entries are not Mil Spec.



MIL-DTL-38999 Series IV Connectors

DEUTSCH DIV Series Connectors

DIV Commercial	Insert		Contact Size/Quantity											Uses 38999/62-8" Boots	Inactive: Superseded by	
	Military		8 Twlnax	8 Coax	8 Power	12 Twlnax	12 Coax	10	12	16	20	22D	QPL			QPL Hermetic
21-11	G11							11					✓	✓		
21-16	G16								16				✓	✓		
21-20	G20		2							18						
21-35	G35										79		✓	✓		
21-39	G39								2	37			✓	✓		
21-41	G41									41			✓	✓		
21-48	G48			4												
21-75	G75		4													21-76
21-76	G76		4												✓	
23-06	H6		6													
23-21	H21								21				✓	✓		
23-35	H35										100		✓	✓		
23-53	H53									53			✓	✓		
23-54	H54							4	9		40					
23-55	H55									55			✓	✓		
23-63	H63							4	4		49					
25-04	J4								8	48			✓	✓		
25-07	J7		2								97					25-09
25-08	J8		8													25-10
25-09	J9		2								97				✓	
25-10	J10		8												✓	
25-17	J17		6								36					
25-19	J19							19					✓	✓		
25-20	J20		3				4		13	10						25-21
25-21	J21		3				4		13	10					✓	
25-24	J24							12	12				✓	✓		
25-29	J29								29				✓	✓		
25-35	J35										128		✓	✓		
25-37	J37								37				✓			
25-43	J43								20	23				✓		
25-46	J46			2					4	40						25-47
25-47	J47			2					4	40					✓	
25-61	J61									61			✓	✓		
25-90	J90		2						4	40						25-91
25-91	J91		2						4	40					✓	

Blue shaded entries are not Mil Spec.



MIL-DTL-38999 Series IV Connectors

DEUTSCH DIV Series Connectors

Wall Mount/Square Flange Receptacle

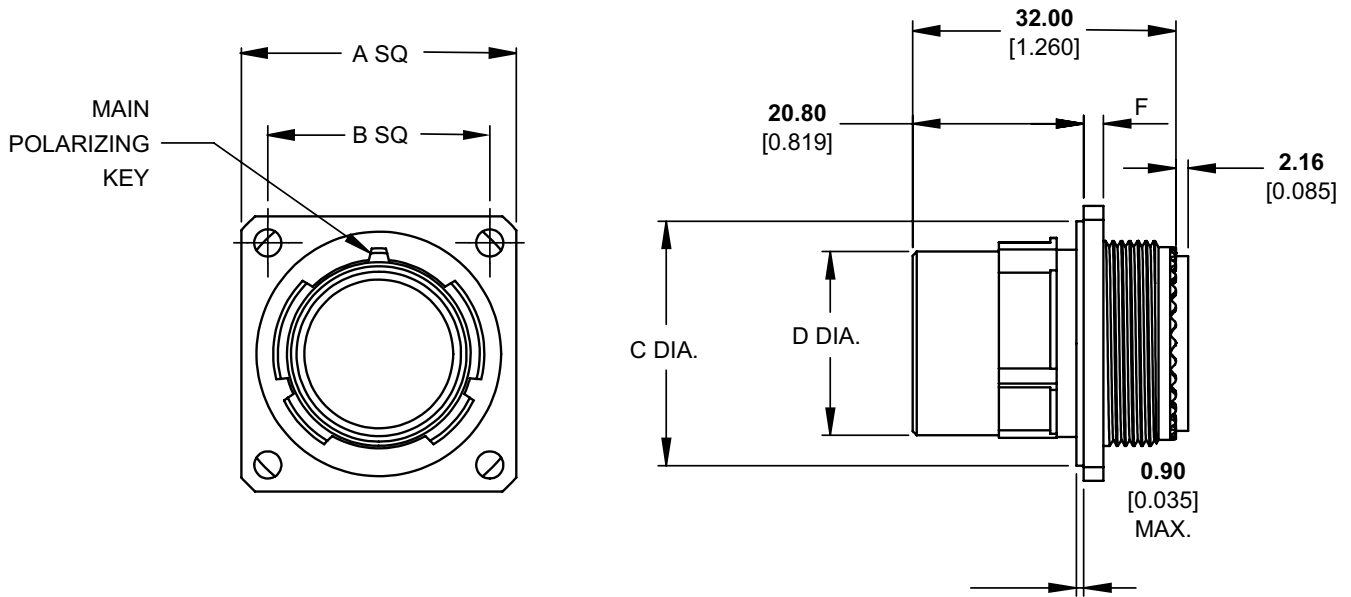

Shell Size	A Sq. Max.	B Sq.	ØC Max.	ØD Max.	F
11	26.70 1.051	20.62 0.812	20.15 0.793	12.93 0.509	2.60 0.102
13	29.10 1.146	23.02 0.906	23.35 0.919	16.10 0.634	2.60 0.102
15	31.50 1.240	24.62 0.970	26.52 1.044	19.28 0.759	2.60 0.102
17	33.90 1.335	26.98 1.062	29.72 1.170	22.48 0.885	2.60 0.102
19	37.10 1.461	29.36 1.156	32.87 1.294	25.63 1.009	2.60 0.102
21	40.20 1.583	31.76 1.250	36.05 1.419	28.80 1.134	3.40 0.133
23	43.40 1.709	34.92 1.374	39.22 1.544	31.98 1.259	3.40 0.133
25	46.60 1.835	38.10 1.500	42.40 1.669	35.15 1.384	3.40 0.133

Millimeters Inches



MIL-DTL-38999 Series IV Connectors

DEUTSCH DIV Series Connectors

Jam Nut Receptacle

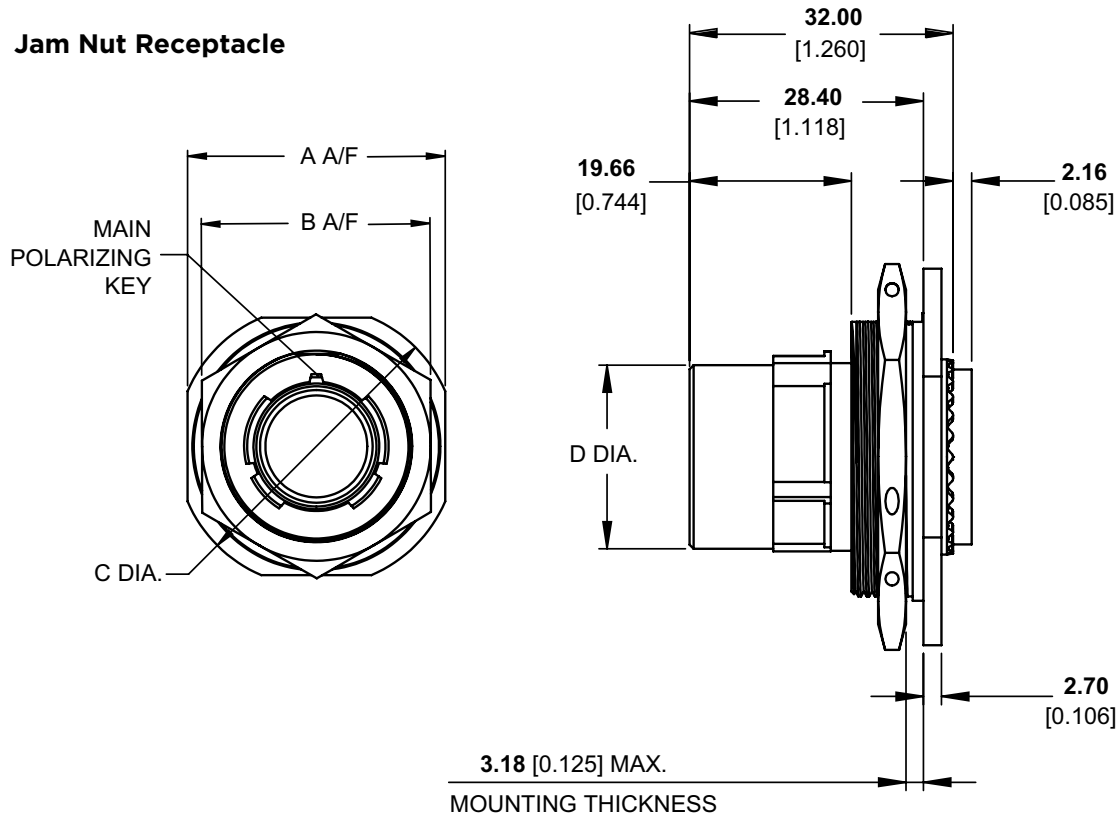

Shell Size	A A/F Max.	B A/F Max.	C Dia. Max.	D Dia. Max.
11	35.40 1.394	32.00 1.260	38.60 1.520	12.93 0.509
13	38.60 1.520	36.00 1.417	41.70 1.642	16.10 0.634
15	41.70 1.642	41.00 1.614	44.90 1.768	19.28 0.759
17	45.70 1.799	41.00 1.614	49.70 1.957	22.48 0.885
19	48.50 1.909	46.00 1.811	51.70 2.035	25.63 1.009
21	51.70 2.035	50.00 1.968	54.80 2.157	28.80 1.134
23	54.80 2.157	50.00 1.968	58.00 2.283	31.98 1.259
25	58.00 2.283	55.00 2.165	61.20 2.409	35.15 1.384

Millimeters Inches



MIL-DTL-38999 Series IV Connectors

DEUTSCH DIV Series Connectors

Box Mount Receptacle

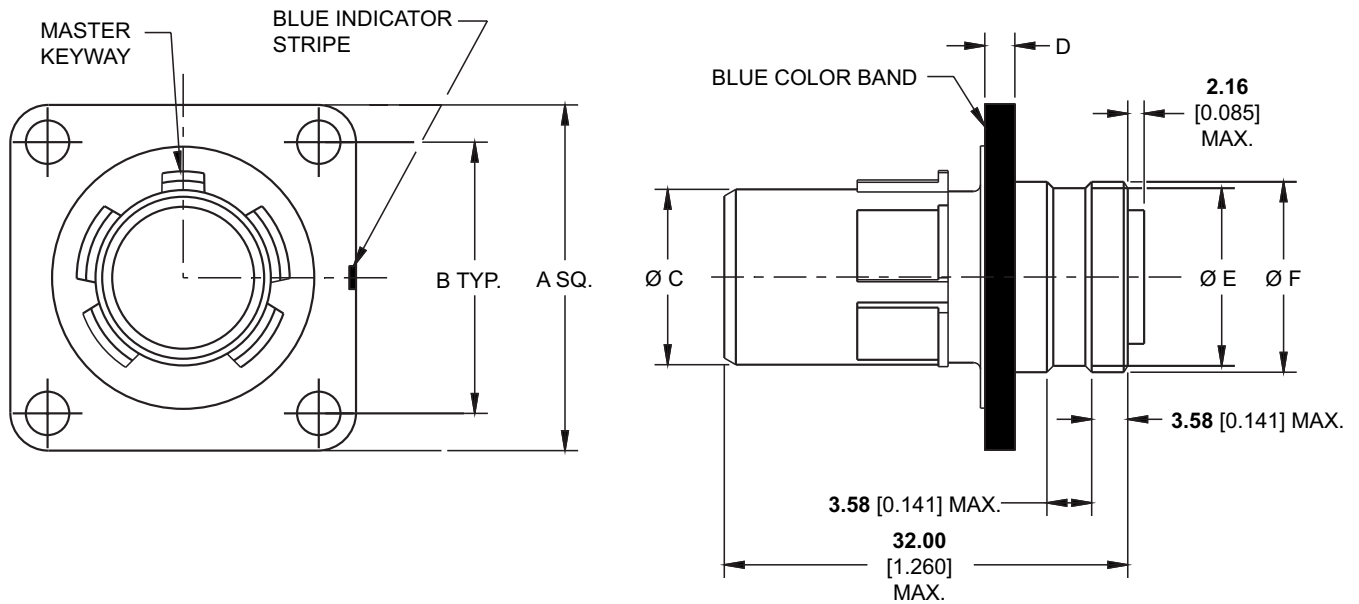

Shell Size	A Sq. Max.	B Sq.	ØC Max.	D	ØE	ØF
11	26.70 1.051	20.62 0.812	20.15 0.793	2.60 0.102	13.41 0.528	14.50 0.571
13	29.10 1.146	23.02 0.906	23.35 0.919	2.60 0.102	16.31 0.642	17.40 0.685
15	31.50 1.240	24.62 0.970	26.52 1.044	2.60 0.102	19.41 0.764	20.60 0.811
17	33.90 1.335	26.98 1.062	29.72 1.170	2.60 0.102	22.61 0.890	23.80 0.937
19	37.10 1.461	29.36 1.156	32.87 1.294	2.60 0.102	25.30 0.996	26.52 1.044
21	40.20 1.583	31.76 1.250	36.05 1.419	3.40 0.133	28.52 1.123	29.620 1.166
23	43.40 1.709	34.92 1.374	39.22 1.544	3.40 0.133	31.70 1.248	32.82 1.292
25	46.60 1.835	38.10 1.500	42.40 1.669	3.40 0.133	34.82 1.371	36.02 1.418

Millimeters Inches



MIL-DTL-38999 Series IV Connectors

DEUTSCH DIV Series Connectors

Plug

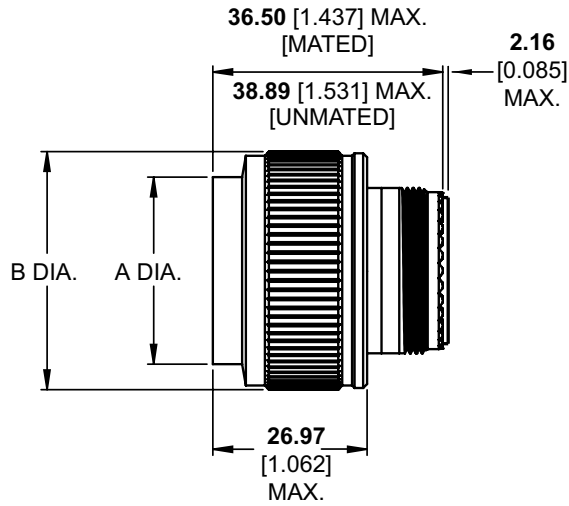

Shell Size	Ø A Max.	Ø B Max.
11	26.60 1.047	19.70 0.775
13	31.00 1.220	22.90 0.901
15	34.20 1.346	26.40 1.039
17	37.40 1.472	29.20 1.149
19	40.20 1.583	32.40 1.275
21	43.30 1.704	35.60 1.401
23	46.50 1.831	38.80 1.527
25	49.70 1.957	41.90 1.649

Millimeters Inches



MIL-DTL-38999 Series IV Connectors

DEUTSCH DIV Series Connectors

Recommended Panel Cutouts

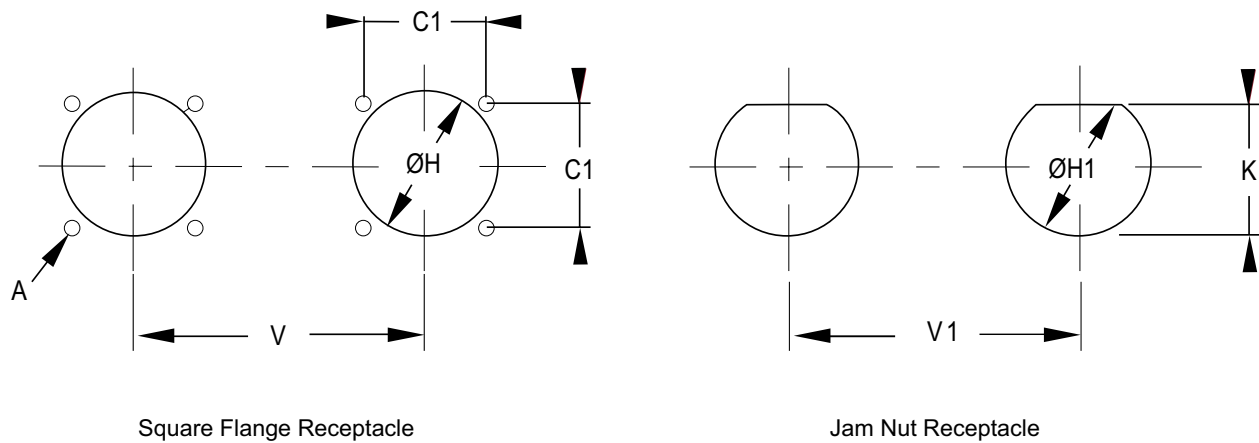

Square Flange Receptacle

Jam Nut Receptacle

Shell Size	C1	H Min.		H1 Max.	K Max.	V Min.	V1 Min.
		Front	Rear				
11	20.62 0.812	15.08 0.594	22.22 0.875	20.88 0.822	19.53 0.769	27.00 1.063	32.60 1.283
13	23.01 0.906	19.05 0.750	23.42 0.922	25.58 1.007	24.26 0.995	30.20 1.189	36.00 1.417
15	24.61 0.969	23.01 0.906	26.59 1.047	28.80 1.134	27.53 1.084	33.30 1.331	39.60 1.559
17	26.97 1.062	25.81 1.106	30.96 1.219	31.98 1.259	30.68 1.208	36.50 1.437	43.30 1.705
19	29.36 1.156	28.98 1.141	32.94 1.297	35.15 1.384	33.86 1.333	39.30 1.547	47.00 1.850
21	31.75 1.250	32.16 1.266	36.12 1.422	38.28 1.507	37.06 1.459	42.50 1.673	50.60 1.992
23	34.93 1.375	34.93 1.375	39.29 1.547	41.50 1.634	40.01 1.575	45.70 1.799	54.20 2.134
25	38.10 1.500	37.69 1.484	42.47 1.672	44.68 1.759	43.41 1.709	48.80 1.921	59.70 2.350

Millimeters Inches



MIL-DTL-38999 Series IV Connectors

DEUTSCH DIV Series Connectors

Keying Options

(Viewed from Mating Face of the Receptacle Connector)

Clocking	X° Ref.	Y° Ref.
N	110	250
A	100	260
B	90	270
C	80	280
D	70	290
K	120	255

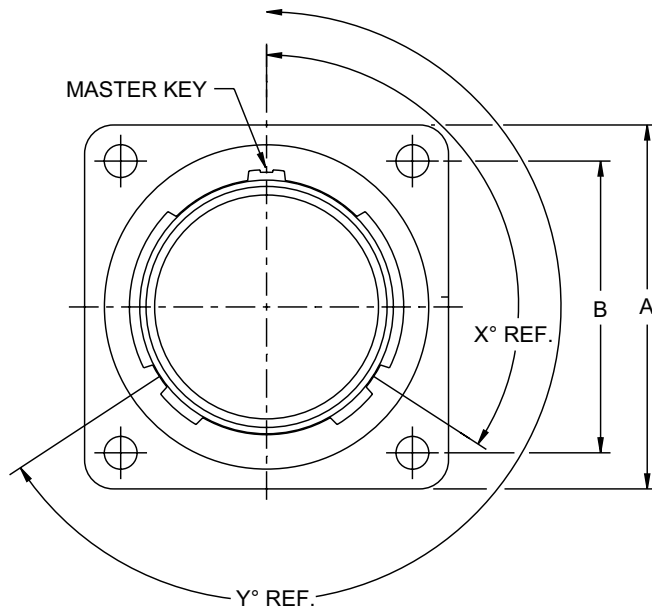



Panel Seals

Panel seals help improve the sealing between the structure and connector shell.

- **Color:** Tan
- **Elastomer:** Fluorosilicone
- **Temperature Range:** -40°C to +93°C

RUGGED

- RoHS

APPLICATIONS

- DataCom
- Military
- Medical

Front Flange Mounting								Rear Flange Mounting		
Size	Part Number	H max.	B max.	C ± 0.1	E max.	E1 max.	T max.	H max.	Part Number	Size
09	108-0003-10	15.40	24.30	18.30	3.00	5.92	3.30	14.10	108-0004-10	09
11	108-0001-12	19.20	26.40	20.60	3.00	5.92	3.30	17.20	108-0004-12	11
13	108-0001-14	22.70	29.10	23.00	3.00	5.92	3.30	20.40	108-0004-14	13
15	108-0001-16	25.90	31.30	24.60	3.00	5.92	3.30	23.60	108-0004-16	15
17	108-0003-18	29.10	33.70	27.00	3.00	5.92	3.30	26.80	108-0004-18	17
19	108-0003-20	32.30	36.90	29.40	3.00	5.92	3.30	30.60	108-0001-20	19
21	108-0003-22	35.40	40.10	31.75	3.00	5.16	3.30	33.50	108-0001-22	21
23	108-0003-24	38.60	43.30	34.90	3.00	5.16	4.30	36.30	108-0004-24	23
25	108-0001-25	41.40	46.00	38.10	3.00	4.87	4.30	39.00	108-0012-25	25

For Square Flange Receptacle Sealed Version

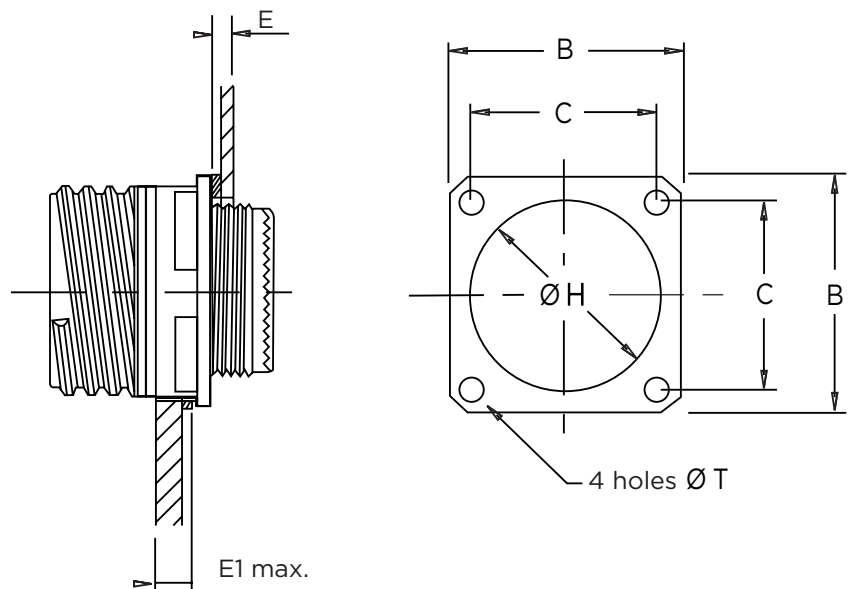



Conductive Panel Seals

In addition to improving sealing, conductive panel seals also improve conductivity and reduce resistivity for EMI improvement between the connector shell and the panel of the structure/system.

- **Color:** Tan
- **Elastomer:** Fluorosilicone
- **Filler:** Silver aluminum
- **Hardness:** 70 ± 7 Shore A
- **Volume Resistivity:** 0.010 ohm-cm, maximum
- **Density:** 2.0 ± 0.25 g/cm³
- **Tensile Strength:** 200 psi, minimum
- **Elongation:** 60%-260%
- **100%-300%:** 35 ppi, minimum
- **Temperature Range:** -55°C to +160°C

RUGGED

- Material achieves the performances of MIL-DTL-83528 Type D
- Extended temperature range
 - Improves standard environmental resistance
- Provides strong EMI protection
- RoHS

APPLICATIONS

- DataCom
- Military
- Medical

Square Flange Receptacle Shell Size	Conductive (Front) Panel Seal Refs
9 / A	PC-CO161FAB0032-126 SIZE 09-SAFS
11 / B	PC-CO162FAB0032-126 SIZE 11-SAFS
13 / C	PC-CO138FAB0032-126 SIZE 13-SAFS
15 / D	PC-CO163FAB0032-126 SIZE 15-SAFS
17 / E	PC-CO164FAB0032-126 SIZE 17-SAFS
19 / F	PC-CO165FAB0032-126 SIZE 19-SAFS
21 / G	PC-CO136FAB0032-126 SIZE 21-SAFS
23 / H	PC-CO137FAB0032-126 SIZE 23-SAFS
25 / J	PC-CO166FAB0032-126 SIZE 25-SAFS

GASKET 09

D38999/20 Series III (Shell Size 09)

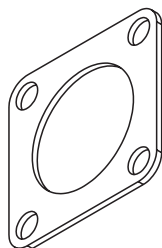
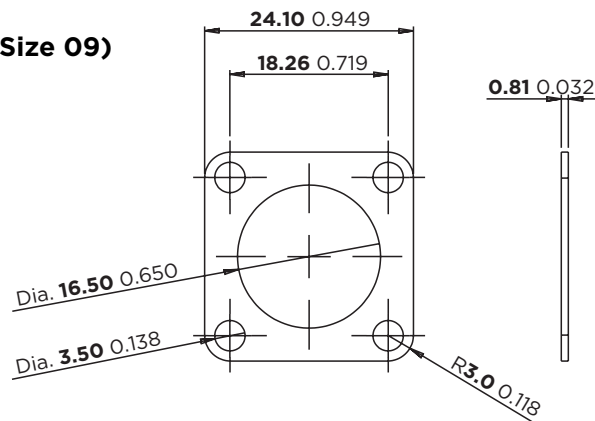

Millimeters Inches



Conductive Panel Seals

GASKET 11
D38999/20 Series III (Shell Size 11)

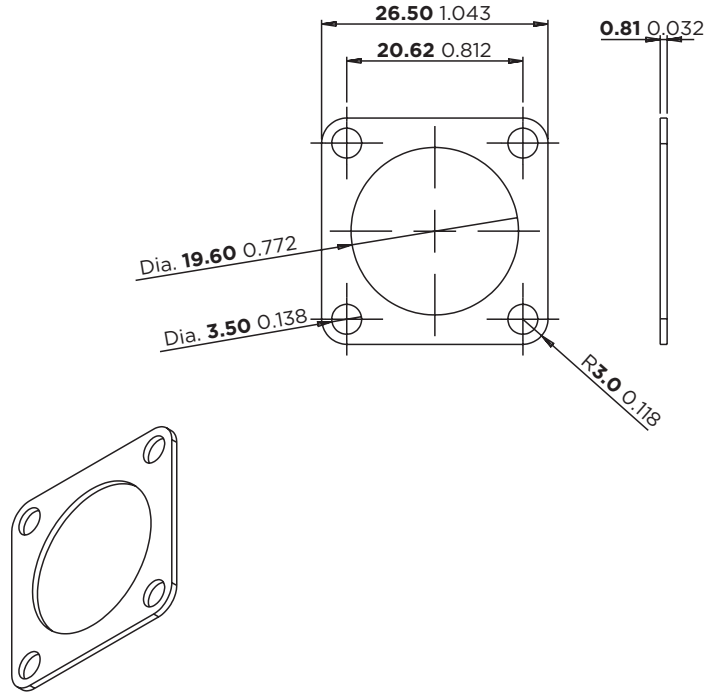

Millimeters Inches

GASKET 13
D38999/20 Series III (Shell Size 13)

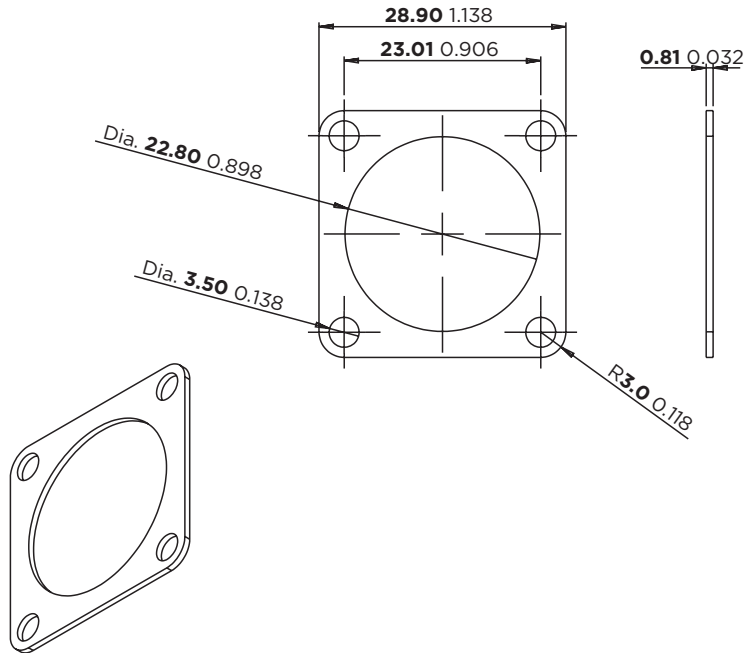

Millimeters Inches



Conductive Panel Seals

GASKET 15
D38999/20 Series III (Shell Size 15)

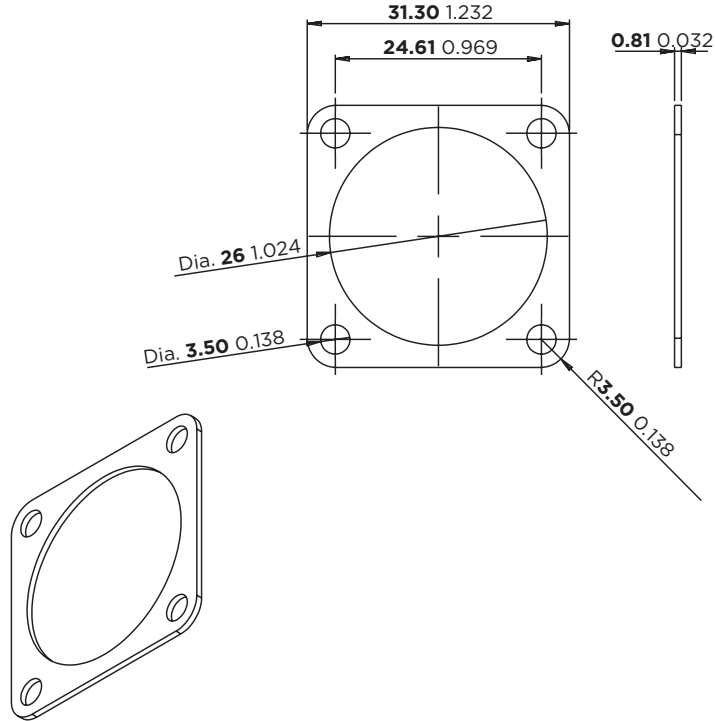

Millimeters Inches

GASKET 17
D38999/20 Series III (Shell Size 17)

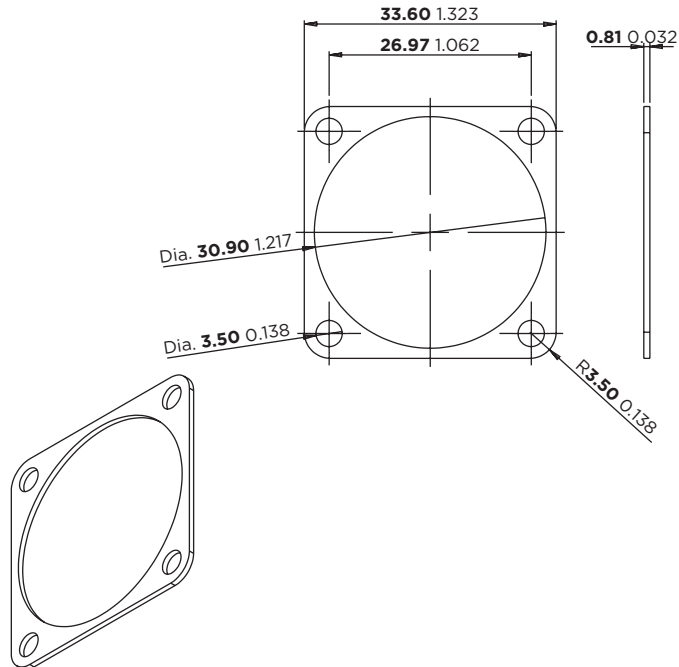

Millimeters Inches



Conductive Panel Seals

GASKET 19
D38999/20 Series III (Shell Size 19)

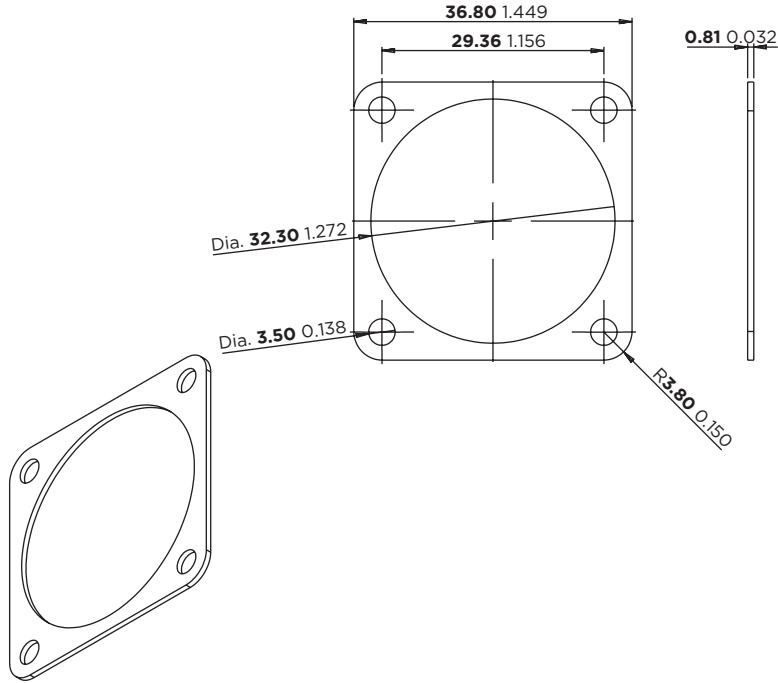

Millimeters Inches

GASKET 21
D38999/20 Series III (Shell Size 21)

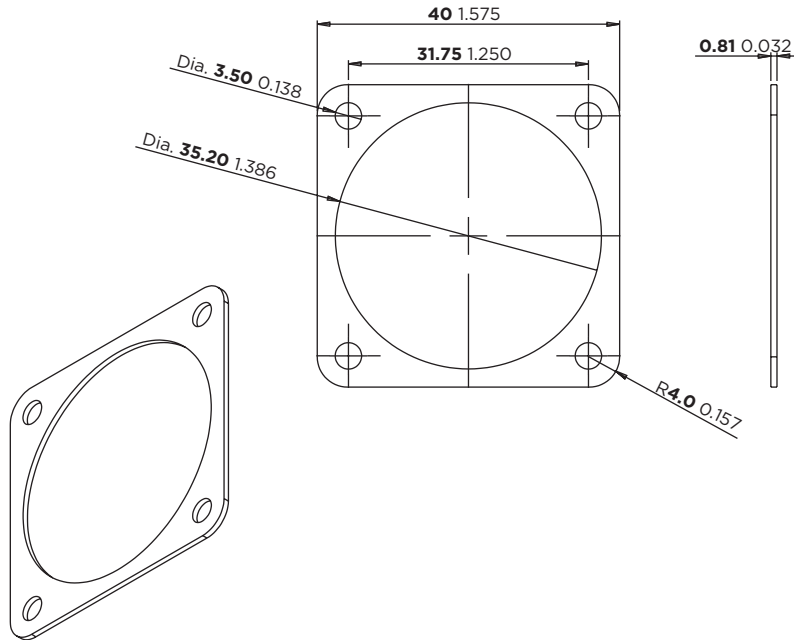

Millimeters Inches



Conductive Panel Seals

GASKET 23

D38999/20 Series III (Shell Size 23)

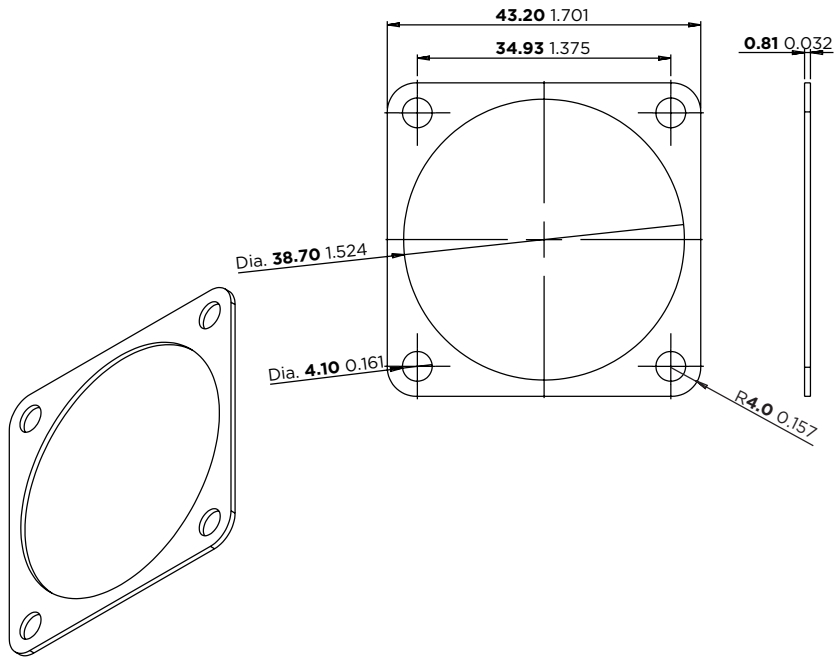

Millimeters Inches

GASKET 25

D38999/20 Series III (Shell Size 25)

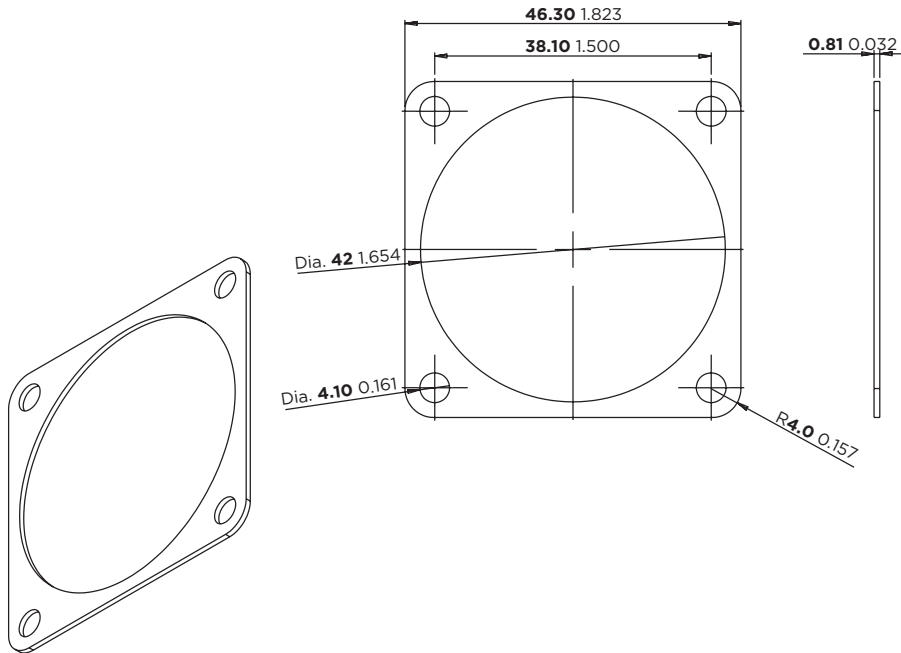

Millimeters Inches

**EXTREME TEMPERATURE**

- -65°C to +200°C

AIRTIGHT/VACUUM

- $<1 \times 10^{-7}$ cm³/s @ 14.7 psi

ENVIRONMENTAL CONDITIONS

- Fluid resistance
- Corrosion resistance
- High vibration

APPLICATIONS

- Sensors
- Fuel tank systems
- Down-hole drilling equipment
- Electronic equipment
- Engine accessories
- Pyrotechnic equipment
- Vacuum chambers
- Optical devices
- Missiles
- Avionics
- Sealed environments

MIL-DTL-38999 Hermetic Connectors

Since the early 1960s TE Connectivity has been producing DEUTSCH hermetically sealed glass-to-metal connectors for applications where temperature, pressure, and environmental considerations render standard connectors unusable. Hermetic connectors are used to separate an inert atmosphere or vacuum on one side from wide-ranging high-pressure, high temperature, or corrosive conditions on the other. They are also used to maintain a pressure differential between the two sections. In short, DEUTSCH hermetic connectors are designed to help provide a continuously gas-tight seal while withstanding:

- High pressures
- Extreme temperatures
- High vibration

Hermetic connectors are also an excellent choice when you are not exactly sure of the conditions that will affect your connector's performance. Hermetic connectors may meet many of the most rigid environmental and electrical specifications, which is important when dealing with variables that are unknown.

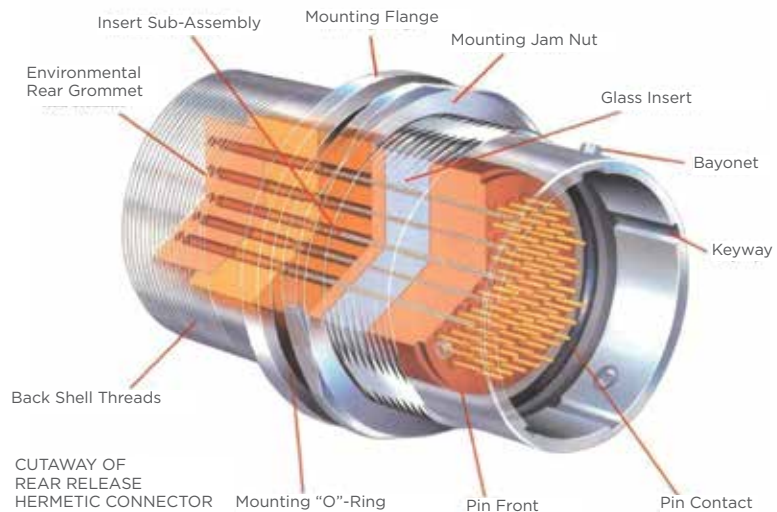
**Glass-to-Metal Sealing**

Standard sealing techniques—such as epoxy potting—are useful in many applications, but they may not provide the degree of sealing that is offered by glass-to-metal hermetic seals. This is especially true of applications with high pressure differentials. Glass is a durable, high-strength material that resists extreme changes in temperature or pressure.

Our glass-to-metal seals create a bond between shell, insulator, and contacts by fusing the glass insulator to the metal components. The bond can maintain a helium leak rate of .01 micron ft³/h at 14.7 psi. The hermetic bond helps provide enduring reliability, resists cracking that would compromise the performance, and helps withstand a wide range of harsh conditions.



MIL-DTL-38999 Hermetic Connectors

Compression vs. Matched Seals

DEUTSCH hermetic connectors are produced using both compression seals and matched seals. In a matched seal, the metal and glass have similar coefficients of thermal expansion (CTE). This reduces stress on the glass from thermal expansion and contraction.

In a compression seal, the metal has a higher CTE than the glass. During the firing process the metal expands more than the glass. As the glass and metal then cool, the metal contracts back onto the glass to form an extremely robust bond. Compression seals are used for high-pressure applications.

Controlling Quality from Start to Finish

We design and manufacture all the components in our hermetic connectors. Our shells are made with high-grade materials—from stainless steel bar stock to exotic metals like titanium. We use high-grade silica and binders for the glass and the elastomer materials are carefully matched to the required connector application. When fused with the contacts and the shell, the inserts produce a true hermetic seal. Pin or socket contacts are available with solder pot, eyelet, and extended pin terminations. Our contacts can be made from a variety of materials like nickel iron, Alumel, Chromel, and copper-cored nickel iron. An important consideration in material selection is the ability to withstand the high temperatures of the sealing process. All connectors are fully leak tested by TE to help ensure the integrity of the hermetic seal.

Materials

Standard materials for hermetic connectors include:

- **Shell:** Stainless steel
- **Insert:** Glass
- **Contacts:** Nickel iron (52 Alloy)

Other materials are used, depending on special requirements for:

- High current
- High voltages
- High pressures
- Extreme temperatures
- Severe corrosion conditions

Weight-Saving Aluminum Hermetic Connectors

DEUTSCH aluminum hermetic connectors use an aluminum alloy shell to create connectors that are 60% lighter than stainless steel counterparts—two aluminum connectors weigh less than a single stainless steel equivalent.

- Up to 60% lighter
- Higher conductivity: up to 250 A
- Lower contact resistance: less than half that of nickel-iron contacts
- Wide temperature range: -85°C to +300°C

A Full Range of Hermetic Choices

DEUTSCH hermetic connectors are available in a variety of military and commercial styles. Options include a choice of:

Pin or socket contacts: Available with solder pot, eyelet, and extended pin terminations

Rear-release crimp termination to help reduce costs by eliminating soldering processes and potting and by allowing use of standard crimp tools

Feedthroughs provide a single device that can be terminated on both sides

Hermetic assemblies with connectors pre-installed in a mounting fixture to reduce your manufacturing time and speed installation

Custom connectors and configurations for applications not easily accommodated by standard offerings. Hermetic connectors lend themselves well to short production runs.



MIL-DTL-38999 Hermetic Connectors

	Military Part No.	DEUTSCH Part No.	Mount Type	Mil Class	Contact Styles
Series I Scoop-proof bayonet coupling	MS27469	DJT10	Wall	H: Space grade Y: Electro-polished stainless steel	
	MS27470	DJT14	Jam Nut		
	MS27471	DJT11	Solder		
Series II Non-scoop-proof, bayonet coupling, low silhouette	MS27475	DJL18	Wall	H: Space grade Y: Electro-polished stainless steel	Pins: P = Solder cup X = Eyelet C = Feedthrough
	MS27476	DJL10	Box		
	MS27477	DJL14	Jam Nut		
	MS27478	DJL11	Solder		
Series III Scoop-proof, triple start, self-locking, threaded coupling	D38999/21	DTS20	Box	H: Space grade N: Nickel plate over stainless steel Y: Electro-polished stainless steel	Socket: S = Solder cup Z = Eyelet D = Feedthrough
	D38999/23	DTS24	Jam Nut		
	D38999/25	DTS21	Solder		
	D38999/27	DTS23	Weld		
Series IV Scoop-proof, breech coupling	D38999/41	DIV40	Box	H: Space Grade N: Nickel plate over stainless steel Y: Electro-polished stainless steel	
	D38999/43	DIV44	Jam Nut		
	D38999/45	DIV41	Solder		



VERSATILE

- Variety of tail and standoff lengths
- Custom extended lengths available
- Choice of finishes

FLEXIBLE

- Contacts available alone or assembled in connectors

PC Tail Contacts and Connectors



TE 38999 connectors are available with PC tail contacts for mounting to pc boards or flex circuits. Alignment disks featured on the high density PCB connectors provide a fitting pattern on the tail side, making installation easier.

PC Contact Part Numbering System

D3 J F A35 P N 1 B W G

BASIC IDENTIFIER

- D3** Extended Pin 38999-Style Receptacle Connector

MOUNTING STYLE

- B** Box Mount
- C** Square Flange with Clinch Nuts
- D** Double Flange
- H** Square Flange with Helicoils
- J** Jam Nut
- S** Square Flange (Standard)

CLASS

- F** Aluminum, Nickel Plated
- G** Aluminum, Nickel Plated, Space Grade
- J** Composite, Olive Drab Cadmium Plated
- M** Composite, Nickel Plated
- T** Aluminum, PTFE Nickel Plated
- W** Aluminum, Olive Drab Cadmium Plated
- Z** Aluminum, Black Zinc Nickel Plated

SHELL SIZE

A (9), B (11), C (13), D (15), E (17), F (19), G (21), H (23), J (25)

INSERT ARRANGEMENT

See Insert Arrangement Table

CONTACT STYLE

- P** Pin
- S** Socket

KEYING

- N** Normal
- A, B, C, D, E**

EXTENDED TAIL FINISH

- G** Gold
- T** Tin/Solder Dip

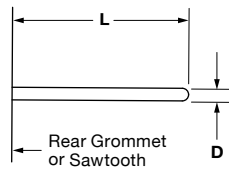

SOLDER LEG DIAMETER (D ±0.001): NO STANDOFFS

	Contact Size			
	Size 22	Size 20	Size 16	Size 12
N	0.635 0.025	1.02 0.040	2.03 0.080	2.39 0.094
W	0.48 0.019	0.48 0.019	1.02 0.044	1.57 0.062
T	0.48 0.019	0.48 0.019	1.57 0.062	1.57 0.062
U	0.71 0.028	0.71 0.028	1.57 0.062	1.57 0.062

CONTACT EXTENSION LENGTH (L)

See Tables

REAR CONFIGURATION

- 1** Epoxy Seal
- 2** Grommet Seal



PC Tail Contacts and Connectors

Jam Nut Receptacles

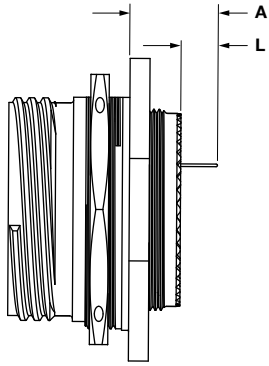

Code	Dim L			Dim A	
	From Grommet	From Sawtooth		From Front of Jam Nut Flange	
	All	Aluminum	Composite	Aluminum	Composite
A	4.14 0.163	4.14 0.163	2.92 0.115	13.54 0.533	13.74 0.541
B	5.33 0.210	5.33 0.210	4.11 0.162	14.73 0.580	14.94 0.588
C	5.84 0.230	5.84 0.230	4.62 0.182	15.24 0.600	15.44 0.608
D	6.76 0.266	6.76 0.266	5.54 0.218	16.05 0.632	16.36 0.644
E	7.98 0.314	7.98 0.314	6.50 0.256	17.37 0.684	17.32 0.682

Millimeters Inches

Square Flange Receptacles

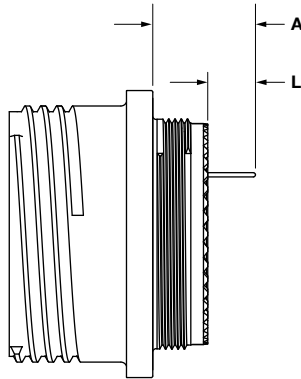

Code	Dim L			Dim A			
	From Grommet	From Sawtooth		Distance from Square Flange			
	All	Aluminum	Composite	Shell Sizes 9-19		Shell Sizes 21-25	
				Aluminum	Composite	Aluminum	Composite
A	4.14 0.163	4.42 0.174	3.94 0.155	13.97 0.550	13.11 0.516	13.39 0.527	13.11 0.516
B	5.33 0.210	5.61 0.221	5.13 0.202	15.16 0.597	14.30 0.563	14.58 0.574	14.30 0.563
C	5.84 0.230	6.12 0.241	5.64 0.222	15.67 0.617	14.81 0.583	15.09 0.594	14.81 0.583
D	6.76 0.266	7.04 0.277	6.55 0.258	16.59 0.653	15.72 0.619	16.00 0.630	15.72 0.619
E	7.98 0.314	8.26 0.325	7.77 0.306	17.81 0.701	16.94 0.667	17.22 0.678	16.94 0.667

Millimeters Inches



PC Tail Contacts and Connectors

Box Mount Receptacles

Code	Dim L
A	9.78 0.385
D	12.40 0.488
J	7.67 0.302

Millimeters Inches
Only epoxy seal (1) available for Box Mount Receptacles

Double Flange Receptacles

Code	Dim L
E	1.68 0.066
F	2.97 0.117
G	4.62 0.182
H	5.64 0.222

Millimeters Inches



9-06/9-35

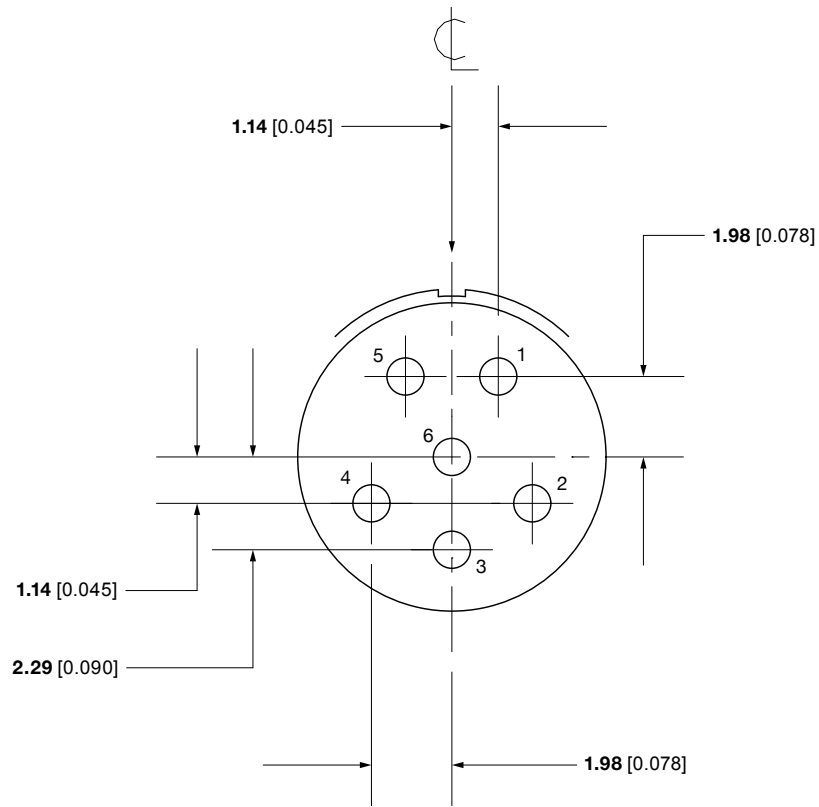

9-44

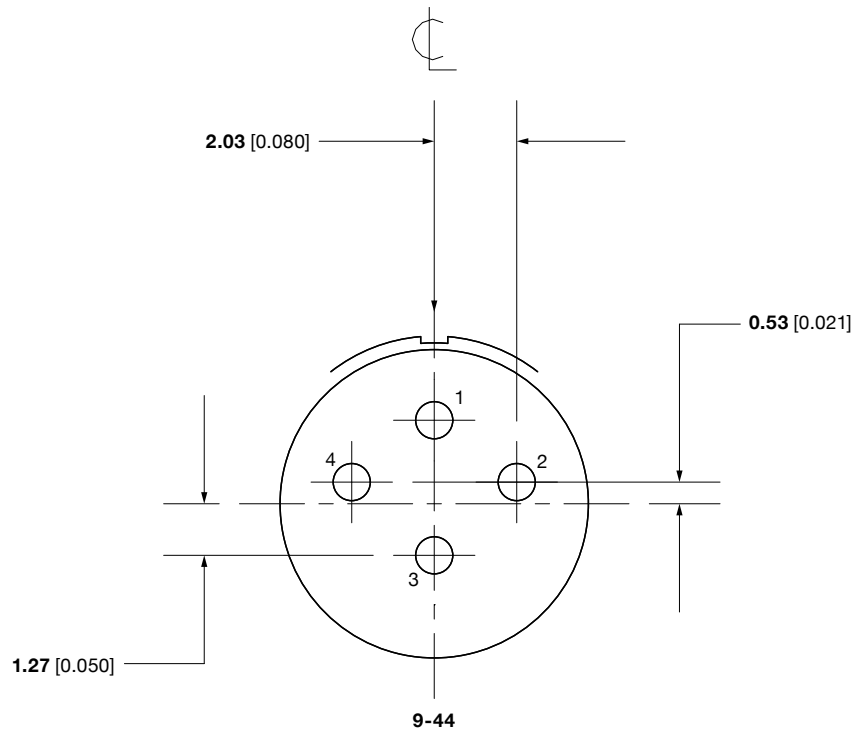



9-98

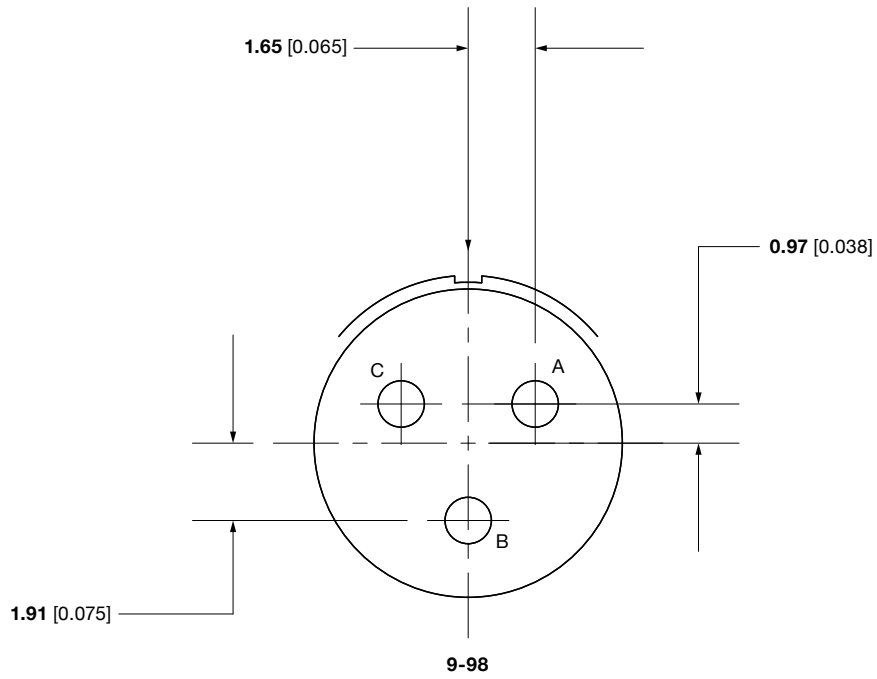

11-02

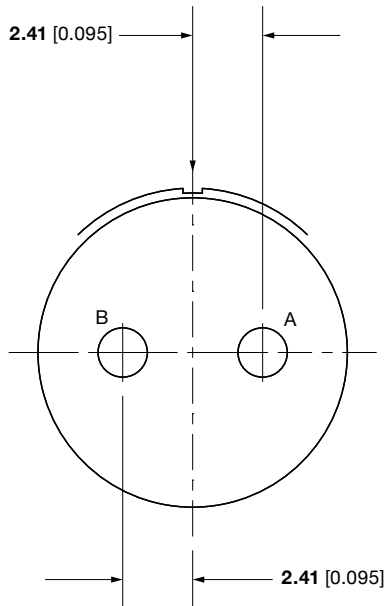



11-04

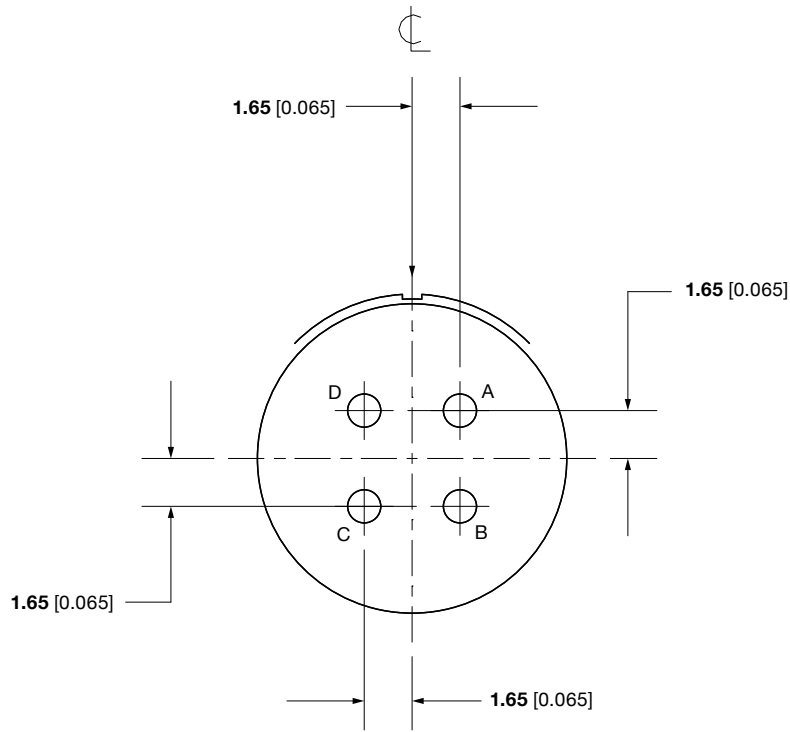

11-05

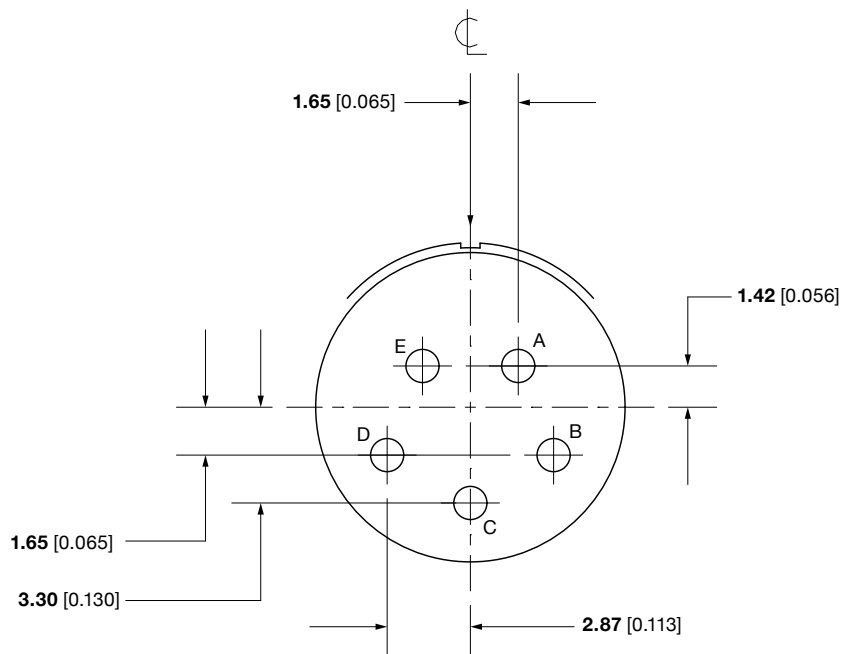



11-13/11-35

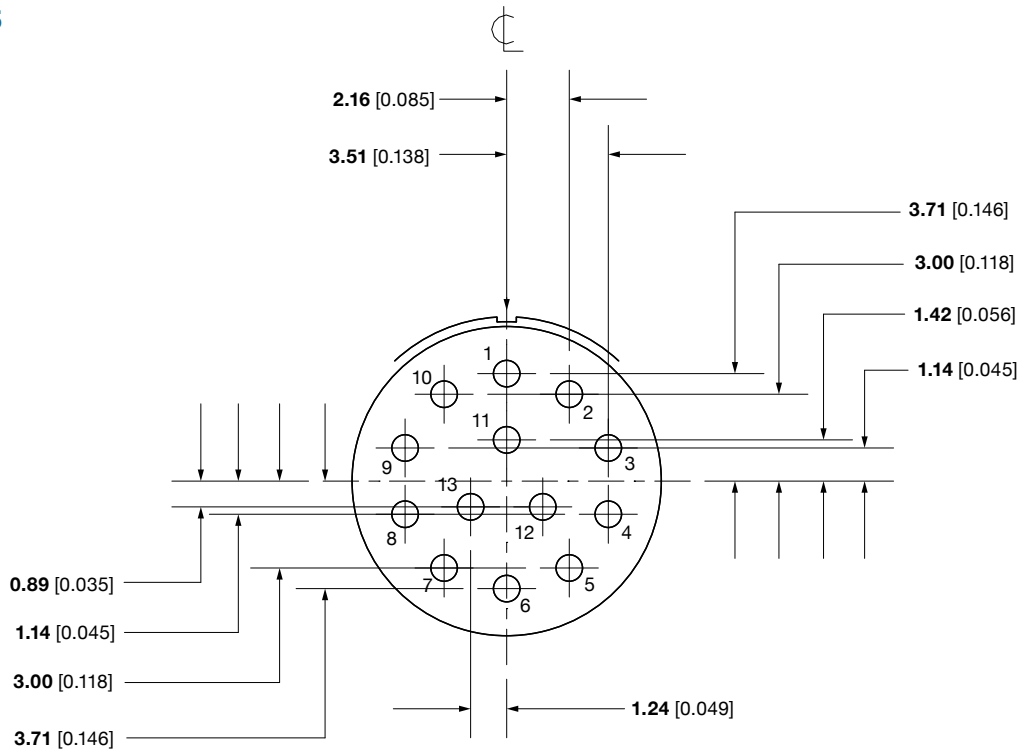

11-98

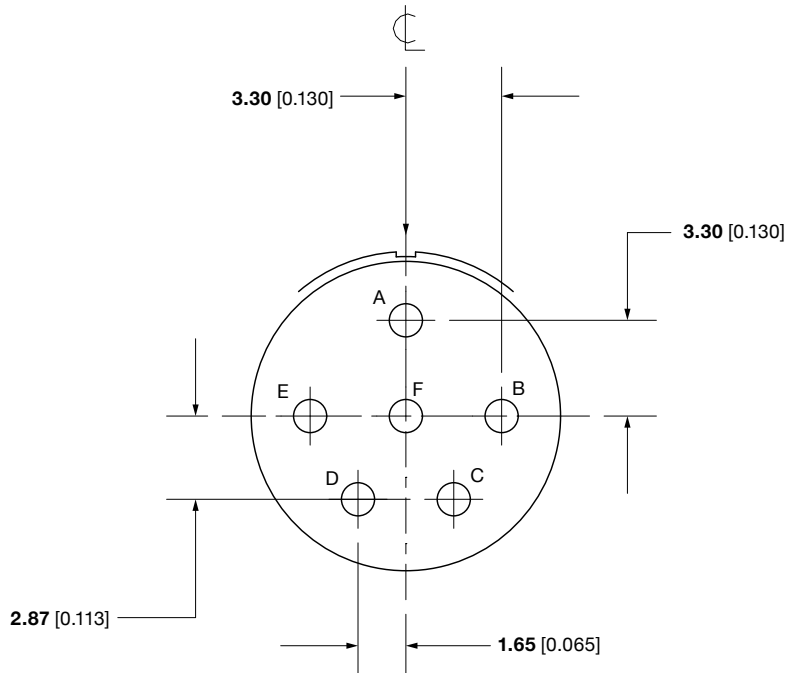



11-99

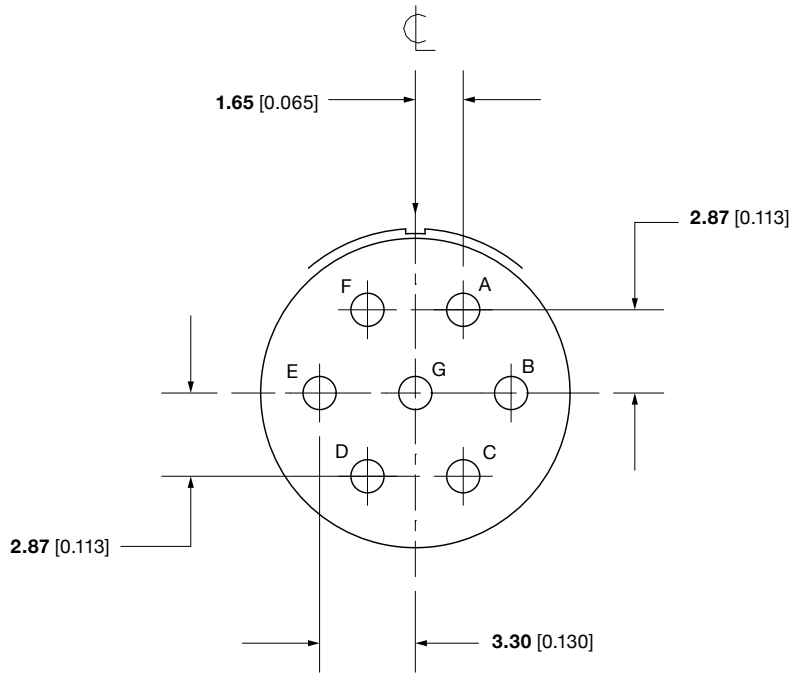

13-04

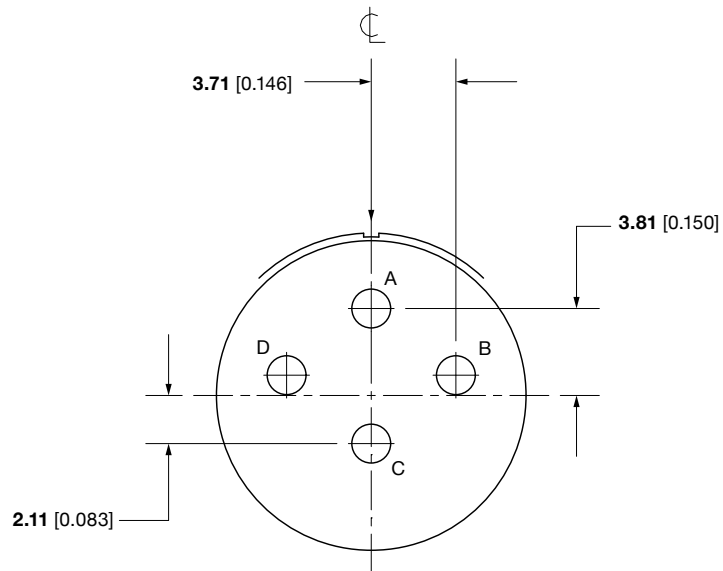



13-08

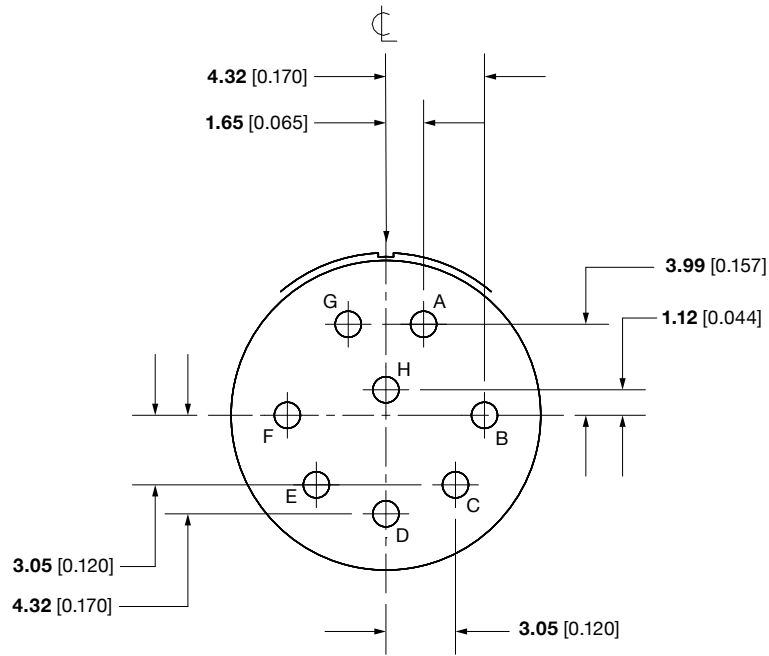

13-22/13-35

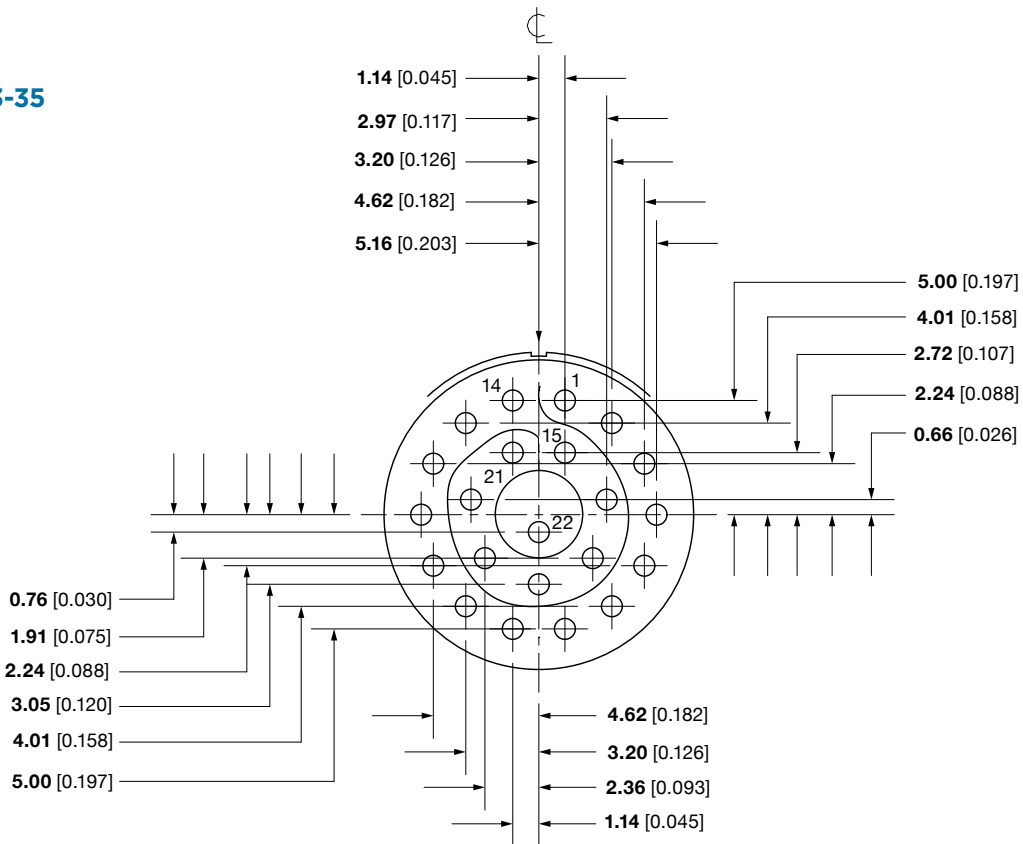



13-98

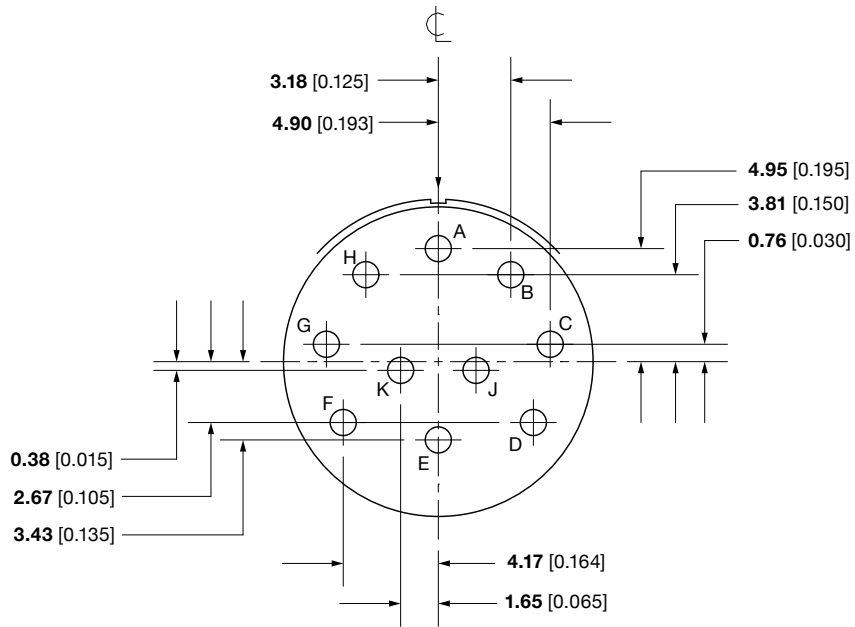

15-05

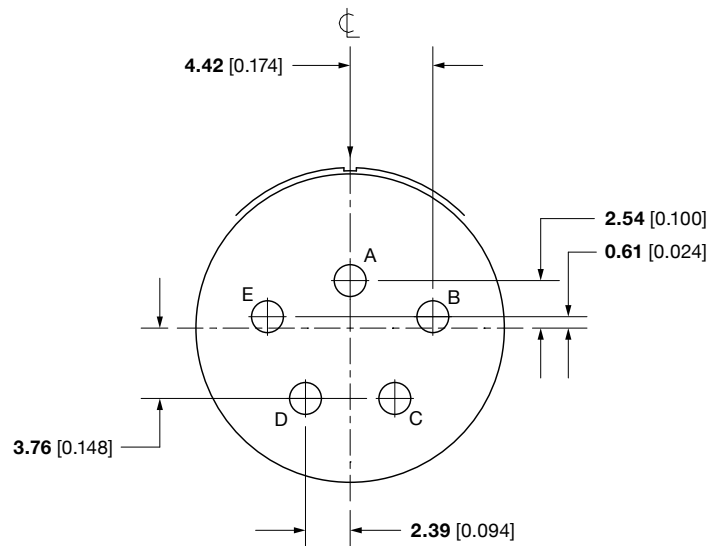



15-15

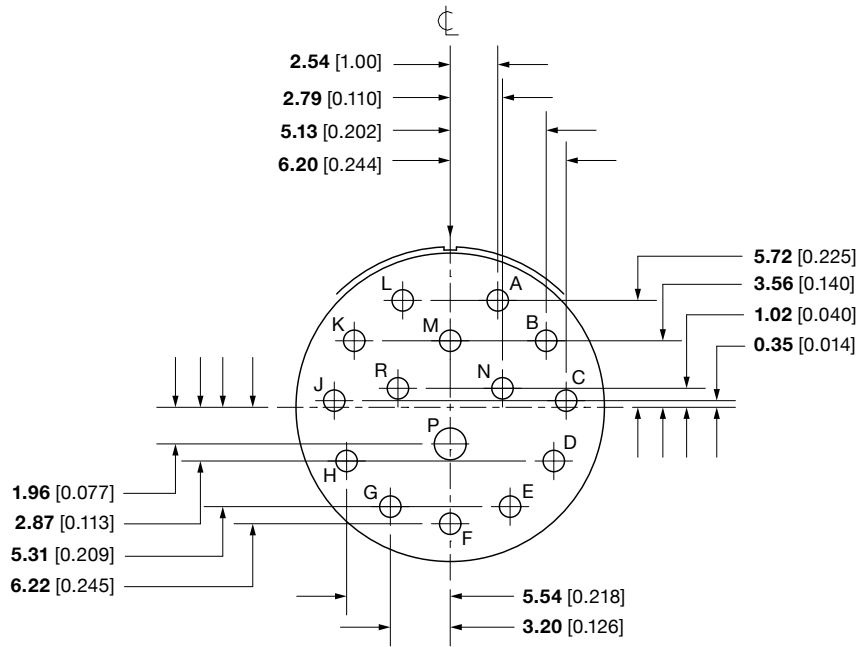

15-18

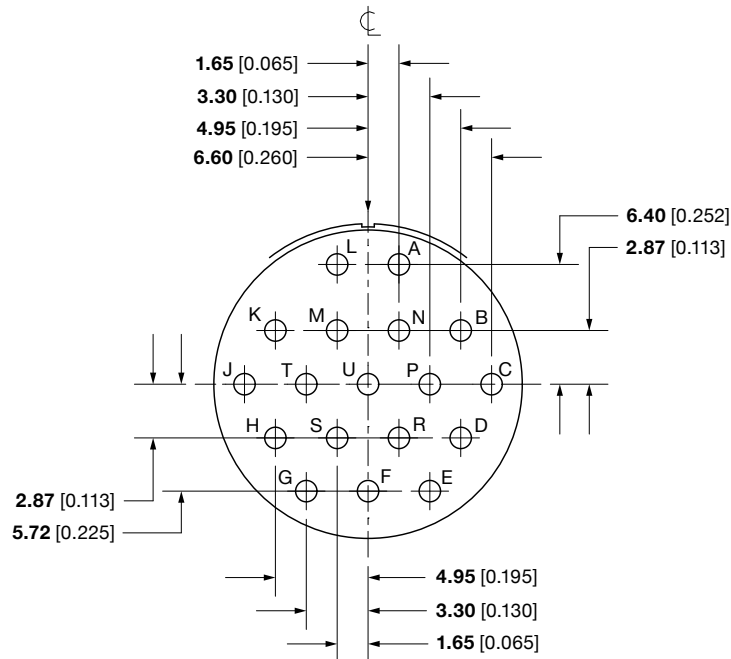



15-19

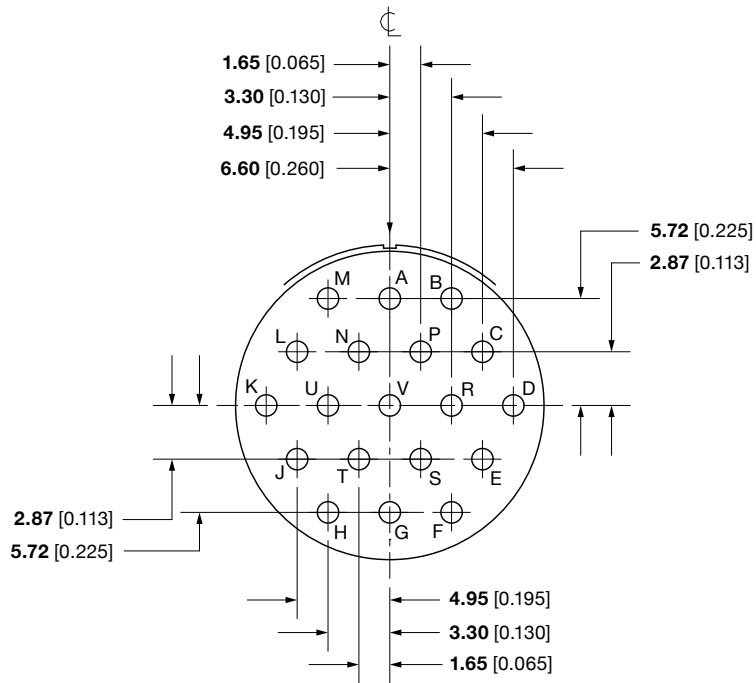

15-35/15-37

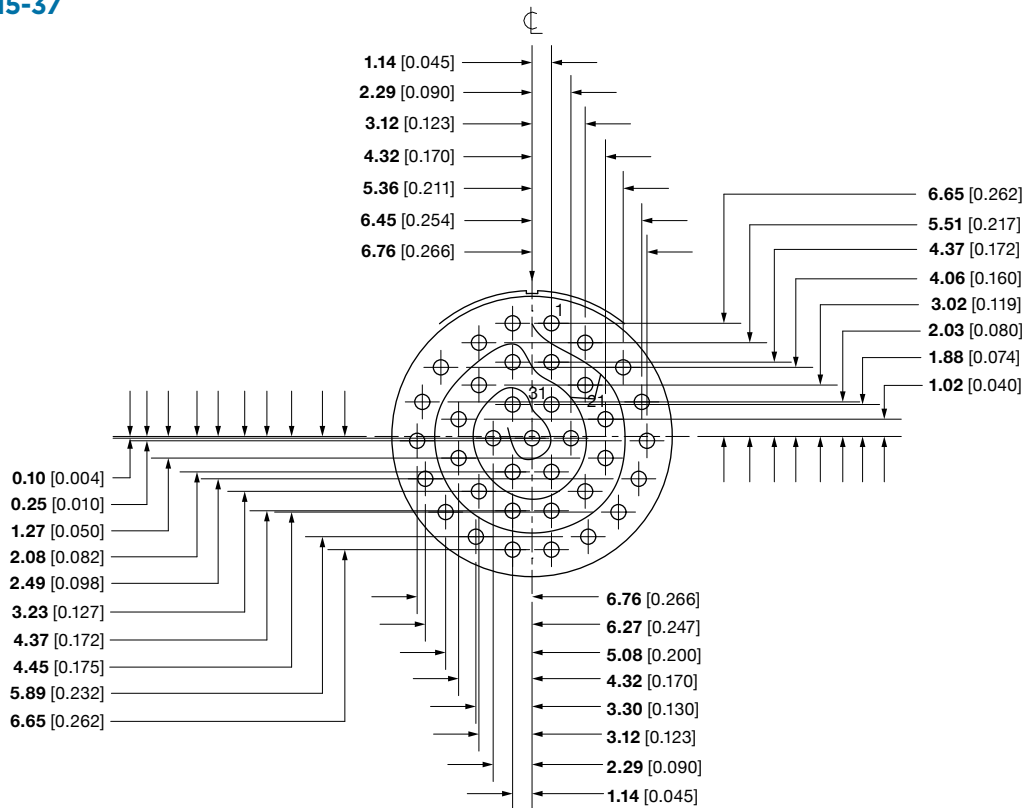

15-35



15-97

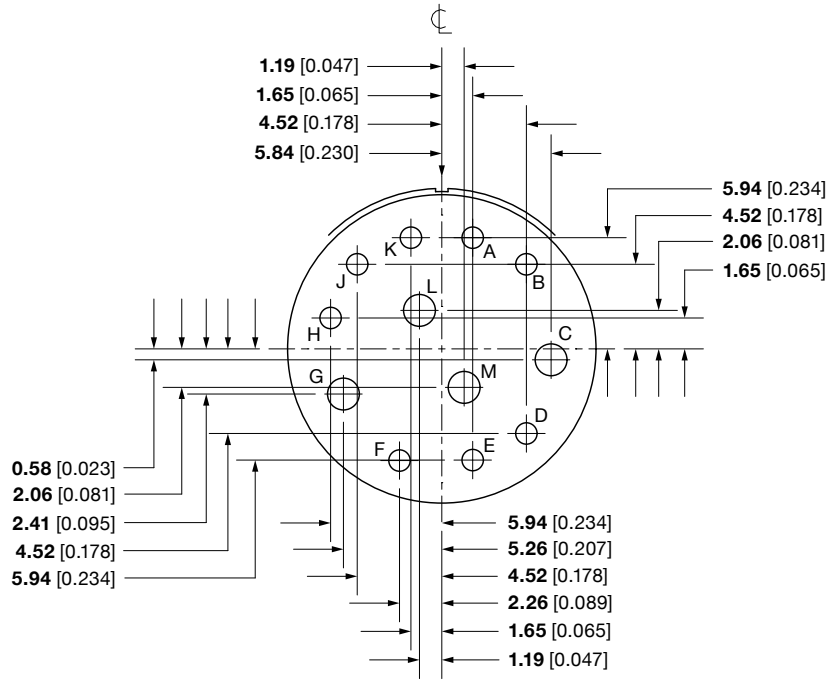

17-06

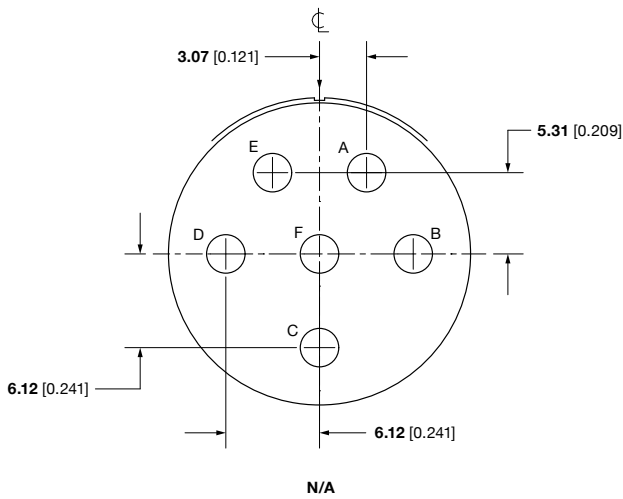

17-08

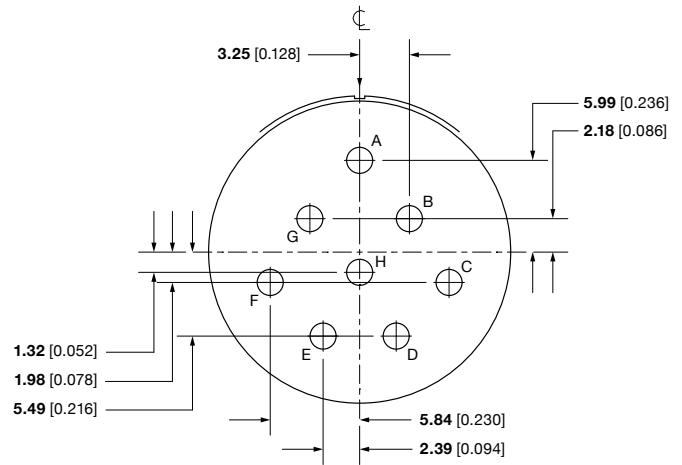



17-26

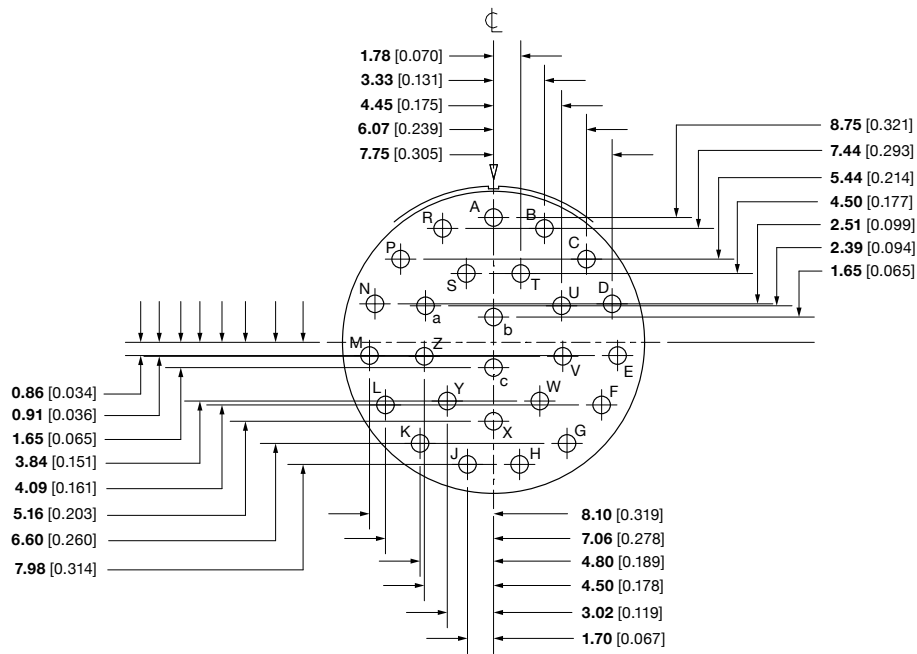

17-35/17-55

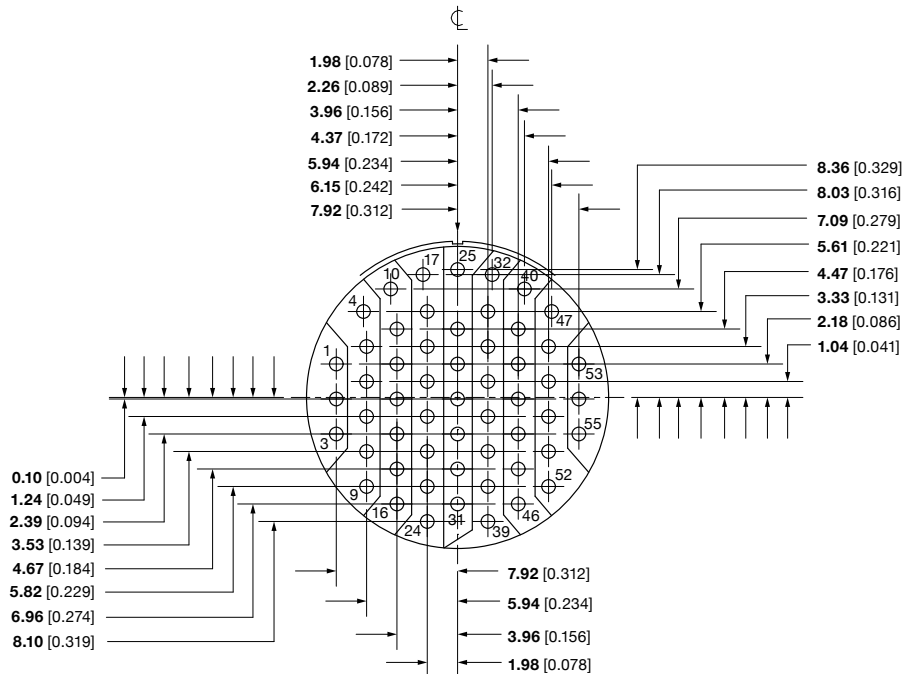



17-99

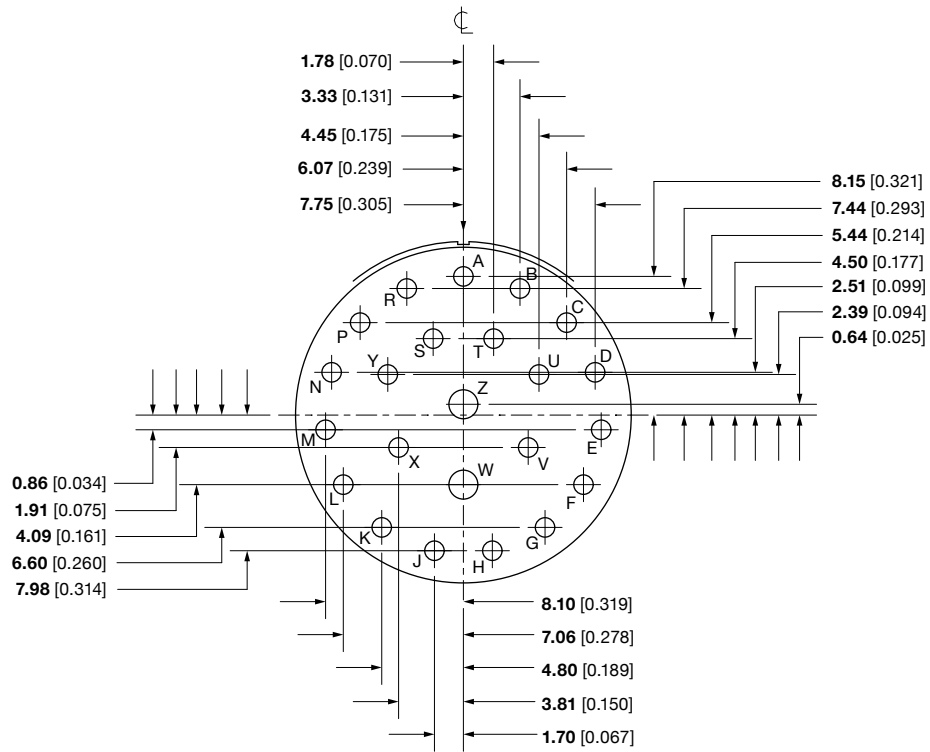

19-11

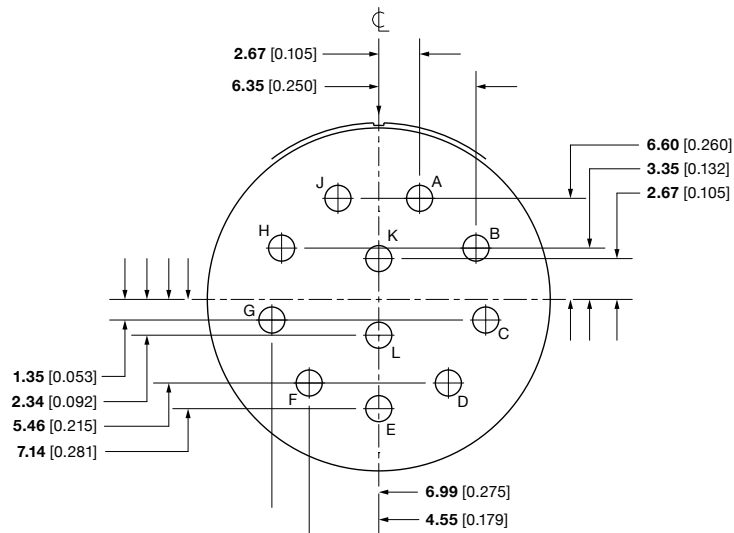



19-28

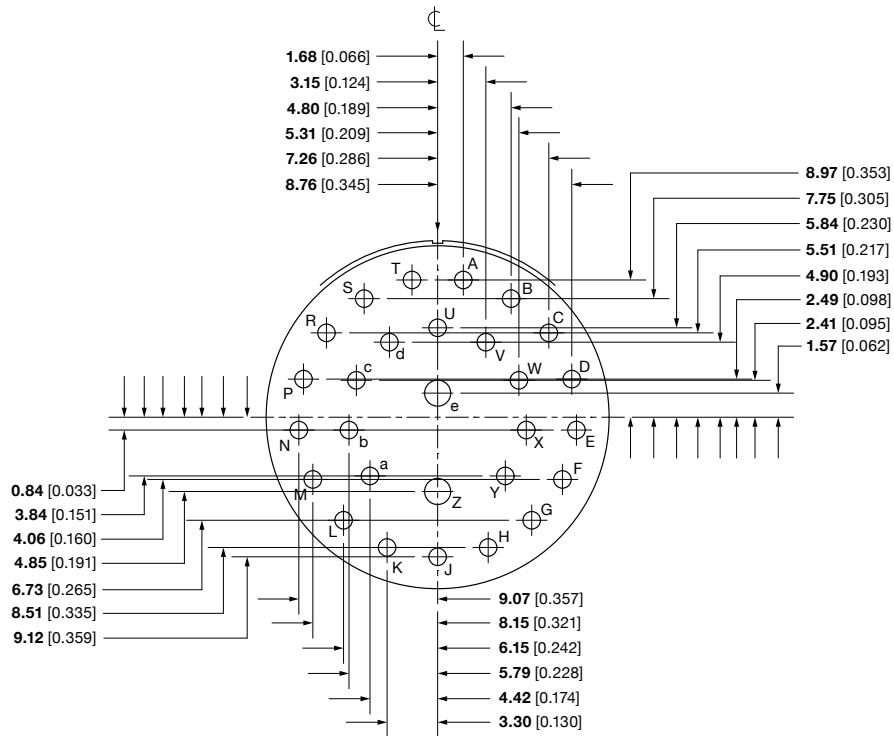

19-30

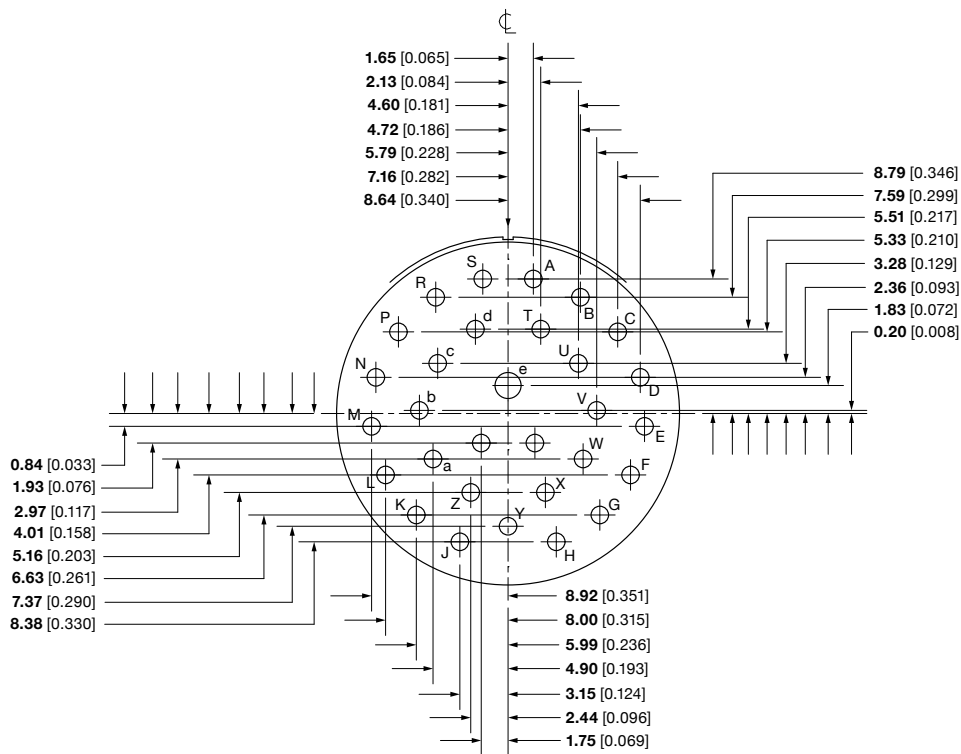



19-32

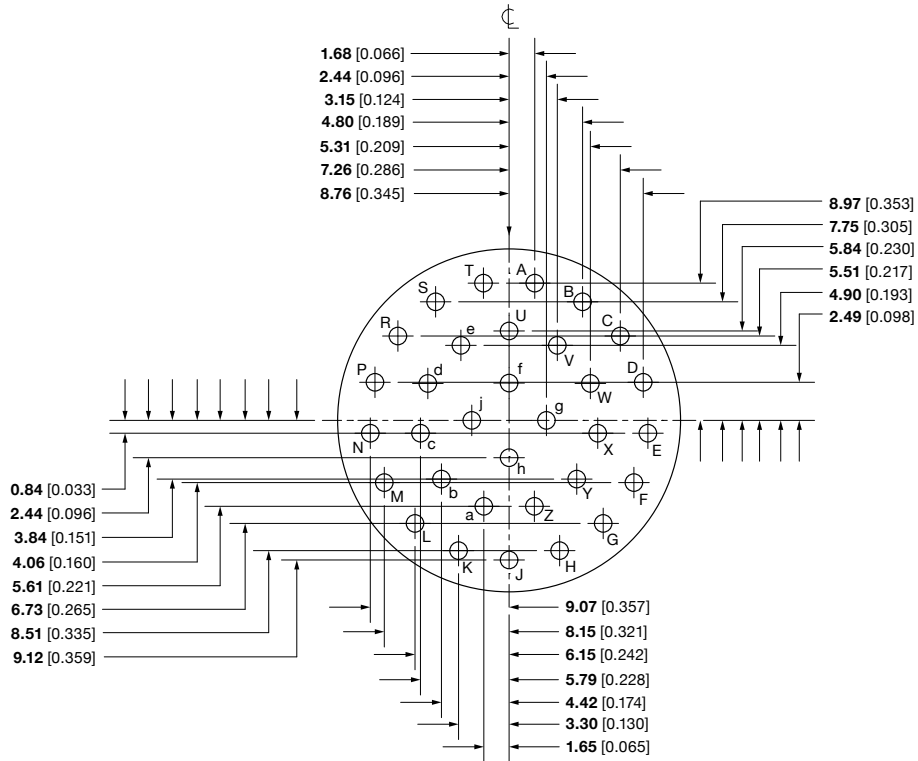

19-35/19-66

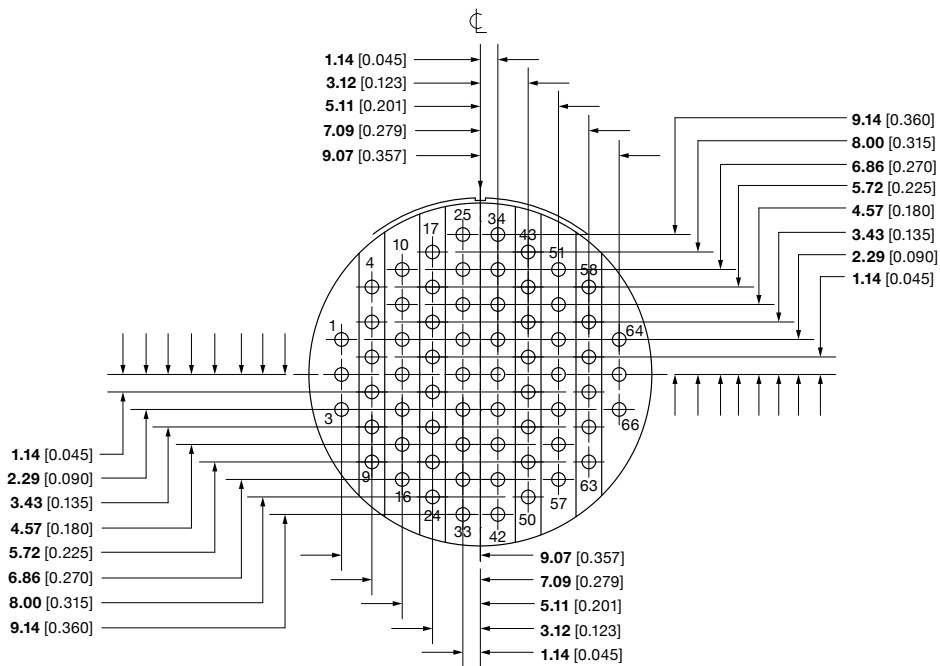



19-45

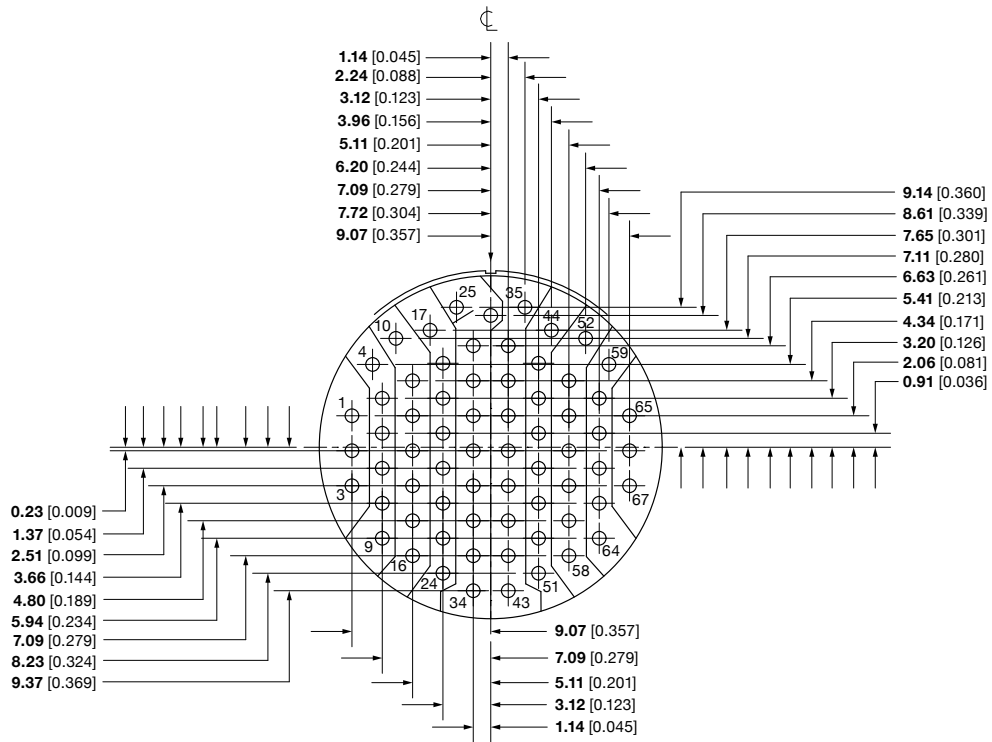

21-11

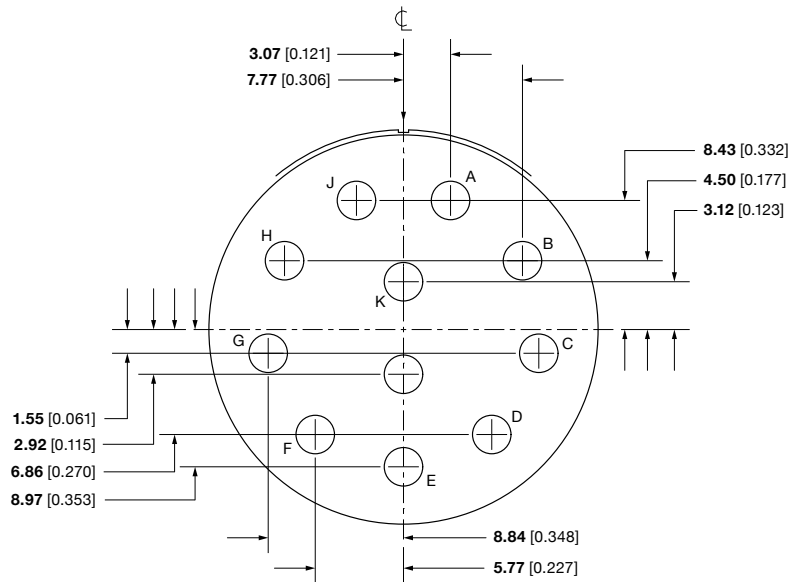



21-16

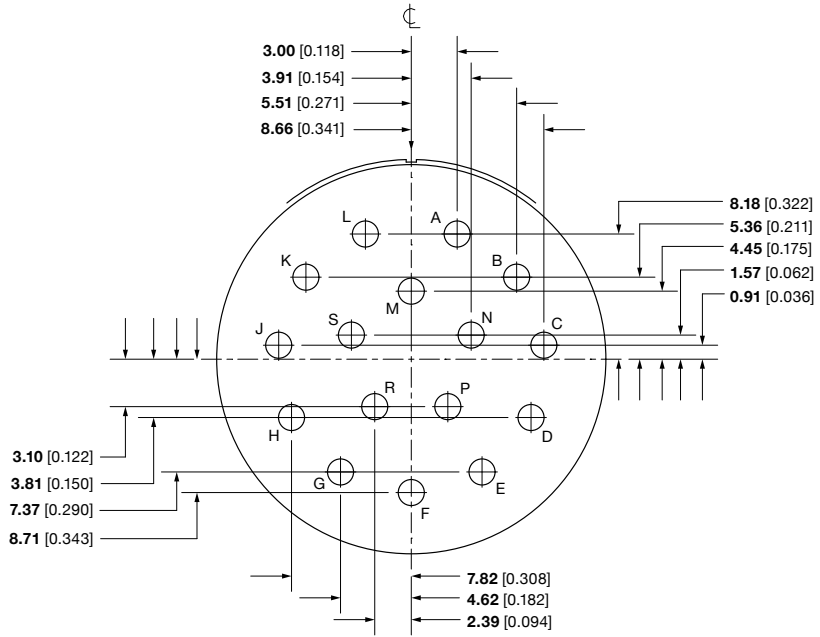

21-24

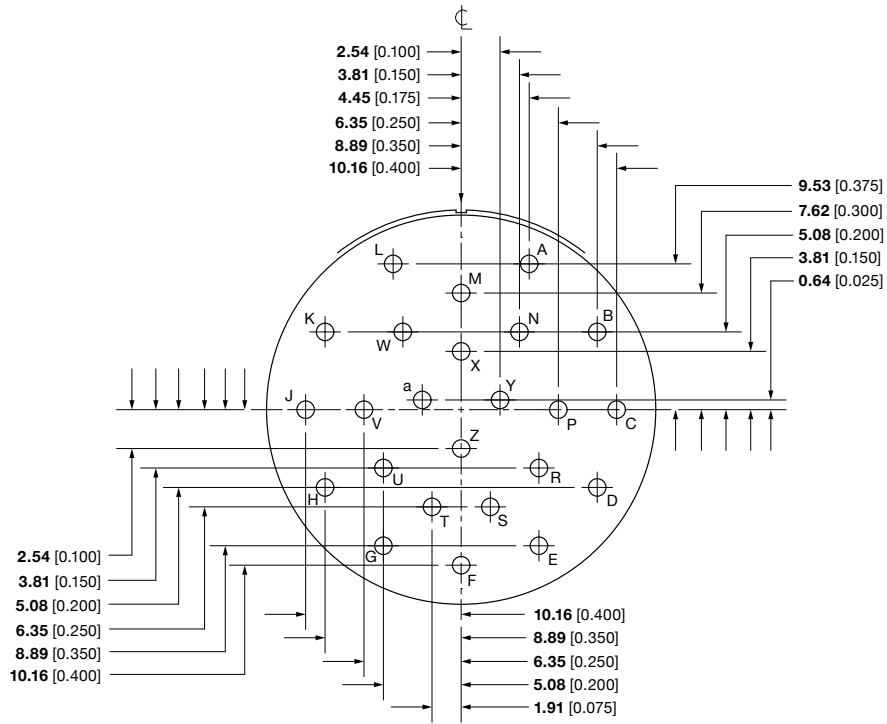

N/A



21-25

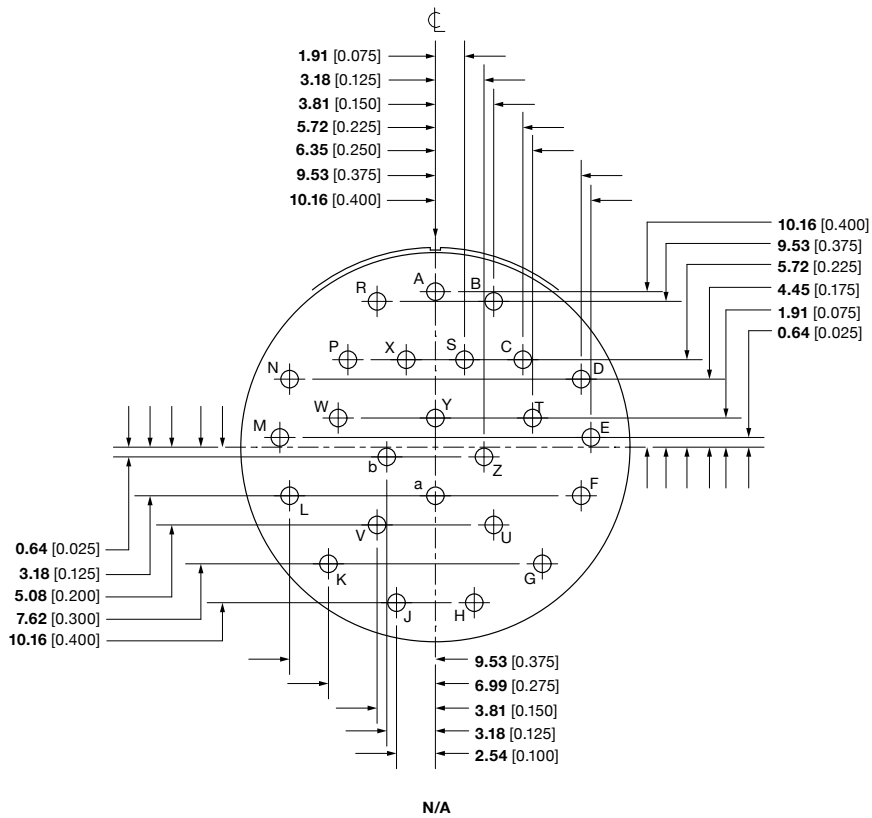

21-27

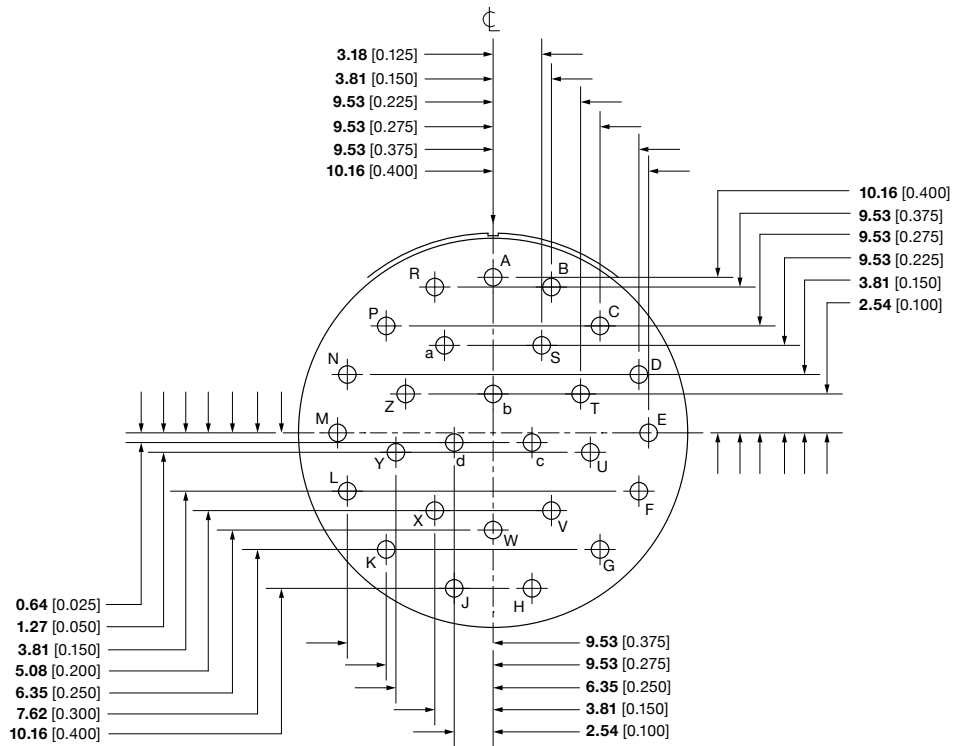



21-01/21-35

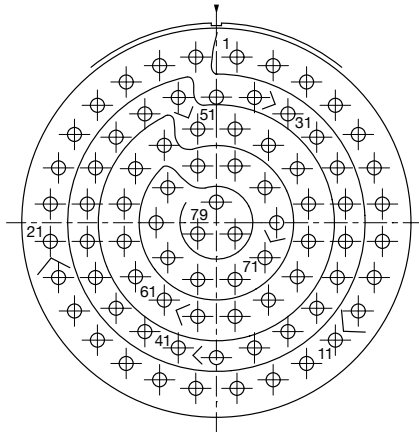

Contact Position	Location	
	X Axis	Y Axis
1	+0.053	+0.426
2	+0.146	+0.404
3	+0.232	+0.362
4	+0.306	+0.302
5	+0.365	+0.227
6	+0.406	+0.141
7	+0.427	+0.048
8	+0.427	-0.048
9	+0.406	-0.141
10	+0.365	-0.227
11	+0.306	-0.302
12	+0.232	-0.362
13	+0.146	-0.404
14	+0.053	-0.426
15	-0.053	-0.426
16	-0.146	-0.404
17	-0.232	-0.362
18	-0.306	-0.302
19	-0.365	-0.227
20	-0.406	-0.141
21	-0.427	-0.048
22	-0.427	+0.048
23	-0.406	+0.141
24	-0.365	+0.227
25	-0.306	+0.302
26	-0.232	+0.362
27	-0.146	+0.404

Contact Position	Location	
	X Axis	Y Axis
28	-0.053	+0.426
29	+0.000	+0.323
30	+0.098	+0.322
31	+0.184	+0.280
32	+0.258	+0.220
33	+0.311	+0.141
34	+0.332	+0.048
35	+0.332	-0.048
36	+0.311	-0.141
37	+0.258	-0.220
38	+0.184	-0.280
39	+0.098	-0.322
40	+0.000	-0.347
41	-0.098	-0.322
42	-0.184	-0.280
43	-0.258	-0.220
44	-0.311	-0.141
45	-0.332	-0.048
46	-0.332	+0.048
47	-0.311	+0.141
48	-0.258	+0.220
49	-0.184	+0.280
50	-0.098	+0.322
51	-0.048	+0.241
52	+0.048	+0.241
53	+0.134	+0.199
54	+0.208	+0.139

Contact Position	Location	
	X Axis	Y Axis
55	+0.237	+0.048
56	+0.237	-0.048
57	+0.208	-0.139
58	+0.134	-0.199
59	+0.048	-0.241
60	-0.048	-0.241
61	-0.134	-0.199
62	-0.208	-0.139
63	-0.237	-0.048
64	-0.237	+0.048
65	-0.208	+0.139
66	-0.134	+0.199
67	-0.048	+0.146
68	+0.048	+0.146
69	+0.125	+0.090
70	+0.155	+0.000
71	+0.125	-0.090
72	+0.048	-0.146
73	-0.048	-0.146
74	-0.125	-0.090
75	-0.155	-0.000
76	-0.125	+0.090
77	+0.000	+0.053
78	+0.048	-0.029
79	-0.048	-0.029
—	—	—



21-39

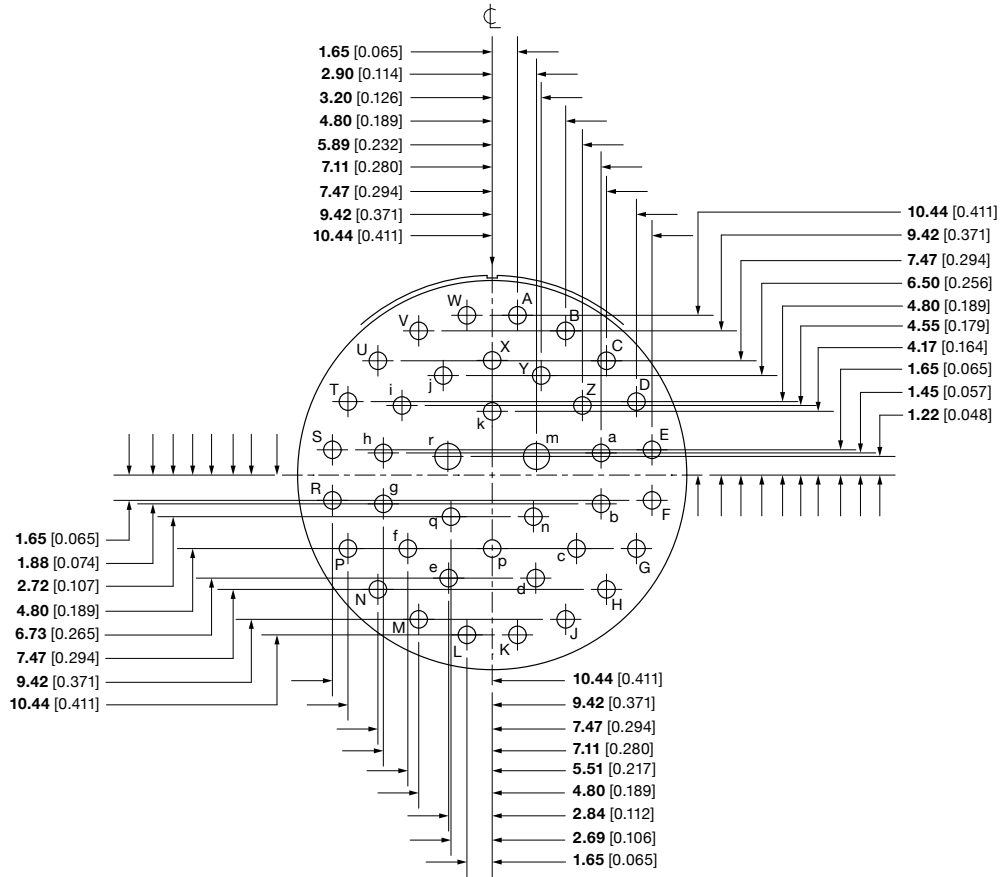

21-41

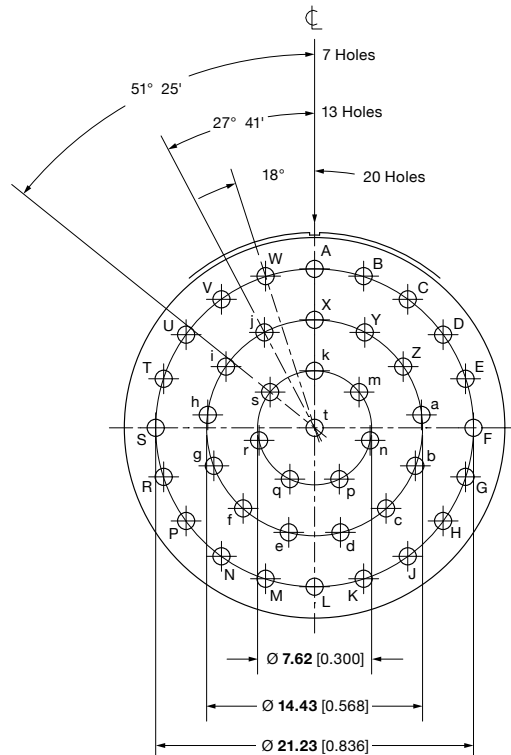



23-21

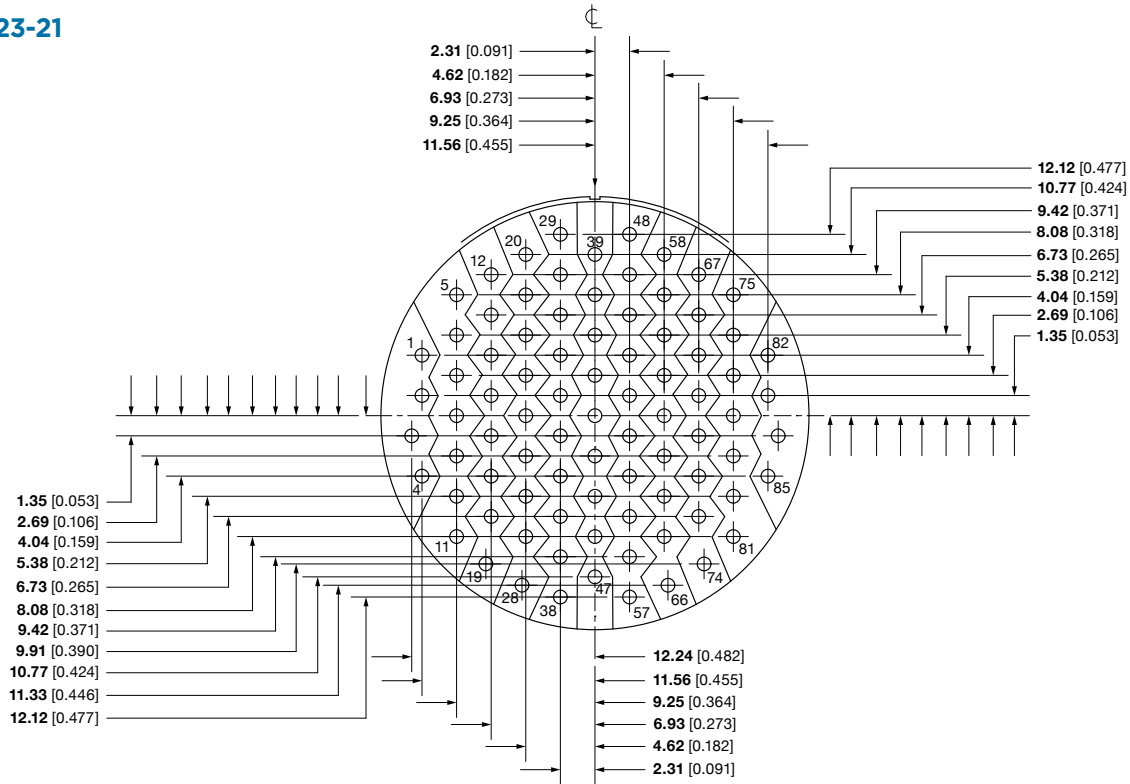

23-21

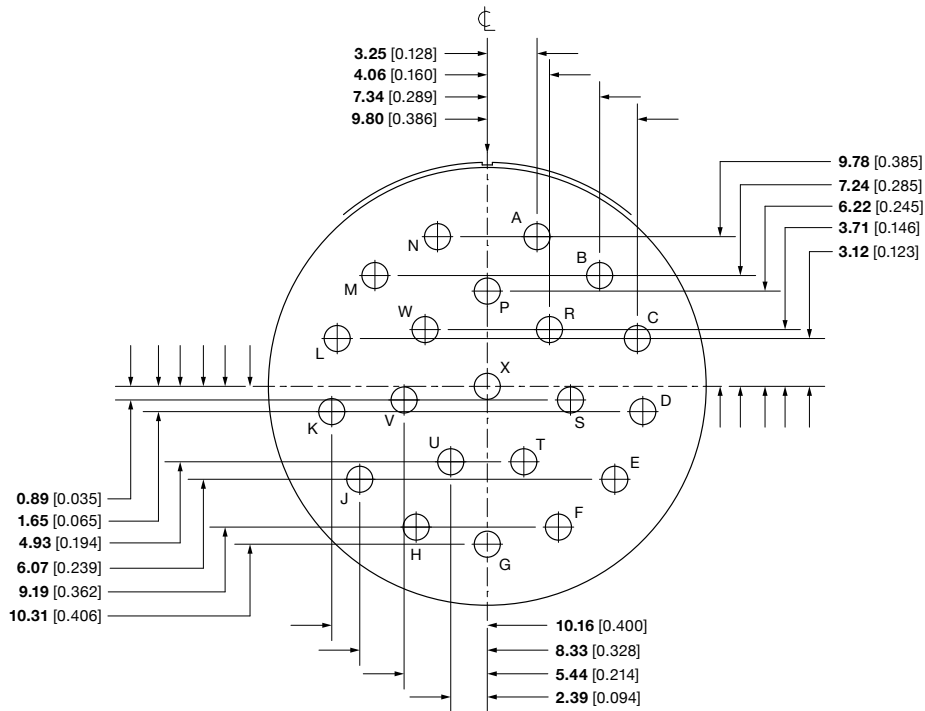



23-32

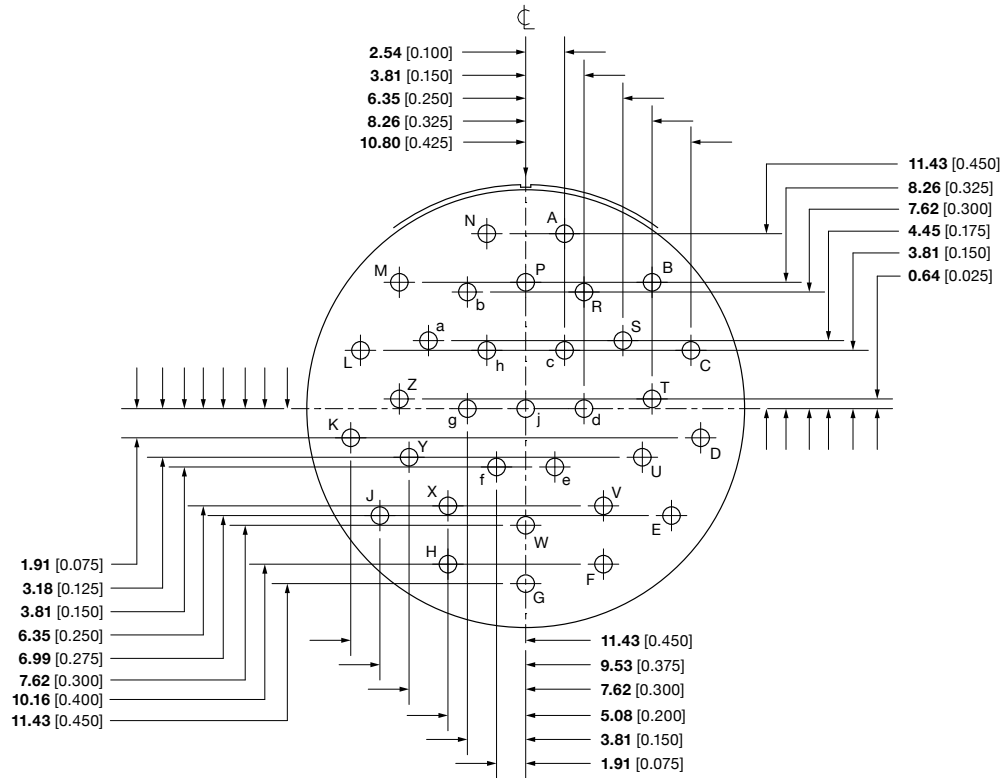

23-34

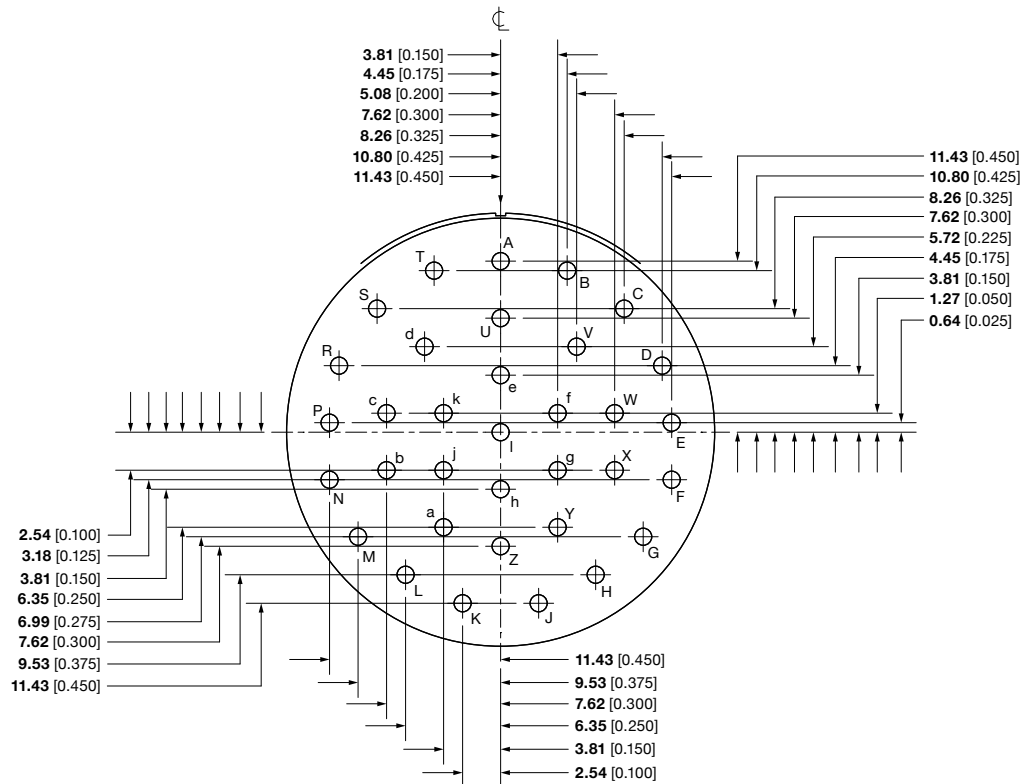



23-01/23-35

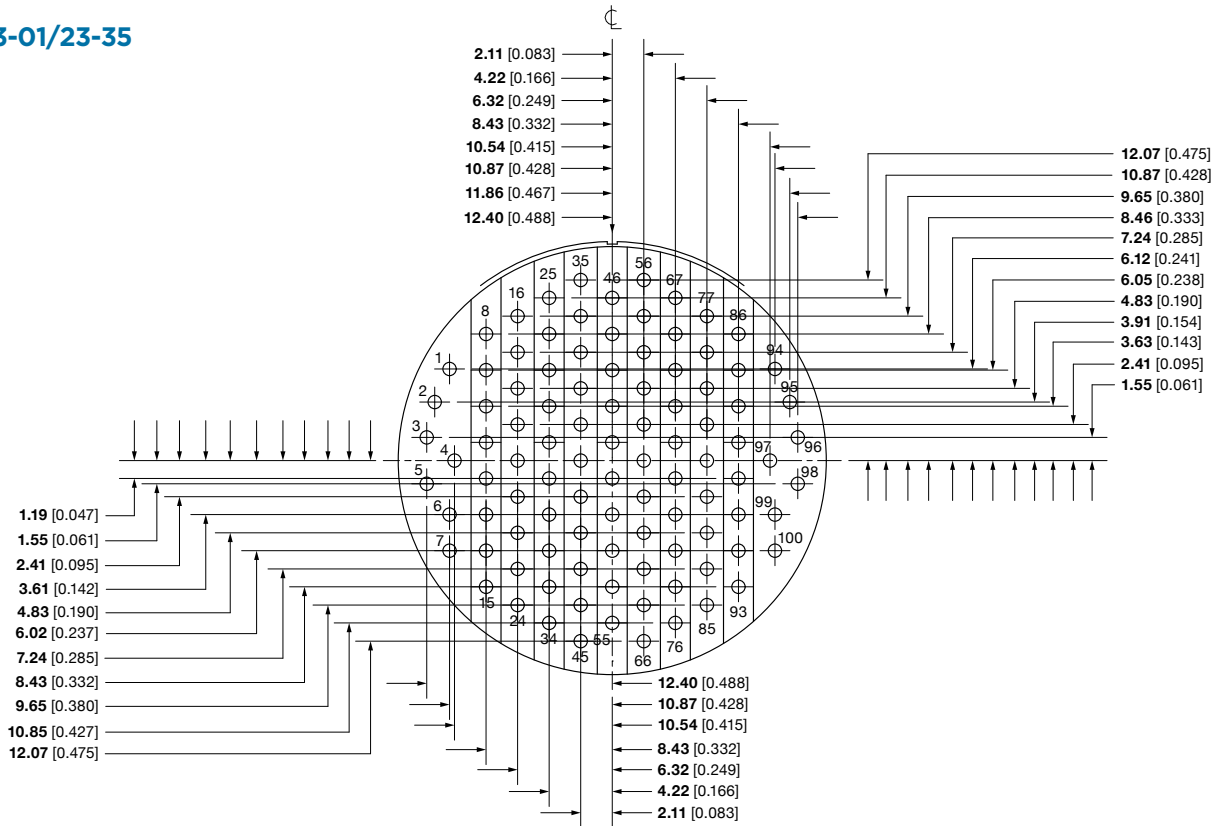

23-36

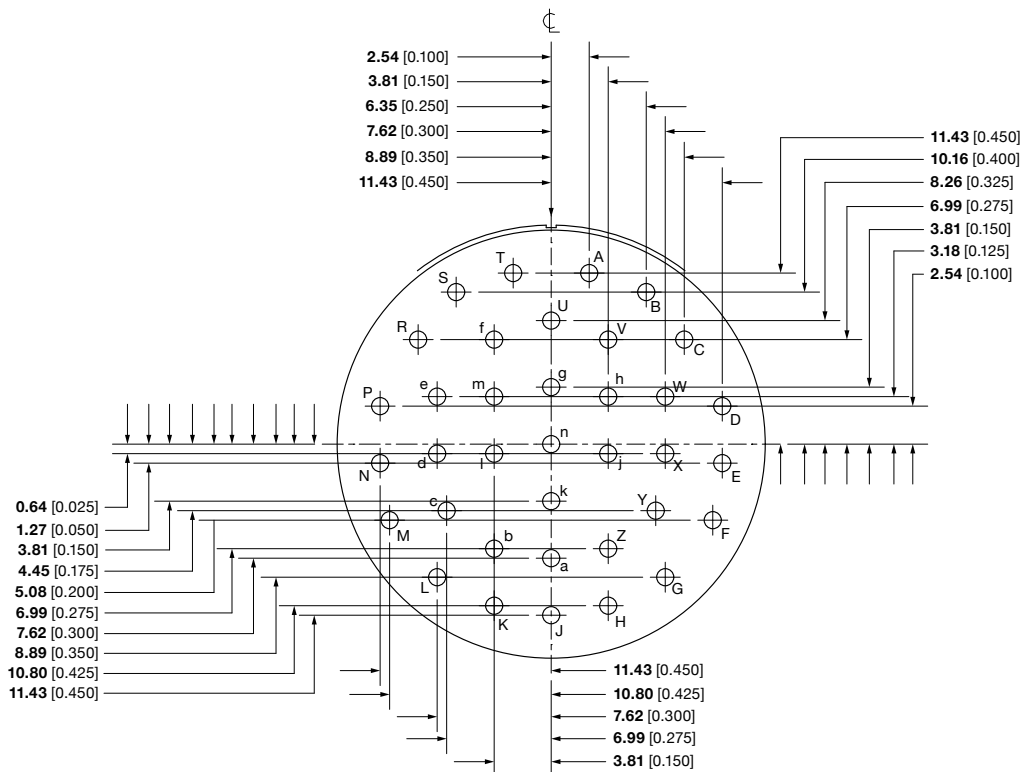



23-53

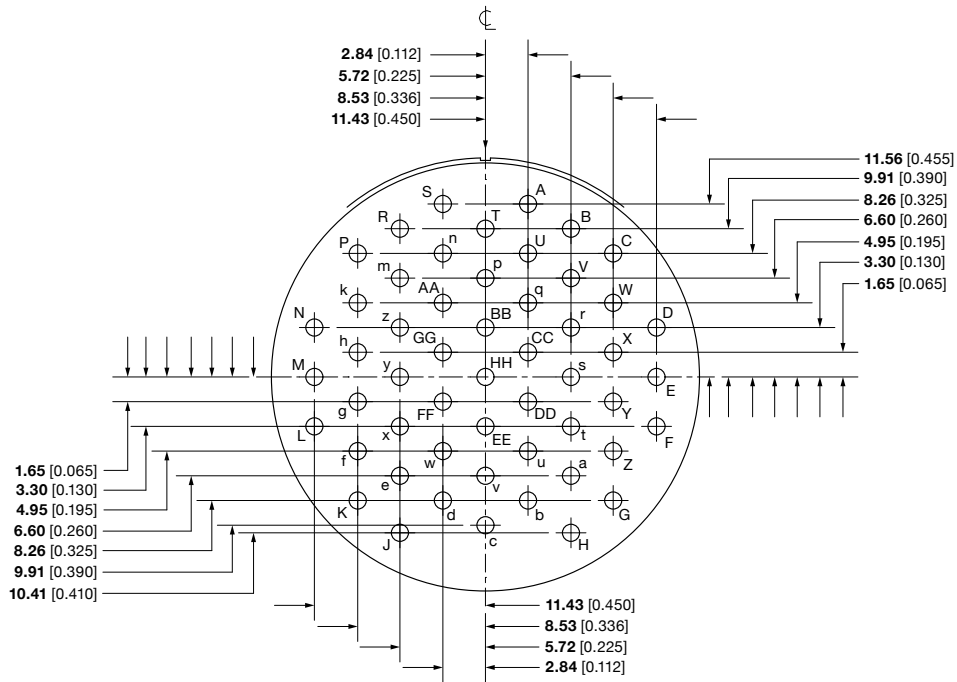

23-55

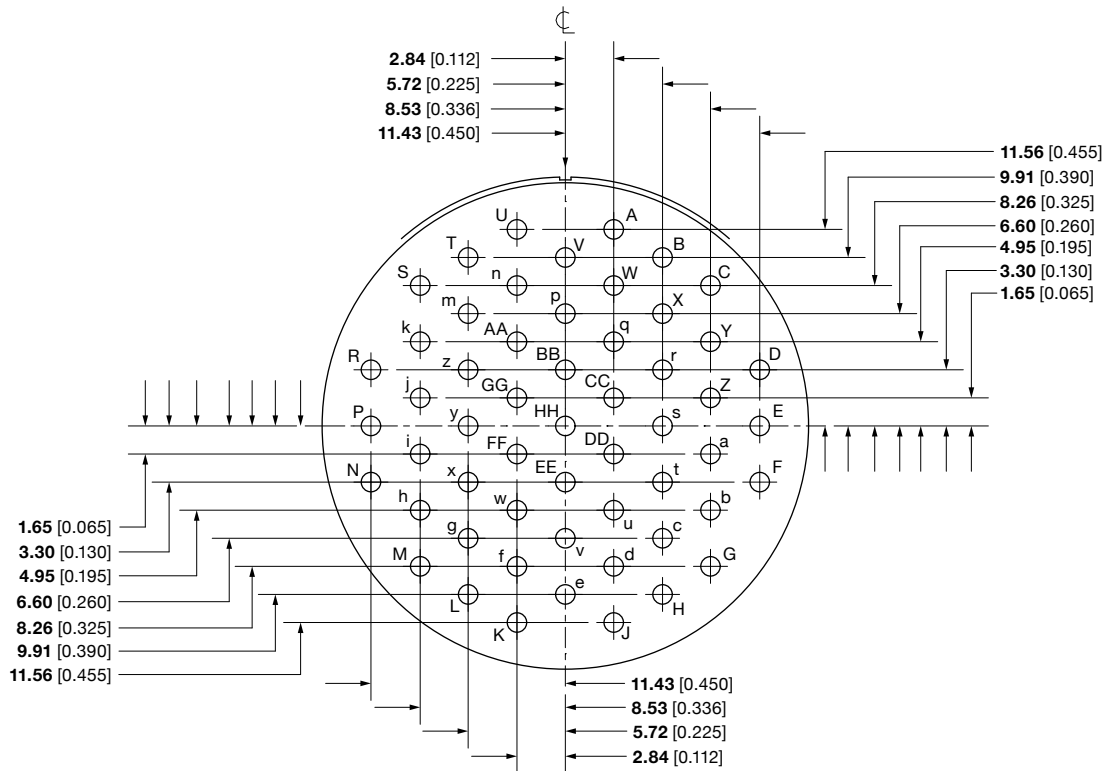



23-97

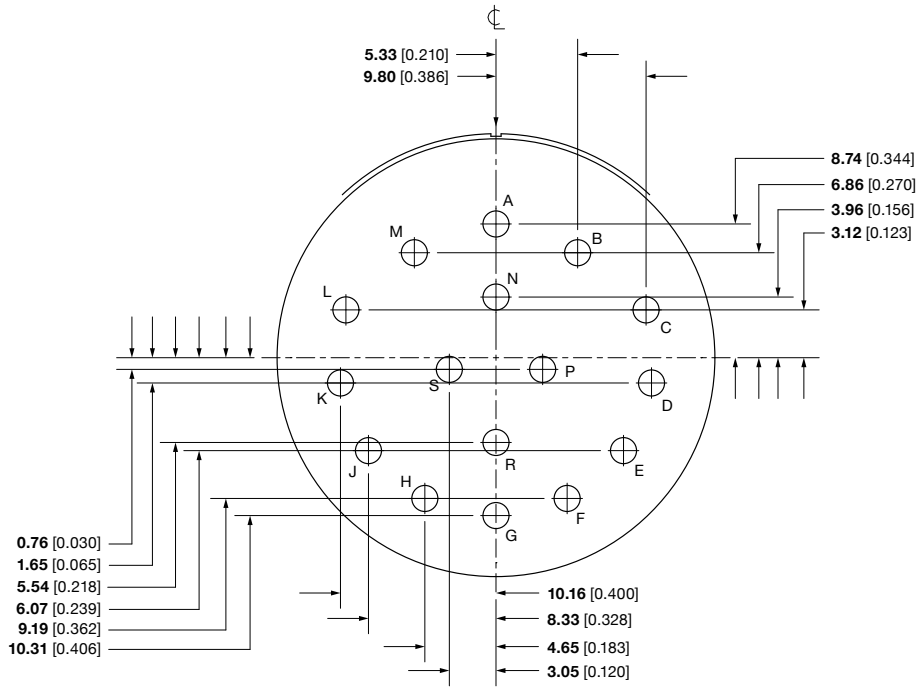

23-99

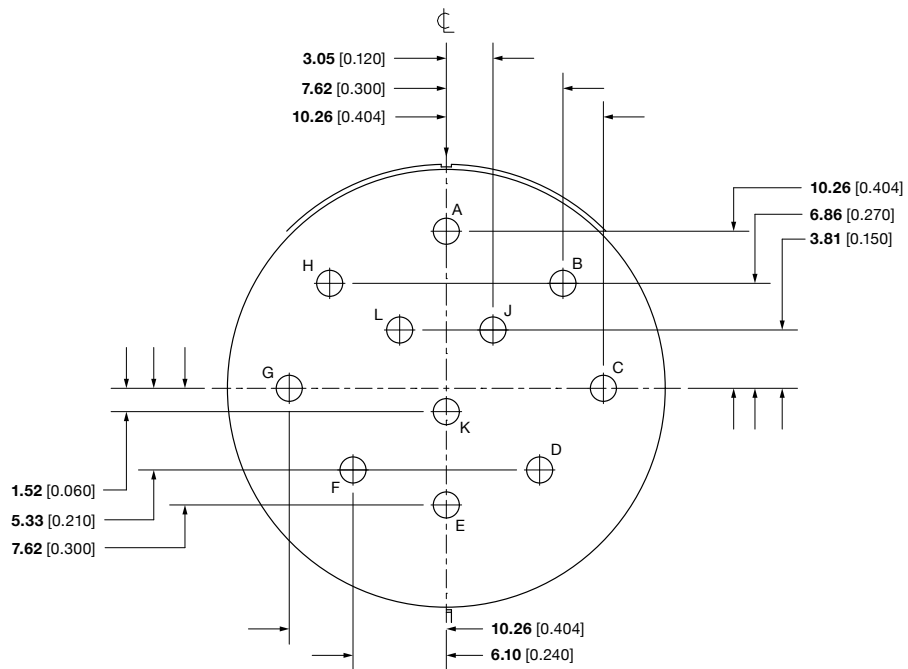



25-02

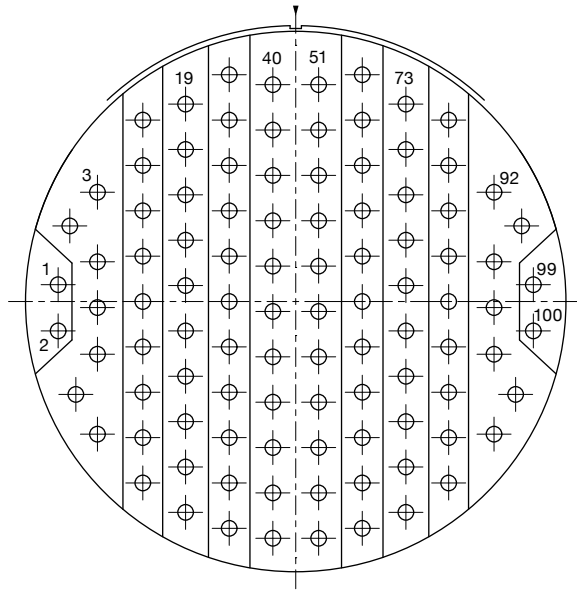



Contact Position	Location	
	X Axis	Y Axis
1	-0.550	+0.039
2	-0.550	-0.068
3	-0.459	+0.253
4	-0.523	+0.175
5	-0.459	+0.092
6	-0.459	-0.014
7	-0.459	-0.122
8	-0.509	-0.215
9	-0.459	-0.307
10	-0.354	+0.420
11	-0.354	+0.315
12	-0.354	+0.210
13	-0.354	+0.105
14	-0.354	+0.000
15	-0.354	-0.105
16	-0.354	-0.210
17	-0.354	-0.315
18	-0.354	-0.420
19	-0.255	+0.457
20	-0.255	+0.352
21	-0.255	+0.247
22	-0.255	+0.142
23	-0.255	+0.037
24	-0.255	-0.068
25	-0.255	-0.173
26	-0.255	-0.278
27	-0.255	-0.383
28	-0.255	-0.488
29	-0.154	+0.525
30	-0.154	+0.420
31	-0.154	+0.315
32	-0.154	+0.210
33	-0.154	+0.105
34	-0.154	+0.000

Contact Position	Location	
	X Axis	Y Axis
35	-0.154	-0.105
36	-0.154	-0.210
37	-0.154	-0.315
38	-0.154	-0.420
39	-0.154	-0.525
40	-0.053	+0.502
41	-0.053	+0.397
42	-0.053	+0.292
43	-0.053	+0.187
44	-0.053	+0.082
45	-0.053	-0.023
46	-0.053	-0.128
47	-0.053	-0.233
48	-0.053	-0.338
49	-0.053	-0.443
50	-0.053	-0.548
51	+0.053	+0.502
52	+0.053	+0.397
53	+0.053	+0.292
54	+0.053	+0.187
55	+0.053	+0.082
56	+0.053	-0.023
57	+0.053	-0.128
58	+0.053	-0.233
59	+0.053	-0.338
60	+0.053	-0.443
61	+0.053	-0.548
62	+0.154	+0.525
63	+0.154	+0.420
64	+0.154	+0.315
65	+0.154	+0.210
66	+0.154	+0.105
67	+0.154	+0.000
68	+0.154	-0.105

Contact Position	Location	
	X Axis	Y Axis
69	+0.154	-0.210
70	+0.154	-0.315
71	+0.154	-0.420
72	+0.154	-0.525
73	+0.255	+0.457
74	+0.255	+0.352
75	+0.255	+0.247
76	+0.255	+0.142
77	+0.255	+0.037
78	+0.255	-0.068
79	+0.255	-0.173
80	+0.255	-0.278
81	+0.255	-0.383
82	+0.255	-0.488
83	+0.354	+0.420
84	+0.354	+0.315
85	+0.354	+0.210
86	+0.354	+0.105
87	+0.354	+0.000
88	+0.354	-0.105
89	+0.354	-0.210
90	+0.354	-0.315
91	+0.354	-0.420
92	+0.459	+0.253
93	+0.523	+0.175
94	+0.459	+0.092
95	+0.459	-0.014
96	+0.459	-0.122
97	+0.509	-0.215
98	+0.459	-0.037
99	+0.550	+0.039
100	+0.550	-0.068



25-04

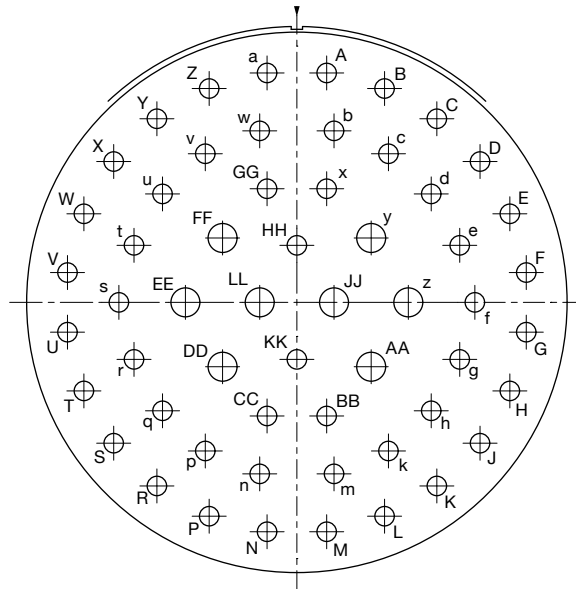

Contact Position	Location	
	X Axis	Y Axis
A	+0.069	+0.531
B	+0.203	+0.495
C	+0.324	+0.425
D	+0.424	+0.326
E	+0.493	+0.205
F	+0.531	+0.069
G	+0.531	-0.069
H	+0.493	-0.205
J	+0.424	-0.326
K	+0.324	-0.425
L	+0.203	-0.495
M	+0.069	-0.531
N	-0.069	-0.531
P	-0.203	-0.495
R	-0.324	-0.425
S	-0.424	-0.326
T	-0.493	-0.205
U	-0.531	-0.069
V	-0.531	+0.069

Contact Position	Location	
	X Axis	Y Axis
W	-0.493	+0.205
X	-0.424	+0.326
Y	-0.324	+0.425
Z	-0.203	+0.495
a	-0.069	+0.531
b	+0.806	+0.397
c	+0.212	+0.344
d	+0.311	+0.251
e	+0.377	+0.132
f	+0.412	+0.000
g	+0.377	-0.132
h	+0.311	-0.251
k	+0.212	-0.344
m	+0.086	-0.397
n	-0.086	-0.397
p	-0.212	-0.344
q	-0.311	-0.251
r	-0.377	-0.132
s	-0.412	+0.000

Contact Position	Location	
	X Axis	Y Axis
t	-0.377	+0.132
u	-0.311	+0.251
v	-0.212	+0.344
w	-0.086	+0.397
x	+0.069	+0.263
y	+0.172	+0.149
z	+0.258	+0.000
AA	+0.172	-0.149
BB	+0.069	-0.263
CC	-0.069	-0.263
DD	-0.172	-0.149
EE	-0.258	+0.000
FF	-0.172	+0.149
GG	-0.069	+0.263
HH	+0.000	+0.132
JJ	+0.086	+0.000
KK	+0.000	-0.132
LL	-0.086	+0.000



25-19

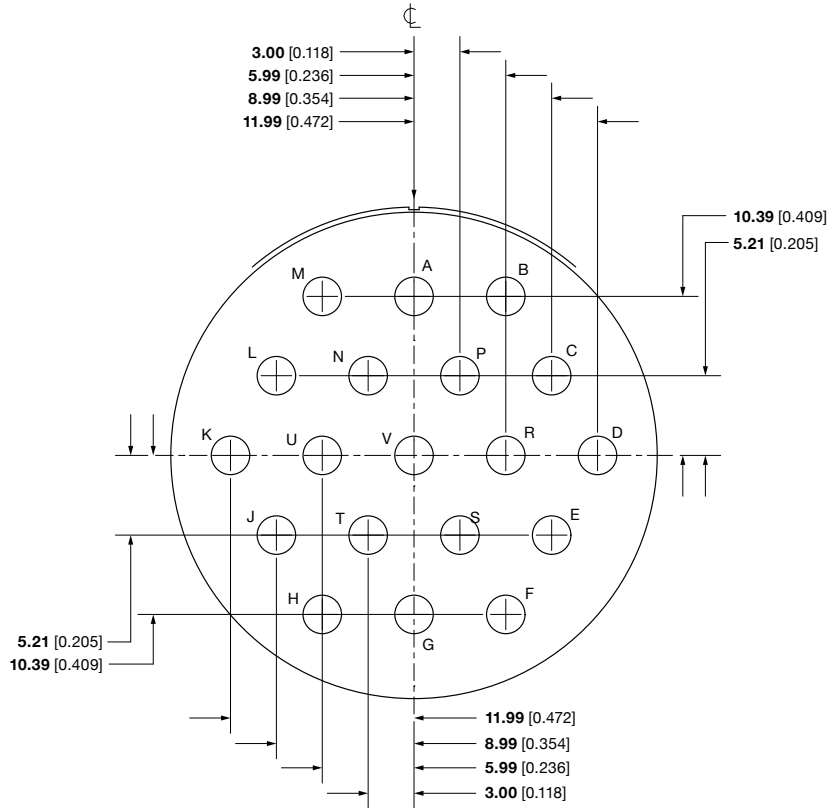

25-24

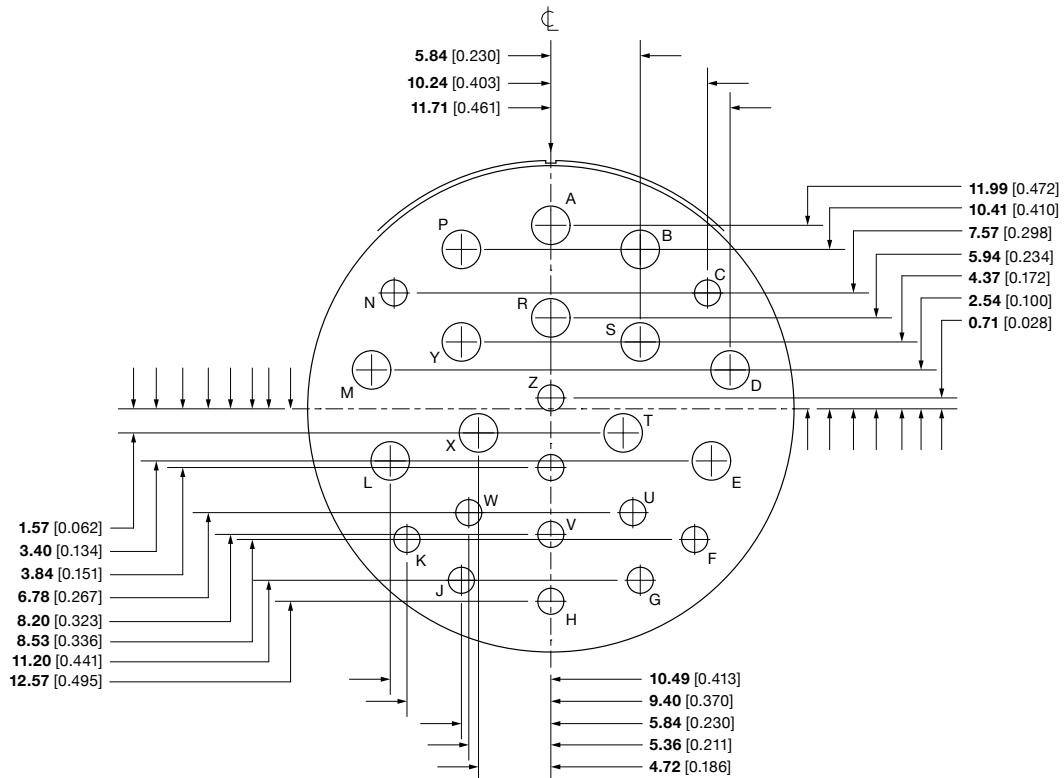



25-29

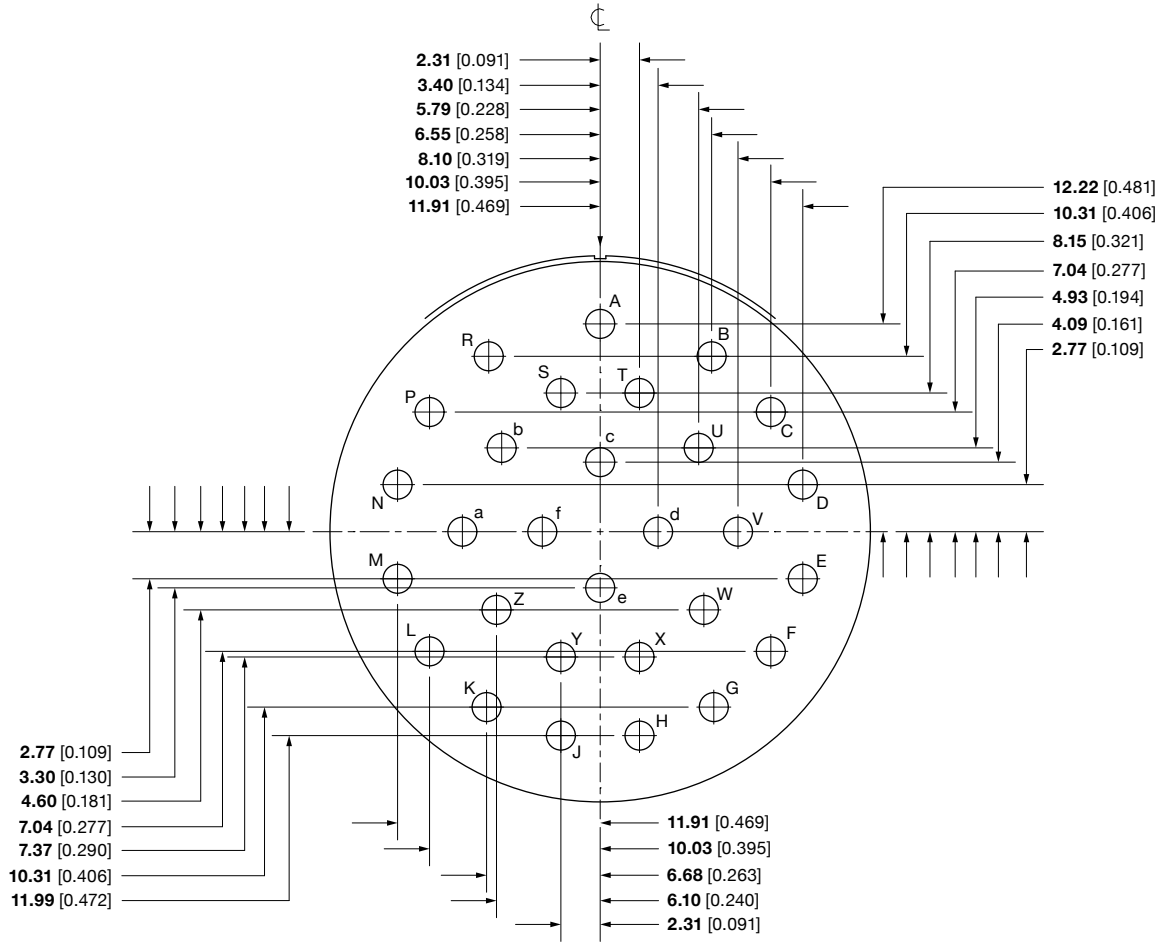



25-01, 25-35

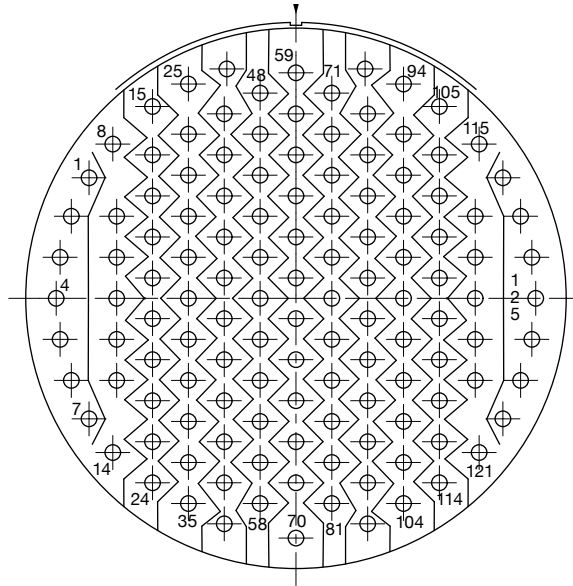

Contact Position	Location	
	X Axis	Y Axis
1	-0.479	+0.279
2	-0.520	+0.190
3	-0.546	+0.095
4	-0.555	+0.000
5	-0.546	-0.095
6	-0.520	-0.190
7	-0.479	-0.279
8	-0.424	+0.357
9	-0.415	+0.190
10	-0.415	+0.095

Contact Position	Location	
	X Axis	Y Axis
11	-0.415	+0.000
12	-0.415	-0.095
13	-0.415	-0.190
14	-0.424	-0.357
15	-0.332	+0.444
16	-0.332	+0.332
17	-0.332	-0.237
18	-0.332	+0.142
19	-0.332	+0.047
20	-0.332	-0.047

Contact Position	Location	
	X Axis	Y Axis
21	-0.332	-0.142
22	-0.332	-0.237
23	-0.332	-0.332
24	-0.332	-0.427
25	-0.249	+0.496
26	-0.249	+0.380
27	-0.249	+0.285
28	-0.249	+0.190
29	-0.249	+0.095
30	-0.249	+0.000



Contact Position	Location	
	X Axis	Y Axis
31	-0.249	-0.095
32	-0.249	-0.190
33	-0.249	-0.285
34	-0.249	-0.380
35	-0.249	-0.475
36	-0.160	+0.531
37	-0.166	+0.427
38	-0.166	+0.332
39	-0.166	+0.237
40	-0.166	+0.142
41	-0.166	+0.047
42	-0.166	-0.047
43	-0.166	-0.142
44	-0.166	-0.237
45	-0.166	-0.332
46	-0.166	-0.427
47	-0.166	-0.522
48	-0.083	+0.475
49	-0.083	+0.380
50	-0.083	+0.285
51	-0.083	+0.190
52	-0.083	+0.095
53	-0.083	+0.000
54	-0.083	-0.095
55	-0.083	-0.190
56	-0.083	-0.285
57	-0.083	-0.380
58	-0.083	-0.475
59	+0.000	+0.522
60	+0.000	+0.427
61	+0.000	+0.332
62	+0.000	+0.237
63	+0.000	+0.142

Contact Position	Location	
	X Axis	Y Axis
64	+0.000	+0.047
65	+0.000	-0.047
66	+0.000	-0.142
67	+0.000	-0.237
68	+0.000	-0.332
69	+0.000	-0.427
70	+0.000	-0.555
71	+0.083	+0.475
72	+0.083	+0.380
73	+0.083	+0.285
74	+0.083	+0.190
75	+0.083	+0.095
76	+0.083	+0.000
77	+0.083	-0.095
78	+0.083	-0.190
79	+0.083	-0.285
80	+0.083	-0.380
81	+0.083	-0.475
82	+0.160	+0.531
83	+0.166	+0.427
84	+0.166	+0.332
85	+0.166	+0.237
86	+0.166	+0.142
87	+0.166	+0.047
88	+0.166	-0.047
89	+0.166	-0.142
90	+0.166	-0.237
91	+0.166	-0.332
92	+0.166	-0.427
93	+0.249	-0.522
94	+0.249	+0.496
95	+0.249	+0.380
96	+0.249	+0.285

Contact Position	Location	
	X Axis	Y Axis
97	+0.249	+0.190
98	+0.249	+0.095
99	+0.249	+0.000
100	+0.249	-0.095
101	+0.249	-0.190
102	+0.249	-0.285
103	+0.249	-0.380
104	+0.249	-0.475
105	+0.332	+0.444
106	-0.232	+0.332
107	-0.232	+0.237
108	-0.232	+0.142
109	-0.232	+0.047
110	-0.232	-0.047
111	-0.232	-0.142
112	-0.232	-0.237
113	-0.232	-0.332
114	-0.232	-0.427
115	+0.424	+0.357
116	+0.415	+0.190
117	+0.415	+0.095
118	+0.415	+0.000
119	+0.415	-0.095
120	+0.415	-0.190
121	+0.424	-0.357
122	+0.479	+0.279
123	+0.520	+0.190
124	+0.546	+0.095
125	+0.555	+0.000
126	+0.546	-0.095
127	+0.520	-0.190
128	+0.479	-0.279



25-37

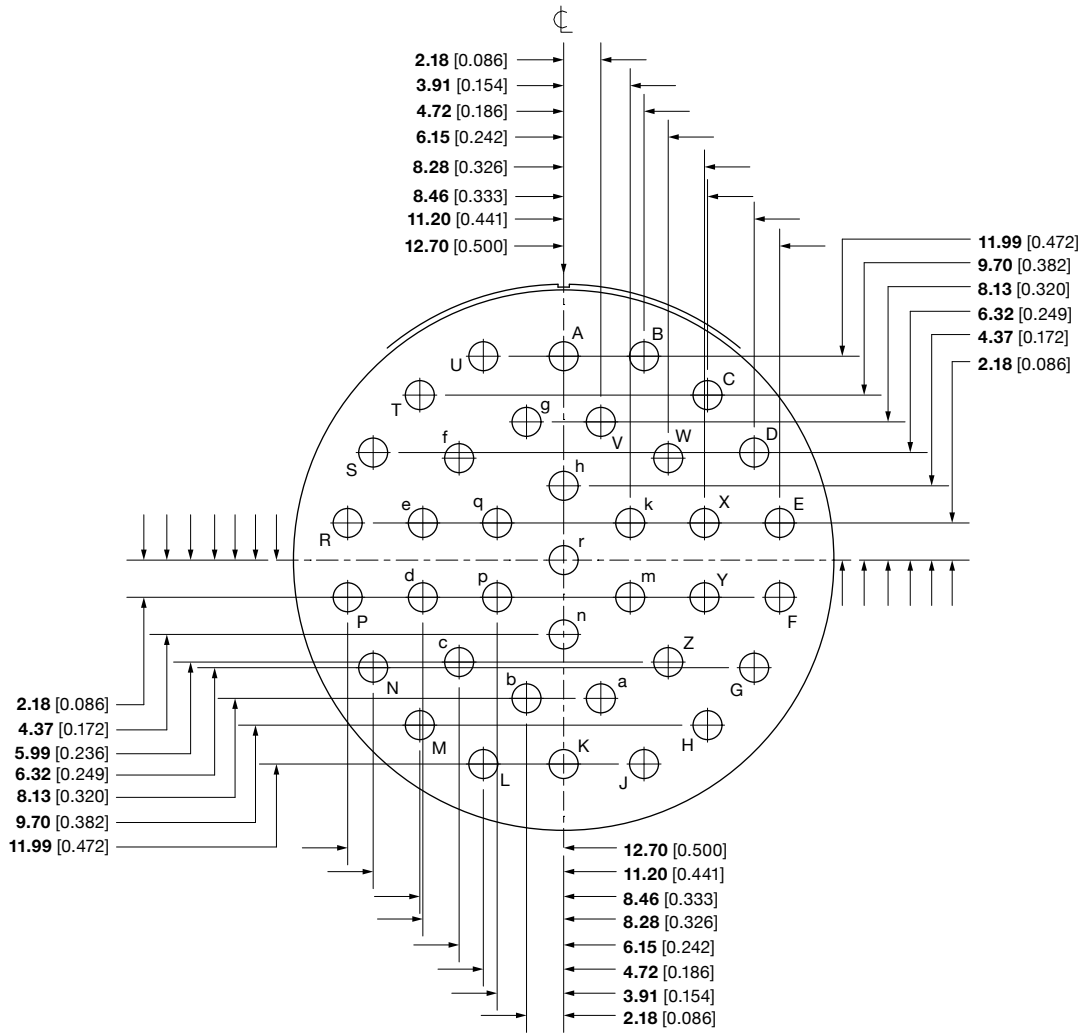



25-43

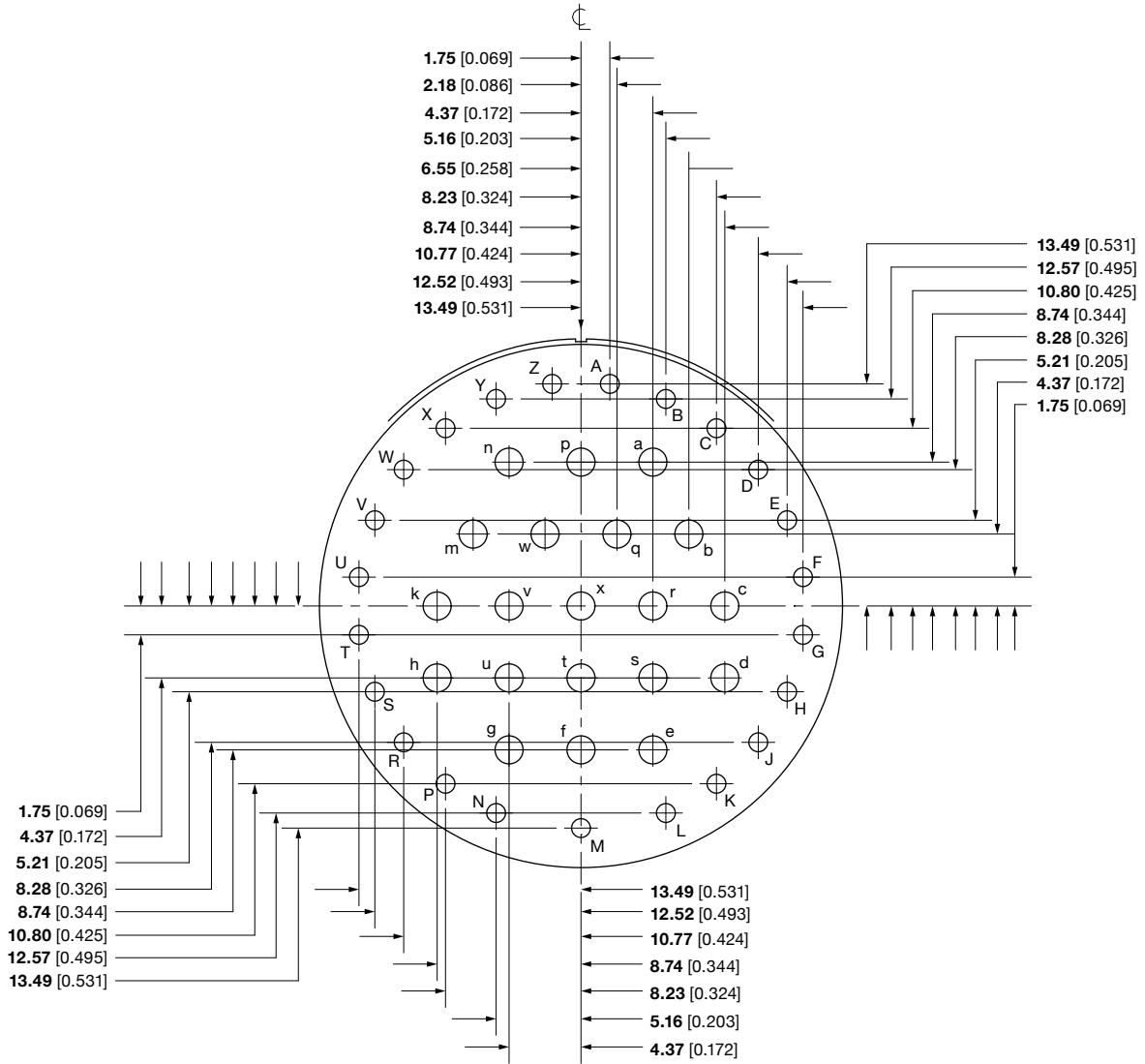



25-61

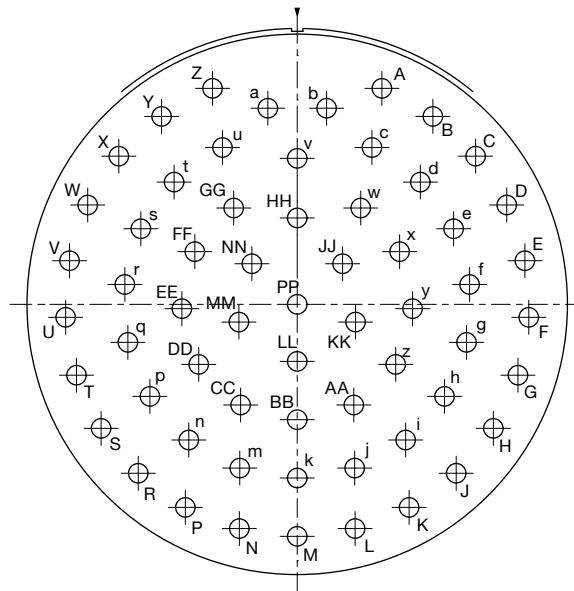

Contact Position	Location	
	X Axis	Y Axis
A	+0.196	+0.500
B	+0.314	+0.435
C	+0.413	+0.343
D	+0.485	+0.230
E	+0.527	+0.101
F	+0.536	-0.030
G	+0.511	-0.164
H	+0.454	-0.287
J	+0.368	-0.391
K	+0.259	-0.470
L	+0.134	-0.519
M	+0.000	-0.537
N	-0.134	-0.519
P	-0.259	-0.470
R	-0.368	-0.391
S	-0.454	-0.287
T	-0.511	-0.164
U	-0.536	-0.030
V	-0.527	+0.101
W	-0.485	+0.230
X	-0.413	+0.343

Contact Position	Location	
	X Axis	Y Axis
Y	-0.314	+0.435
Z	-0.196	+0.500
a	-0.068	+0.454
b	+0.068	+0.454
c	+0.173	+0.363
d	+0.285	+0.283
e	+0.362	+0.175
f	+0.399	+0.046
g	+0.392	-0.088
h	+0.341	-0.213
i	+0.251	-0.314
j	+0.133	-0.379
k	+0.000	-0.402
m	-0.133	-0.379
n	-0.251	-0.314
p	-0.341	-0.213
q	-0.392	-0.088
r	-0.399	+0.046
s	-0.362	+0.175
t	-0.285	+0.283
u	-0.173	+0.363

Contact Position	Location	
	X Axis	Y Axis
v	+0.000	+0.338
w	+0.147	+0.223
x	+0.237	+0.122
y	+0.267	-0.010
z	+0.228	-0.139
AA	+0.131	-0.233
BB	+0.000	-0.267
CC	-0.131	-0.233
DD	-0.228	-0.139
EE	-0.267	-0.010
FF	-0.237	+0.122
GG	-0.147	+0.223
HH	+0.000	+0.200
JJ	+0.105	+0.094
KK	+0.135	-0.041
LL	+0.000	-0.132
MM	-0.135	-0.041
NN	-0.105	+0.094
PP	+0.000	+0.000
—	—	—

**ROBUST**

- Marine bronze shell
- Excellent corrosion resistance
- -65°C to +175°C operating temperature range
- Excellent EMI protection

RELIABLE

- 100% scoop proof
- Self locking threaded coupling

COMPLIANT

- STD CECC 75201-002
- RoHS compliant

VERSATILE

- Available in 9 shell sizes
- Single hole mounting
- Environmentally sealed

APPLICATIONS

- Shipboard
- Ground vehicles

DTS-B Series Bronze Connectors**38999 Series III-Style Connectors**

DEUTSCH DTS-B threaded connectors are MIL-DTL-38999 Series III and STD CECC 75201-002 styles, but feature a bronze shell with a scoop-proof design, and environmental sealing to help withstand harsh marine environments.

Marine bronze offers excellent corrosion protection. The shell material is robust and inherently resists corrosion, eliminating the need for plating that can wear to expose base materials.

The DEUTSCH DTS-B Series subminiature circular connectors offer a scoop-proof design for easy, reliable mating and a threaded coupling for excellent vibration resistance. Available in nine shell sizes, the connector's arrangements, contacts and tools all conform to standard MIL-DTL 38999 Series III. Excellent corrosion resistance makes them well suited to most marine and military ground vehicle applications.



DTS-B Bronze Connectors

38999 Series III-Style Connectors

Specifications

MATERIALS

- **Shell:** Marine bronze
- **Insert:** Thermoplastic and fluorinated silicone elastomer
- **EMI Spring Fingers:** Nickel or cadmium-plated beryllium copper
- **O-Ring:** Fluorinated silicone elastomer

ENVIRONMENTAL

- **Temperature Range:** -65°C to +175°C
- **Fluid Resistance:** Fluid immersion per EIA 364.10, including resistance to
MIL-PRF-5606: Hydraulic fluid
MIL-DTL-83133: JP-8 aviation fuel
MIL-PRF-7808: Lubricating oil
MIL-PRF-23699: Lubricating oil
MIL-A-8243: Deicing/defrosting fluid
MIL-C-25769: Aircraft cleaning compound
MIL-PRF-87937: Aircraft cleaning compound
MIL-G-3056: Gasoline
- **Salt Spray:** 500 hours
- **Thermal Cycling:** per MIL-STD-1344 method 1001 test B

MECHANICAL

- **Sine Vibration:** Up to 60 g for 36 hr.
- **Random Vibration:** Up to 41.7 g for 16 hr. at 175° C
Up to 50 g for 16 hr. at ambient temperature
- **Shock:** 300 g, 3 ms in the 3 axes
- **Durability:** 500 mating cycles
- **Contact Retention:**
Size 23: 44 N (10 lb.)
Size 22D: 44 N (10 lb.)
Size 20: 67 N (15 lb.)
Size 16: 111 N (25 lb.)
Size 12: 111 N (25 lb.)
Size 8: 111 N (25 lb.)

ELECTRICAL

- **Shell-to-Shell Conductivity:** 2.5 mV max.
- **Shielding Effectiveness:** >90 dB at 100 MHz, >65 dB through 10 GHz



DTS-B Bronze Connectors

38999 Series III-Style Connectors

Voltage Rating

Service Rating	Suggested Operating Voltage		Test Voltage at Altitude (VAC _{rms})			
	VAC _{rms}	VDC	Sea Level	50,000 Ft.	70,000 Ft.	100,000 Ft.
M	400	550	1300	550	350	200
N	300	450	1000	400	260	200
I	600	850	1800	600	400	200
II	750	1050	2300	800	500	200

Current Rating

Contact Size	Test Current (A)	Voltage Drop (mV)
23	5	73
22D	5	73
20	7.5	55
16	13	50
12	23	42
10	33	34
8	46	26

Thread Sizes

Shell Size	Accessory Thread (6g 0.100R)	Mating Thread (0.1P-0.3L)	Jam Nut Thread (6g 0.100R)
9	M12 x 1.0	.6250	M17 x 1.0
11	M15 x 1.0	.7500	M20 x 1.0
13	M18 x 1.0	.8750	M25 x 1.0
15	M22 x 1.0	1.0000	M28 x 1.0
17	M25 x 1.0	1.1875	M32 x 1.0
19	M28 x 1.0	1.2500	M35 x 1.0
21	M31 x 1.0	1.3750	M38 x 1.0
23	M34 x 1.0	1.5000	M41 x 1.0
25	M37 x 1.0	1.6250	M44 x 1.0



DTS-B Bronze Connectors

38999 Series III-Style Connectors

Part Numbering

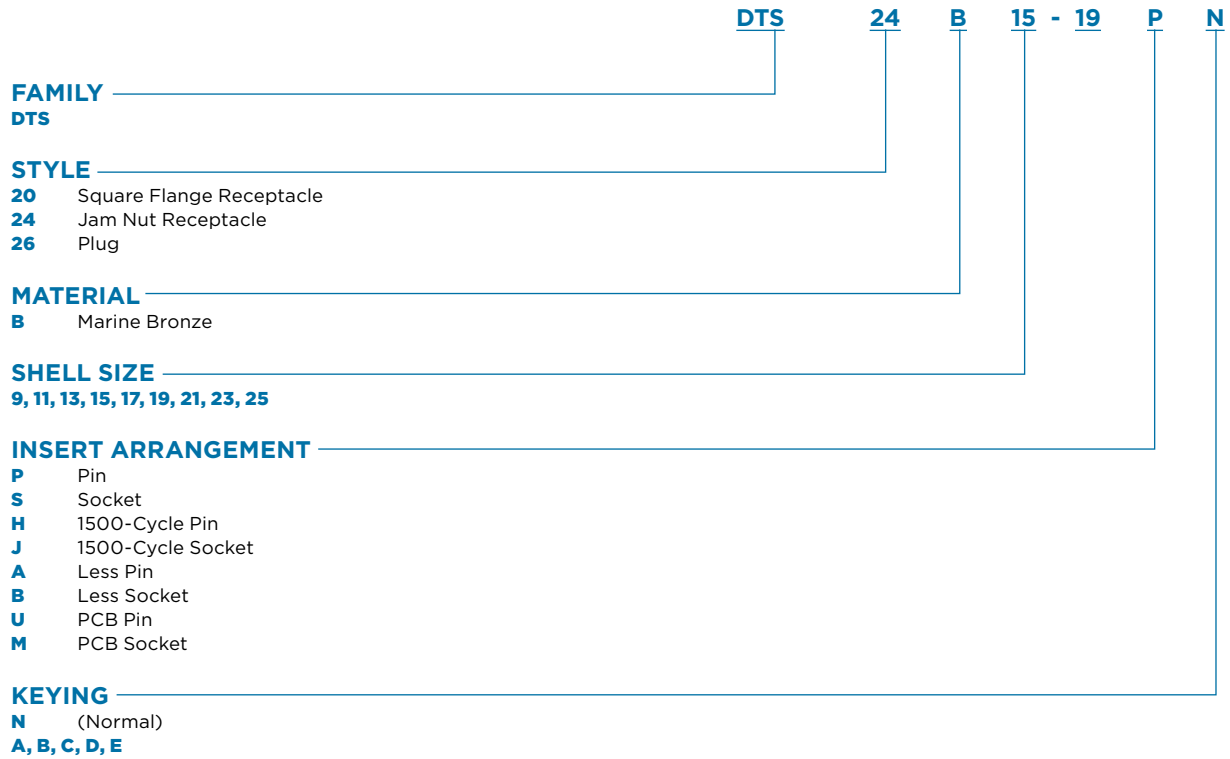



DTS-B Bronze Connectors

38999 Series III-Style Connectors

Square Flange Receptacle
Type 20

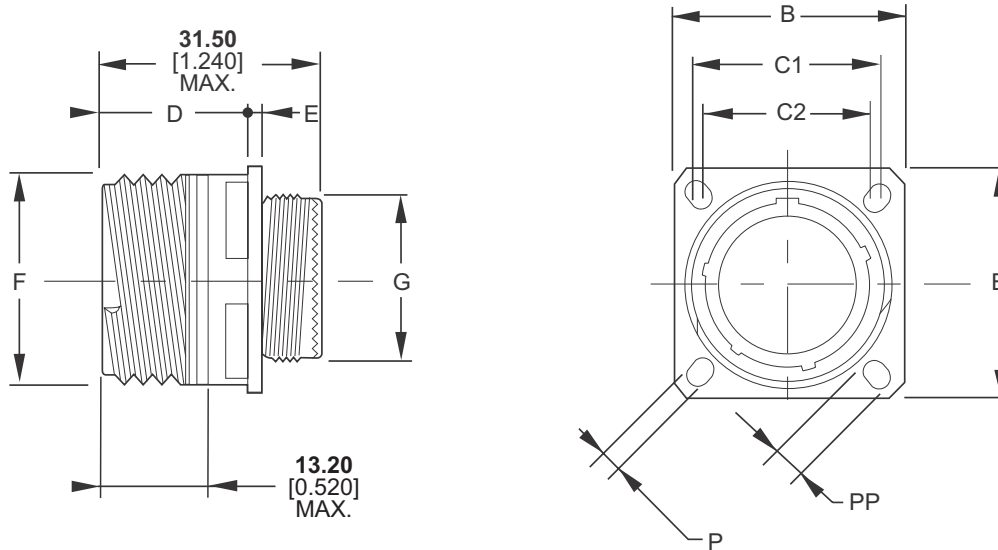

Shell Size	B ±0.3 (±0.012)	C1	C2	D Max.	E Max.	F ±0.1 (±0.004)	G ±0.1 (±0.004)	P ±0.2 (±0.008)	PP ±0.2 (±0.008)
09	23.80 0.937	18.26 0.719	15.09 0.594	20.90 0.823	2.50 0.098	15.75 0.620	11.90 0.469	3.25 0.128	5.49 0.216
11	26.20 1.031	20.62 0.812	18.26 0.719	20.90 0.823	2.50 0.098	18.90 0.744	14.90 0.587	3.25 0.128	4.93 0.194
13	28.60 1.126	23.01 0.906	20.62 0.812	20.90 0.823	2.50 0.098	22.10 0.870	17.90 0.705	3.25 0.128	4.93 0.194
15	31.00 1.220	24.61 0.969	23.01 0.906	20.90 0.823	2.50 0.098	25.25 0.994	21.90 0.862	3.25 0.128	4.93 0.194
17	33.30 1.311	26.97 1.062	24.61 0.969	20.90 0.823	2.50 0.098	29.95 1.179	24.90 0.980	3.25 0.128	4.93 0.194
19	36.50 1.437	29.36 1.156	26.97 1.062	20.90 0.823	2.50 0.098	31.55 1.242	27.90 1.098	3.25 0.128	4.93 0.194
21	39.70 1.563	31.75 1.250	29.36 1.156	20.10 0.791	3.20 0.126	34.70 1.366	30.90 1.217	3.25 0.128	4.93 0.194
23	42.90 1.689	34.93 1.375	31.75 1.250	20.10 0.791	3.20 0.126	37.90 1.492	33.90 1.335	3.91 0.154	6.15 0.242
25	46.00 1.811	38.10 1.500	34.93 1.375	20.10 0.791	3.20 0.126	41.10 1.618	36.90 1.453	3.91 0.154	6.15 0.242

Millimeters Inches



DTS-B Bronze Connectors

38999 Series III-Style Connectors

Jam Nut Receptacle
Type 24

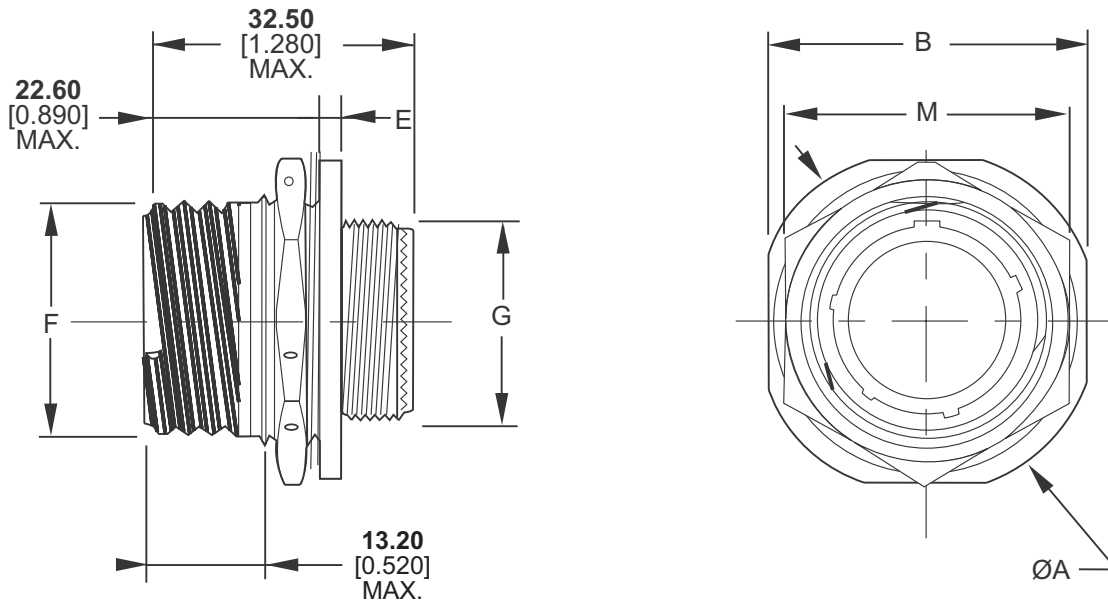

Shell Size	A ±0.3 (±0.012)	B ±0.4 (±0.016)	E +0.07/-0.1 (+0.028/-0.004)	F ±0.1 (±0.004)	G ±0.1 (±0.004)	M
09	30.20 1.189	27.00 1.063	2.20 0.087	15.75 0.620	11.90 0.469	21.82 0.859
11	34.90 1.374	31.80 1.252	2.20 0.087	18.90 0.744	14.90 0.587	24.99 0.984
13	38.10 1.500	34.90 1.374	2.20 0.087	22.10 0.870	17.90 0.705	29.77 1.172
15	41.30 1.626	38.10 1.500	2.20 0.087	25.25 0.994	21.90 0.862	32.91 1.296
17	44.50 1.752	41.30 1.626	2.20 0.087	29.95 1.179	24.90 0.980	36.12 1.422
19	49.20 1.937	46.00 1.811	3.00 0.118	31.55 1.242	27.90 1.098	39.25 1.545
21	52.40 2.063	49.20 1.937	3.00 0.118	34.70 1.366	30.90 1.217	42.47 1.672
23	55.60 2.189	52.40 2.063	3.00 0.118	37.90 1.492	33.90 1.335	45.61 1.796
25	58.70 2.311	55.20 2.173	3.00 0.118	41.10 1.618	36.90 1.453	49.25 1.939

Millimeters Inches



DTS-B Bronze Connectors

38999 Series III-Style Connectors

Plug
Type 26

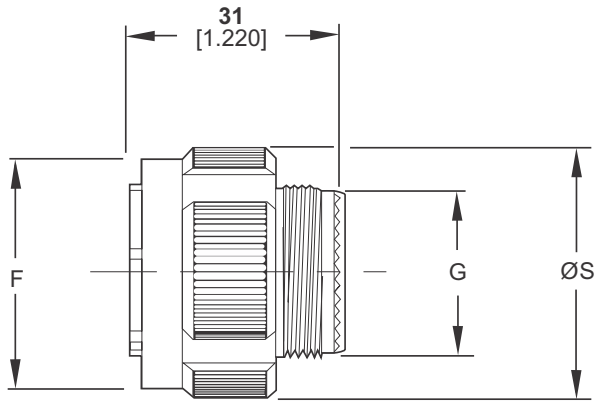

Shell Size	F Max.	G Max.	S Max.
09	18.40 0.724	11.90 0.469	21.80 0.858
11	21.10 0.831	14.90 0.587	25.00 0.984
13	25.40 1.000	17.90 0.705	29.40 1.157
15	28.70 1.130	21.90 0.862	32.50 1.280
17	32.20 1.268	24.90 0.980	35.70 1.406
19	34.90 1.374	27.90 1.098	38.50 1.516
21	38.10 1.500	30.90 1.217	41.70 1.642
23	41.10 1.618	33.90 1.335	44.90 1.768
25	44.30 1.744	36.90 1.453	48.00 1.890

Millimeters Inches



DTS-B Bronze Connectors

38999 Series III-Style Connectors

Panel Cutouts

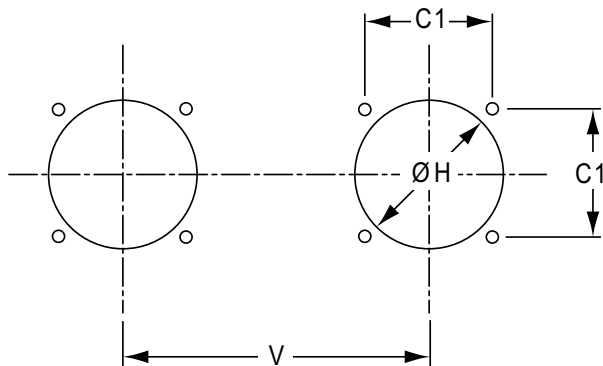

Square Flange Receptacle
(Type 20)

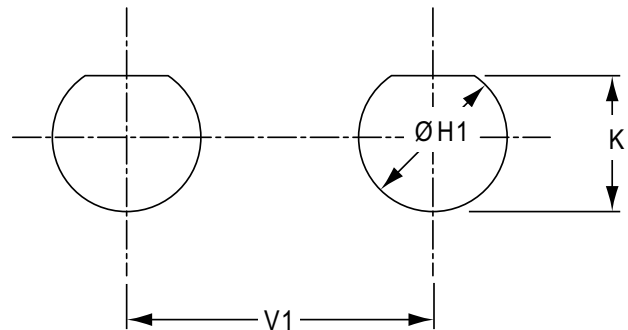

Jam Nut Receptacle
(Type 24)

Shell Size	C1	H Min.		H1 Max.	K Max.	V Min.	V1 Min.
		Front	Rear				
09	18.26 0.719	13.11 0.516	16.66 0.656	17.70 0.697	16.99 0.669	24.60 0.969	27.80 1.094
11	20.62 0.812	15.08 0.594	22.22 0.875	20.88 0.822	19.53 0.769	27.00 1.063	32.60 1.283
13	23.01 0.906	19.05 0.750	23.42 0.922	25.58 1.007	24.26 0.995	30.20 1.189	36.00 1.417
15	24.61 0.969	23.01 0.906	26.59 1.047	28.80 1.134	27.53 1.084	33.30 1.331	39.60 1.559
17	26.97 1.062	25.81 1.106	30.96 1.219	31.98 1.259	30.68 1.208	36.50 1.437	43.30 1.705
19	29.36 1.156	28.98 1.141	32.94 1.297	35.15 1.384	33.86 1.333	39.30 1.547	47.00 1.850
21	31.75 1.250	32.16 1.266	36.12 1.422	38.28 1.507	37.06 1.459	42.50 1.673	50.60 1.992
23	34.93 1.375	34.93 1.375	39.29 1.547	41.50 1.634	40.01 1.575	45.70 1.799	54.20 2.134
25	38.10 1.500	37.69 1.484	42.47 1.672	44.68 1.759	43.41 1.709	48.80 1.921	59.70 2.350

Millimeters Inches

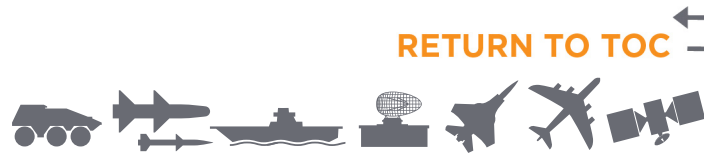

EASY TO USE

- Integrated backshell reduces assembly time
- Single or double knurled areas
- Terminate cable shield directly to the connector for optimal performance

HIGH-TEMPERATURE VERSIONS

- Class K stainless steel
- Temperatures to 200°C
- No costly and heavy backshell
- Connectors cable of receiving a shrink boot or cable overmold

SPACE AND WEIGHT SAVINGS

- Lower profile
- Lighter weight than assemblies with separate backshells

Series III Connectors with Integral Accessory



DEUTSCH DTS Connectors
DEUTSCH DTS Firewall Connectors

DEUTSCH connectors with integral accessory help provide space and weight savings over using a separate backshell. One or two knurled areas help support reliable shield termination with a band strap. The connectors also accept a heat-shrink boot or overmolding.

The connectors are available in aluminum with a variety of finishes or in stainless steel for Class K engine and firewall applications.



DTS Aluminum Connectors

Single Banding Sections

Part Numbering

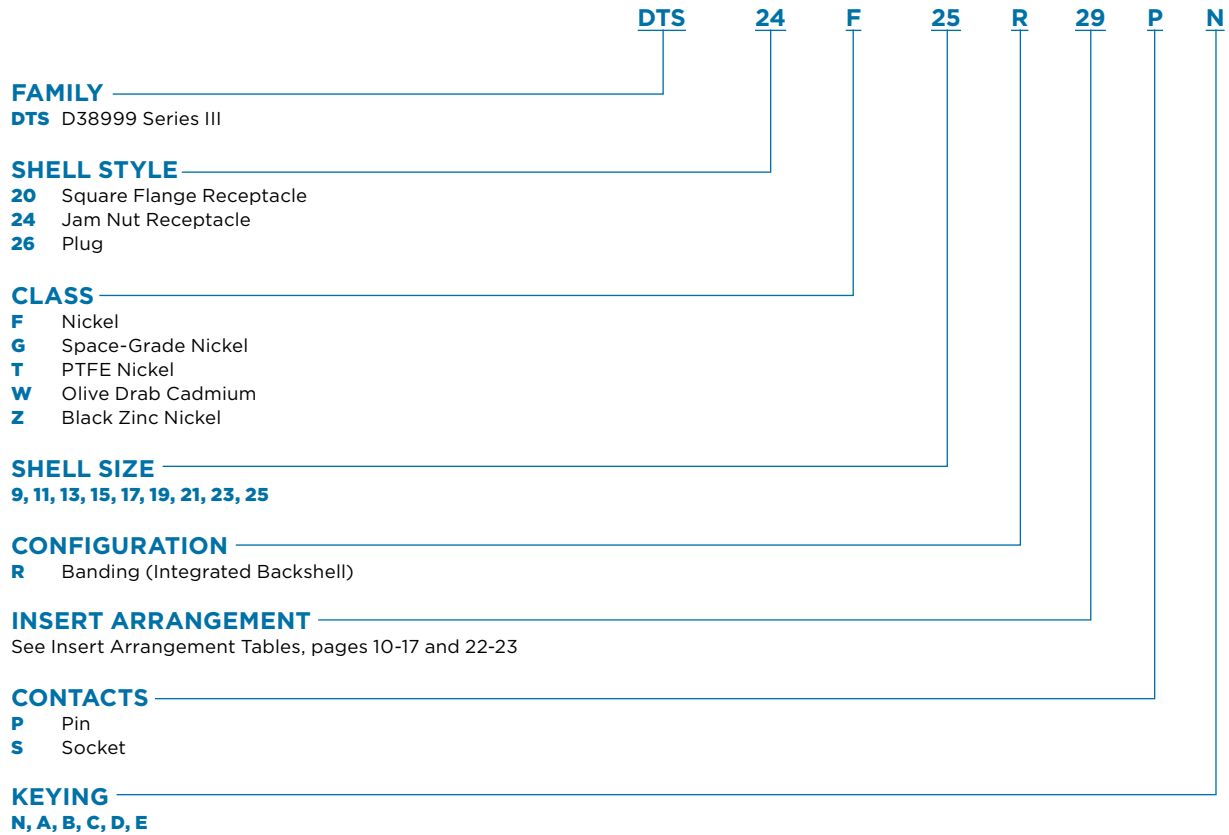

Note: If ordering less contacts, please add -6149 to the end of the part number



DTS Aluminum Connectors

Square Flange Receptacle

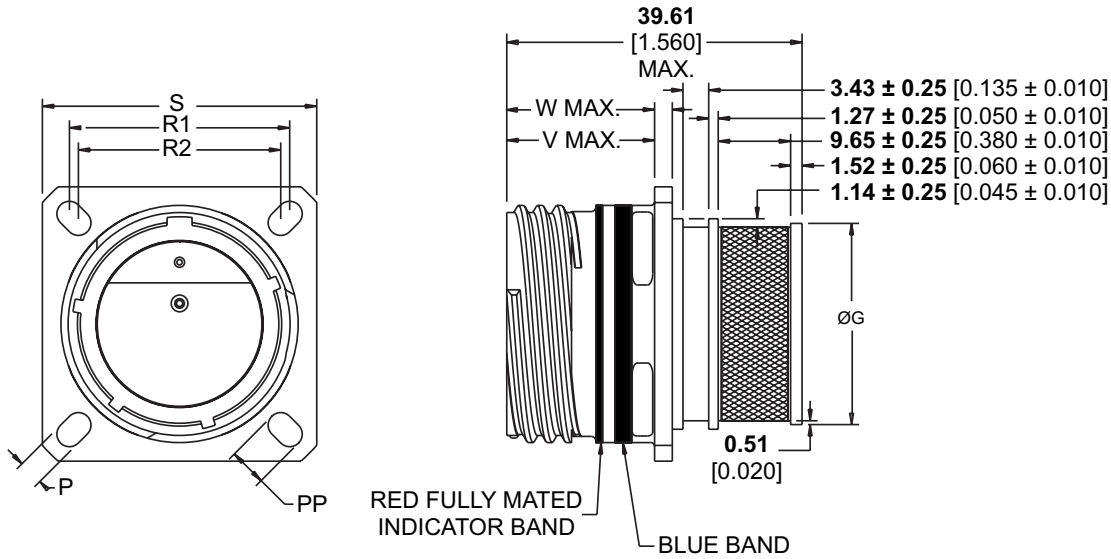

Shell Size	ØG±0.38 ±0.015	V	W	P	PP	R1	R2	S
09	11.43 0.450					18.26 0.719	15.09 0.594	23.80 0.937
11	14.63 0.576					20.62 0.812	18.26 0.719	26.19 1.031
13	17.53 0.690	20.88 0.822	2.49 0.098			23.01 0.906	20.62 0.812	28.60 1.126
15	20.83 0.820			3.25 0.128	4.93 0.194	24.61 0.969	23.01 0.906	30.99 1.220
17	23.83 0.938					26.97 1.062	24.61 0.969	33.30 1.311
19	26.82 1.056					29.36 1.156	26.97 1.062	36.50 1.437
21	29.82 1.174					31.75 1.250	29.36 1.156	39.70 1.563
23	32.82 1.292	20.09 0.791	3.20 0.126	3.91 0.154	6.15 0.242	34.93 1.375	31.75 1.250	42.90 1.689
25	35.81 1.410					38.10 1.500	34.93 1.375	46.00 1.811

Millimeters Inches



DTS Aluminum Connectors

Jam Nut Receptacle

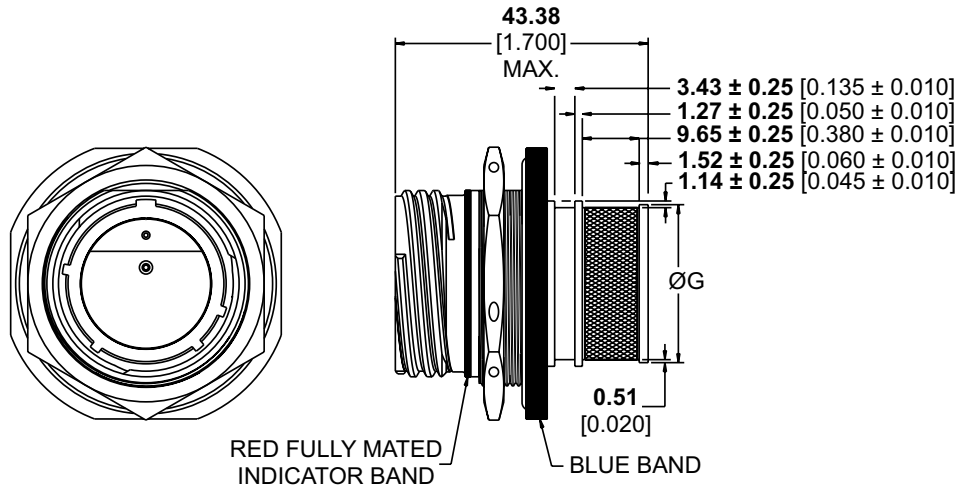

Shell Size	ØG ±0.38 ±0.015
09	11.43 0.450
11	14.63 0.576
13	17.53 0.690
15	20.83 0.820
17	23.83 0.938
19	26.82 1.056
21	29.82 1.174
23	32.82 1.292
25	35.81 1.410

Millimeters Inches



DTS Aluminum Connectors

Plug

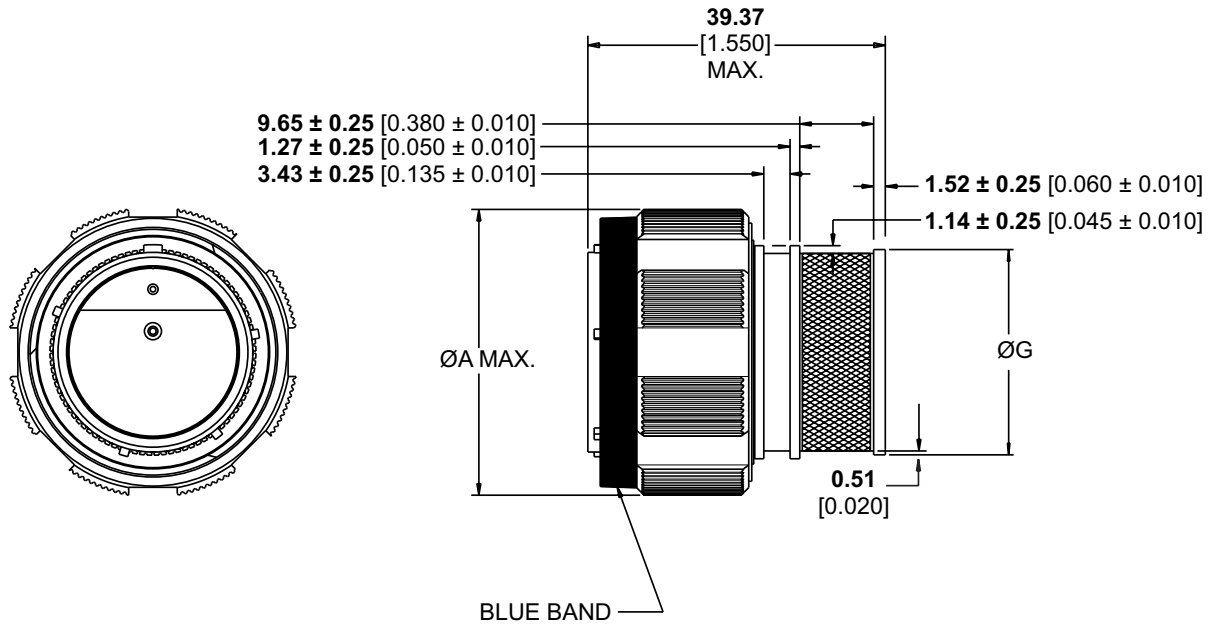

Shell Size	A	ØG ±0.38 ±0.015
09	21.79 0.858	11.43 0.450
11	24.99 0.984	14.63 0.576
13	29.39 1.157	17.53 0.690
15	32.49 1.279	20.83 0.820
17	35.69 1.405	23.83 0.938
19	38.48 1.515	26.82 1.056
21	41.68 1.641	29.82 1.174
23	44.91 1.768	32.82 1.292
25	47.98 1.889	35.81 1.410

Millimeters Inches



DTS-K Stainless Steel Firewall Connectors

Double Banding Sections

Part Numbers

xx = Insert Arrangement Code from dimensions table on next page

Polarization	Plug		Square Flange Receptacle		Jam Nut Receptacle	
	Pin Contact	Socket Contact	Pin Contact	Socket Contact	Pin Contact	Socket Contact
N	781-8037-xx	781-8057-xx	781-8060-xx	781-8070-xx	781-8043-xx	781-8049-xx
A	781-8131-xx	781-8141-xx	781-8061-xx	781-8071-xx	781-8044-xx	781-8050-xx
B	781-8132-xx	781-8142-xx	781-8062-xx	781-8072-xx	781-8045-xx	781-8051-xx
C	781-8133-xx	781-8143-xx	781-8063-xx	781-8073-xx	781-8046-xx	781-8052-xx
D	781-8134-xx	781-8144-xx	781-8064-xx	781-8074-xx	781-8047-xx	781-8053-xx
E	781-8135-xx	781-8145-xx	781-8065-xx	781-8075-xx	781-8048-xx	781-8054-xx

Square Flange Receptacle

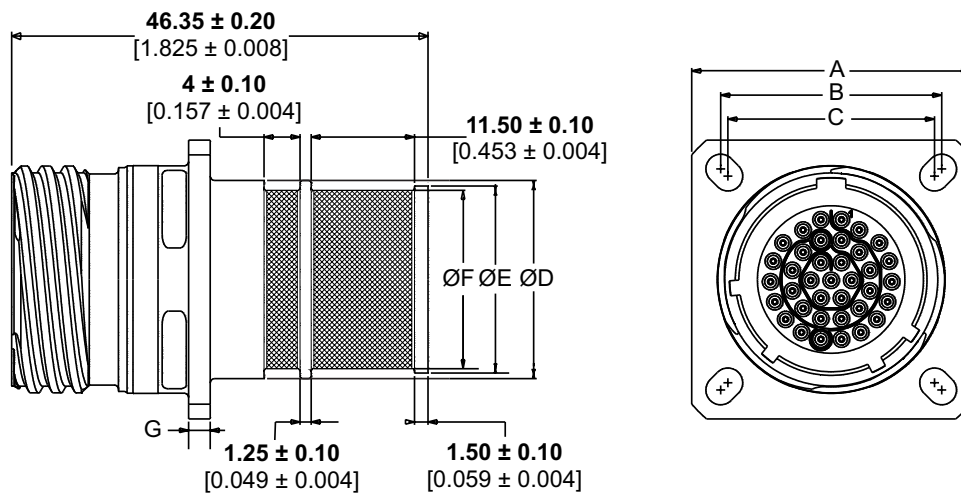



DTS-K Stainless Steel Firewall Connectors

Double Banding Sections

Insert Code	Size - Insert	A ± 0.3 ± 0.012	B ± 0.10 ± 0.005	C ± 0.10 ± 0.004	$\varnothing D \pm 0.12$ ± 0.005	$\varnothing E \pm 0.05$ ± 0.002	$\varnothing F \pm 0.05$ ± 0.002	G Max.
03	09-35	23.80	18.26	15.09	12.06	11.43	10.46	
05	09-98	0.937	0.719	0.594	0.475	0.450	0.412	
10	11-35							
11	11-98			18.26	15.06	14.63	13.67	
12	11-99	28.60	23.01					
14	13-08	1.126	0.906					
16	13-35			20.62	18.08	17.53	16.56	
17	13-98			0.812	0.712	0.690	0.652	
18	15-05							
20	15-18							2.50
21	15-19	31.00	24.61	23.01	22.07	20.83	19.86	0.098
22	15-35	1.220	0.969	0.906	0.869	0.820	0.782	
24	15-97							
25	17-06							
26	17-08	33.30	26.97	24.61	25.07	23.83	22.86	
27	17-26	1.311	1.062	0.969	0.987	0.938	0.900	
28	17-35							
31	19-11	36.50	29.36	26.97	28.07	26.83	25.86	
34	19-32	1.437	1.156	1.062	1.105	1.056	1.018	
46	21-39	39.70	31.75	29.36	31.06	29.82	28.91	
47	21-41	1.563	1.250	1.156	1.223	1.174	1.138	
55	23-53	42.90	34.93	31.75	34.06	32.82	31.85	3.20
61	25-04	1.689	1.375	1.250	1.341	1.292	1.254	0.126
65	25-35	46.00	38.10	34.93	37.06	35.81	34.85	
68	25-61	1.811	1.500	1.375	1.459	1.410	1.372	

Millimeters Inches



DTS-K Stainless Steel Firewall Connectors

Double Banding Sections

Plug

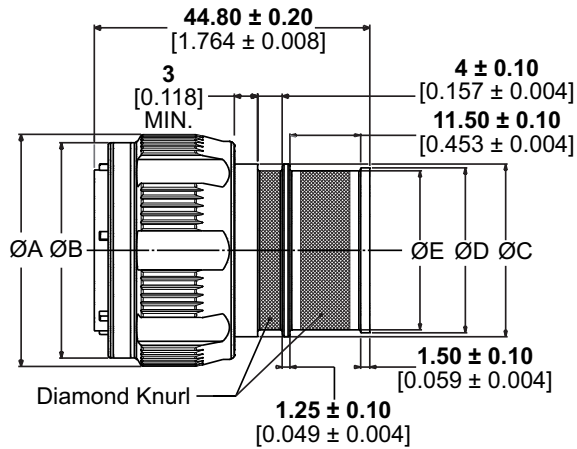

Insert Code	Size - Insert	ØA Max.	ØB Max.	ØC ±0.12 ±0.005	ØD ±0.05 ±0.002	ØE ±0.05 ±0.002
03	09-35	21.80	18.60	12.06	11.43	10.46
05	09-98	0.858	0.732	0.475	0.450	0.412
10	11-35	25.0	21.30	15.06	14.63	13.67
11	11-98	0.984	0.839	0.593	0.576	0.538
14	13-08					
16	13-35	29.40	25.60	18.08	17.53	16.56
17	13-98	1.157	1.008	0.712	0.690	0.652
18	15-05					
20	15-18					
21	15-19	32.50	28.90	22.07	20.83	19.86
22	15-35	1.280	1.138	0.869	0.820	0.782
24	15-97					
25	17-06					
26	17-08	35.70	32.40	25.07	23.83	22.86
27	17-26	1.406	1.276	0.987	0.938	0.900
28	17-35					
31	19-11					
34	19-32	38.50	35.10	28.07	26.83	25.86
35	19-35	1.516	1.382	1.105	1.056	1.018
45	21-35					
46	21-39	41.70	38.30	31.06	29.82	28.91
47	21-41	1.642	1.508	1.223	1.174	1.138
55	23-53	44.90	41.30	34.06	32.82	31.85
		1.768	1.626	1.341	1.292	1.254
61	25-04					
65	25-35	48.00	44.50	37.06	35.81	34.85
		1.890	1.752	1.459	1.410	1.372
68	25-61					

Millimeters Inches



DTS-K Stainless Steel Firewall Connectors

Single Banding Sections

Part Numbers

xx = Insert Arrangement Code from dimensions table on next page

Polarization	Plug		Square Flange Receptacle		Jam Nut Receptacle	
	Pin Contact	Socket Contact	Pin Contact	Socket Contact	Pin Contact	Socket Contact
N	781-8130-xx	781-8010-xx	781-8020-xx	781-8030-xx	781-8043-xx	781-8049-xx
A	781-8131-xx	781-8011-xx	781-8021-xx	781-8031-xx	781-8044-xx	781-8050-xx
B	781-8132-xx	781-8012-xx	781-8022-xx	781-8032-xx	781-8045-xx	781-8051-xx
C	781-8133-xx	781-8013-xx	781-8023-xx	781-8033-xx	781-8046-xx	781-8052-xx
D	781-8134-xx	781-8014-xx	781-8024-xx	781-8034-xx	781-8047-xx	781-8053-xx
E	781-8135-xx	781-8015-xx	781-8025-xx	781-8035-xx	781-8048-xx	781-8054-xx

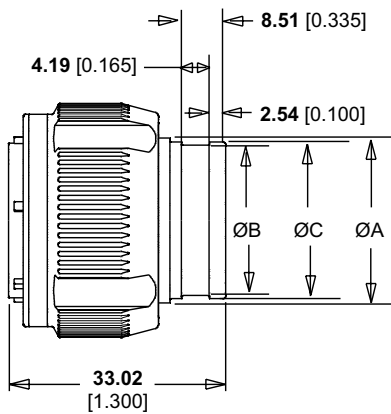

Plug

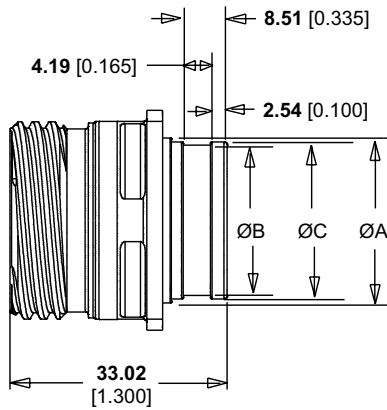

Square Flange Receptacle

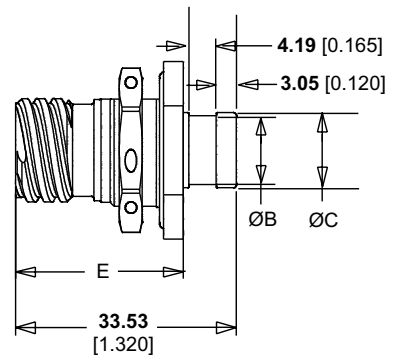

Jam Nut Receptacle



DTS-K Stainless Steel Firewall Connectors

Insert Code (xx)	Size - Insert	$\text{ØA} \pm 0.12$ ± 0.005	$\text{ØB} \pm 0.05$ ± 0.002	$\text{ØC} \pm 0.05$ ± 0.002	ØD Min.	E Max.			
03	9-35	12.06	10.46	11.43	13.46	25.60			
05	9-98	0.475	0.412	0.450	0.530	1.008			
11	11-98	15.06	13.67	14.63	TBD	TBD			
14	13-8	18.08	16.56	17.53					
17	13-98	0.712	0.652	0.690					
18	15-05	22.07	19.86	20.83	22.86	25.60			
20	15-18						0.869	0.782	0.820
21	15-19						0.869	0.782	0.820
25	17-6	25.07	22.86	23.83	25.86	1.008			
26	17-8						0.987	0.900	0.938
27	17-26						0.987	0.900	0.938
31	19-11	28.07	25.86	26.82	TBD	TBD			
34	19-32						1.105	1.018	1.056
46	21-39						1.223	1.138	1.174
47	21-41	31.06	28.91	29.82	TBD	TBD			
55	23-53						1.223	1.138	1.174
61	25-04						1.459	1.372	1.410
68	25-61	37.06	34.85	35.81					

Millimeters Inches

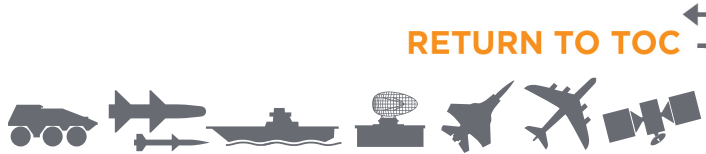
**ROBUST**

- Signal and power contacts in same housing
- Up to four 150 A or one 300 A high-current contacts
- Threaded coupling with self-locking mechanism for anti-vibration
- 100% scoop-proof design

RELIABLE

- Excellent contact retention under severe vibration
- Dedicated sealed backfitting and cable support grommet
- Interfacial sealing helps provide protection against aggressive fluid and dust ingress

EMI PROTECTION

- RFI/EMI shielding fingers at mating interface

EASY TO USE

- Rear removable crimp contacts
- Standard AS39029 Size 20 contacts for signals
- Space saving with integral power and signal wires

DTS-HC High-Current Connectors**38999 Series III-Style Connectors**

DEUTSCH DTS-HC high-current circular connectors provide power connections in the familiar 38999 form factor. They are optimized for use in harsh high-vibration environments where space is at a premium.

With integral power and signal wires in some configurations, the connectors also help save space and give you a variety of versatile contact termination options.

Rated to 175°C, DTS-HC connectors are the rugged choice for high-temperature applications. In addition, interfacial sealing helps provide protection from dust and aggressive fluids, while shielding fingers at the mating interface provide excellent EMI and RFI protection.



Specifications

MATERIALS

- **Shell/Coupling Ring:** High-strength aluminum alloy
- **Plating:** Nickel (standard), olive drab cadmium, or zinc cobalt
- **Insulators:** High-performance thermoplastic
- **Seals:** Fluorinated silicone
- **Contacts:** Gold-plated copper alloy

ENVIRONMENTAL/MECHANICAL

- **Temperature:** -65°C to +175°C
- **Vibration:** Random, 50-2000 Hz, 5 g²/Hz (per MIL-DTL-38999)
- **Dielectric Withstand Voltage:** 1500 VAC
- **Insulation Resistance:** 5000 MΩ min., 500 VDC,
- **Durability:** 500 mating cycles
- **Altitude:** 30,000 m (100,000 ft.) max.

CURRENT RATING, CONTINUOUS

- **Size 00 Contact:** 300 A
- **Size 4 Contact:** 150 A
- **Size 20 Contact:** 7.5 A

POWER CABLE CONDUCTOR TYPE

- **Size 4:** 4 AWG, 8 mm², 16 mm² and 25 mm² conductor
- **Size 00:** 70 mm²

CONFIGURATIONS

- **Size 21 Shell:** 2 Size 4 power contacts
- **Size 23 Shell:** 1 Size 00 power contact
- **Size 23 Shell:** 2 Size 4 power contacts and 3 Size 20 contacts
- **Size 25 Shell:** 4 Size 4 power contacts and 4 Size 20 contacts

DTS-HC High-Current Connectors

38999 Series III-Style Connectors

Insert Arrangements

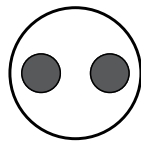

21-240
2 Size 4 Contacts

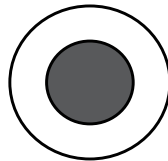

23-100
One Size 00 Contact

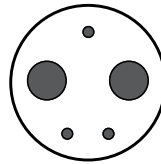

23-24320
2 Size 4 Contacts
3 Size 20 Contacts

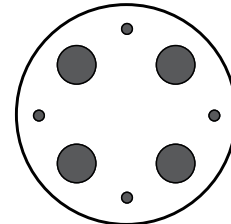

25-44420
4 Size 4 Contacts
4 Size 20 Contacts

Part Numbering

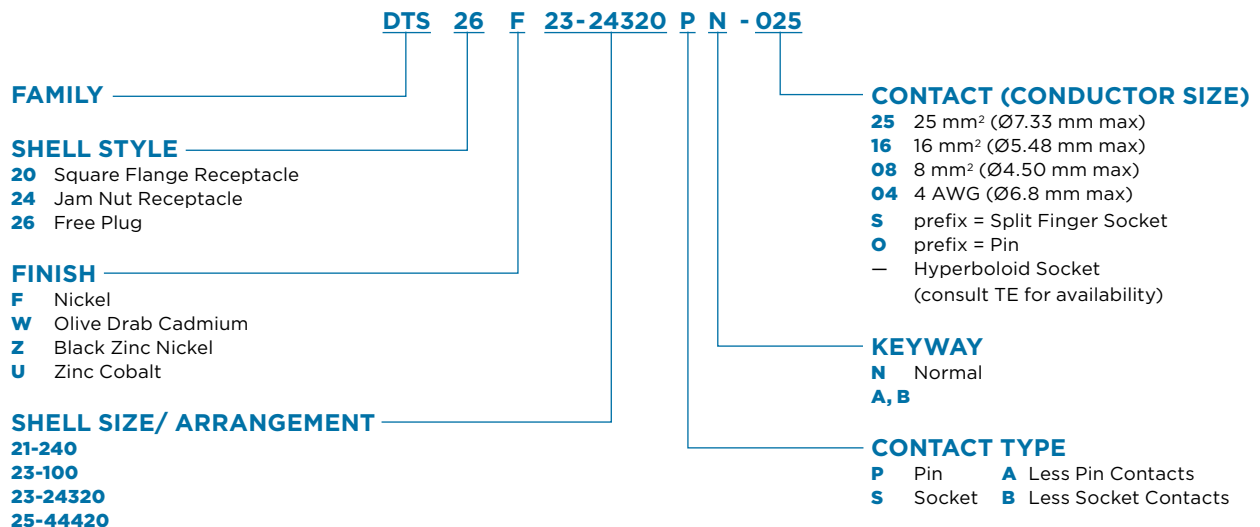



DTS-HC High-Current Connectors

38999 Series III-Style Connectors

Square Flange Receptacle Type 20

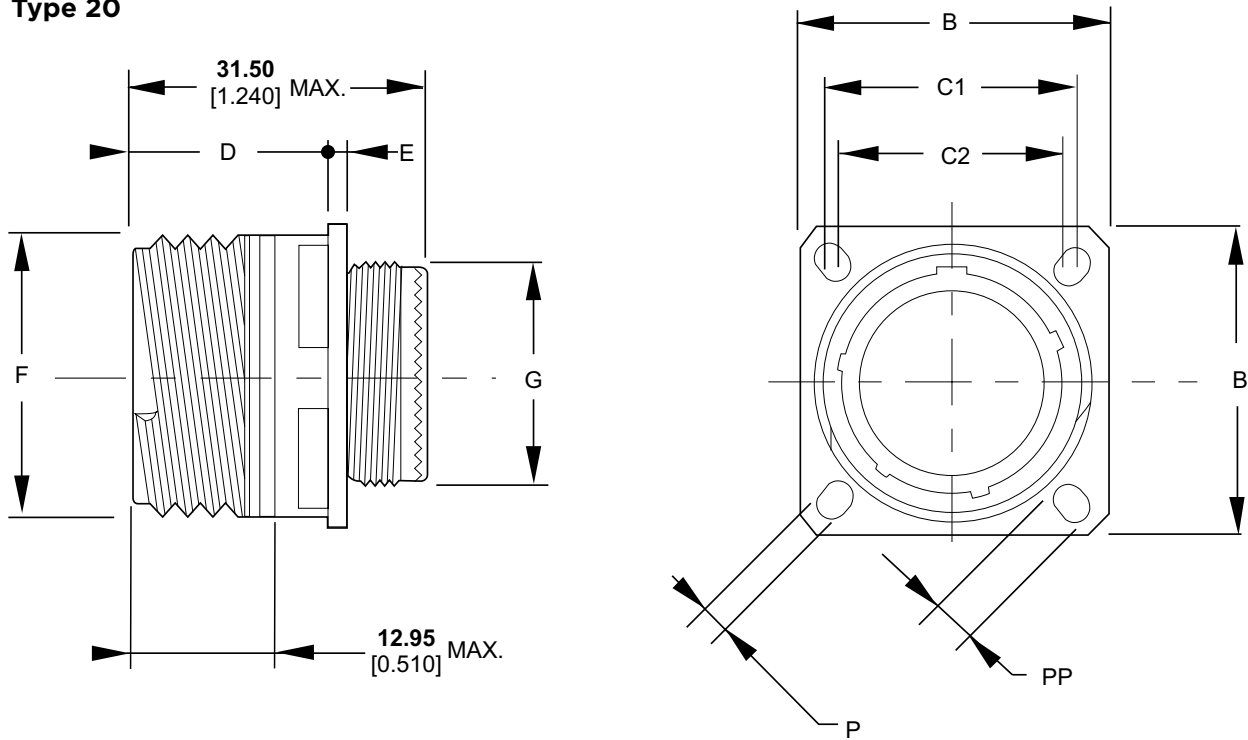

Shell Size	B	C1	C2	D Max.	E Max.	F	G	P	PP
21	39.70 1.563	31.75 1.250	29.36 1.156	20.10 0.791	3.20 0.126	34.70 1.366	30.90 1.217	3.25 0.128	4.93 0.194
23	42.90 1.689	34.93 1.375	31.75 1.250	20.10 0.791	3.20 0.126	37.90 1.492	33.90 1.335	3.91 0.154	6.15 0.242
25	46.00 1.811	38.10 1.500	34.93 1.375	20.10 0.791	3.20 0.126	41.10 1.618	36.90 1.453	3.91 0.154	6.15 0.242

Millimeters Inches



DTS-HC High-Current Connectors

38999 Series III-Style Connectors

Jam Nut Receptacle Type 24

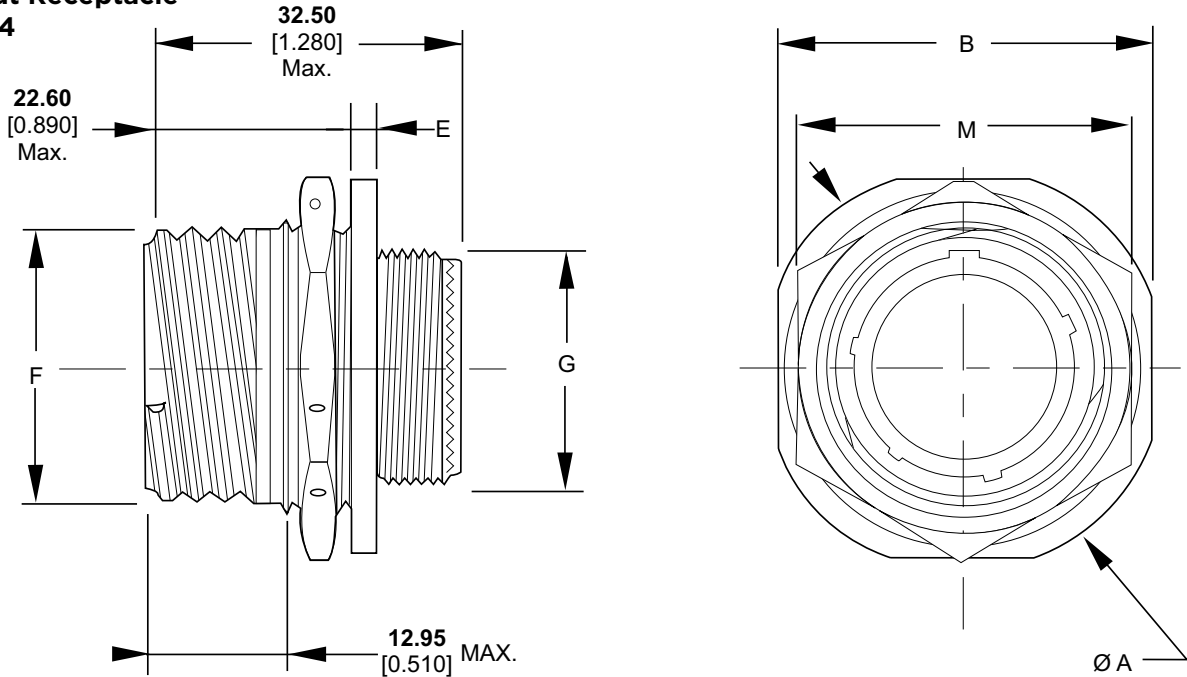

Shell Size	A	B	E Max.	F	G	M Max.
21	52.40 2.063	49.20 1.937	3.99 0.157	34.70 1.366	30.90 1.217	46.00 1.811
23	55.60 2.189	52.40 2.063	3.00 0.118	37.90 1.492	33.90 1.335	50.00 1.969
25	58.70 2.311	55.60 2.189	3.00 0.118	41.10 1.618	36.90 1.453	51.23 2.017

Millimeters Inches

Plug Type 26

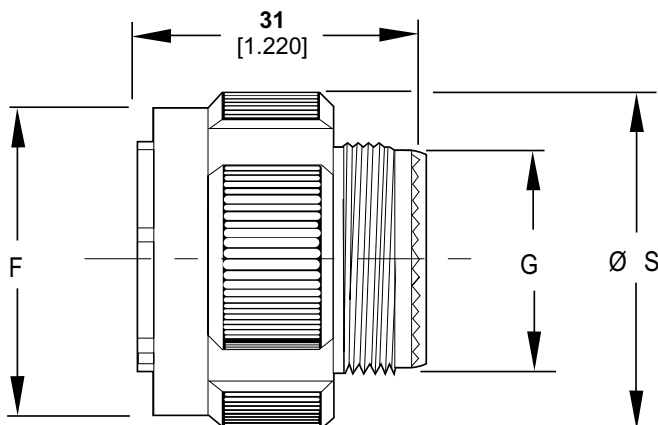

Shell Size	F Max.	G	S Max.	Mass (g)
21	38.10 1.500	30.90 1.217	41.70 1.642	55
23	41.10 1.618	33.90 1.335	44.90 1.768	67
25	44.30 1.744	36.90 1.453	48.00 1.890	71

Millimeters Inches



DTS-HC High-Current Connectors

38999 Series III-Style Connectors

Contacts

Contact Size	Conductor	Pin	Socket	Crimp Tool	Dieset or Positioner	Contact Removal Tool
20	24 - 20	38941-20	38943-20	M22520/2-01	M22520/2-10	M81969/14-10
8	6 mm ²	611091	611089	M22520/23-01	M22520/23-09	611218
	14 mm ²	605345-01-31	605344	Consult TE for Tooling		
4	4 AWG	611102	611103	D51	31040	610136-TOOL
	25 mm ²	605660	611103-025			
	16 mm ²	605734	611103-016			
	8 mm ²	611102	611103	M22520/23-01 or D51	M22520/23-11	610136-TOOL
00	70 mm ²	610304	601365	Consult TE for Tooling		
00 Bus Bar	**	610364	610299	—	—	—

** Consult TE



HIGH PERFORMANCE

- Up to 1000 A capability
- Rugged 38999-style connector and shell systems
- Rated -65°C to +175°C

CONVENIENT

- Variety of shell sizes
- Choose from straight or 90° configurations
- Threaded coupling and screened crimp termination options

EASY ASSEMBLY

- Simple adjustment of angled backshells (no special tooling)
- Low mating force
- Conductive jam nut O-ring option available

POLAMCO High-Power Connectors



38999-Style Connectors for Harsh Military Environments

The POLAMCO high-power connector family provides a simple and effective way of terminating power cables in a harsh environment military connector system.

POLAMCO high-power connectors are optimized for cable sizes ranging from 50 mm² up to 240 mm², and are available in shell sizes 19 through 25, depending on the cable being terminated.

Rated to 175°C, these high-power MIL-DTL-38999 Series I and III-style connector systems give you a variety of versatile options including threaded termination or a screened crimp, with straight or 90° orientation.



Specifications

MATERIALS

- **Shell:** High-strength aluminum alloy, nickel aluminum bronze, or stainless steel
- **Contact Body:** Silver-plated copper alloy

- **Seals:** Silicone elastomer
- **Insulators:** Thermoplastic: PPS-GL40, UL94V-0
- **Plating Finishes:**
 - Olive drab cadmium
 - Black zinc nickel
 - Electroless nickel
 - Zinc cobalt
 - (Contact TE for additional finishes)

Plating Code	Plating Description	RoHS Compliant	Environmental Protection Conductivity
B	Olive drab cadmium (5-10 μm) QQ-P-416, Type II, Class 3 over electroless nickel	No	500 hours salt spray
C	Electroless nickel, AMS-C-26047, Class 4, Grade B	Yes	48 hours salt spray
ZB	Zinc cobalt (5-10 μm) over electroless nickel (2.5-7.5 μm) with an olive drab chromate conversion	Yes	350 hours salt spray
ZN	Passivated black zinc nickel (5-12 μm) over electroless nickel (8-12 μm), ASTM B 841 Class 1	Yes	500 hours salt spray
ZK	Zinc cobalt (5-10 μm) over electroless nickel (2.5-7.5 μm) with a black chromate conversion	Yes	500 hours salt spray

ELECTRICAL

- **Voltage:** 1800 VAC / 60 Hz (service rating 1)
- **Shell Continuity:** <5 mΩ
- **Current Rating (Approx. @ 40°C ambient):**
 - Shell Size 25:** 1000 A, <22 μΩ
 - Shell Size 23:** 800 A, <25 μΩ
 - Shell Size 21:** 600 A, <30 μΩ
 - Shell Size 19:** 400 A, <38 μΩ
- **Contact Resistance (Approx. @ 40°C ambient):**
 - Shell Size 25:** <22 μΩ
 - Shell Size 23:** <25 μΩ
 - Shell Size 21:** <30 μΩ
 - Shell Size 19:** <38 μΩ

ENVIRONMENTAL/MECHANICAL

- **Durability:** 500 mating cycles
- **Vibration:** 6 hours in 3 axis, full current load (Def-Stan 0035)
- **Shock:** 500 m/s², 11 ms half sine
- **Temperature:** -65°C to +175°C
- **Sealing:** IP68 (2 m for 0.5 hour)
- **Salt Spray:** Up to 500 hours (depending on material/finish)

CRIMP CONTACT CURRENT DE-RATING

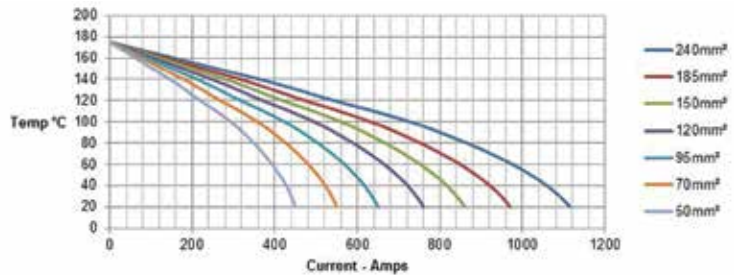



POLAMCO High-Power Connectors

Part Numbering

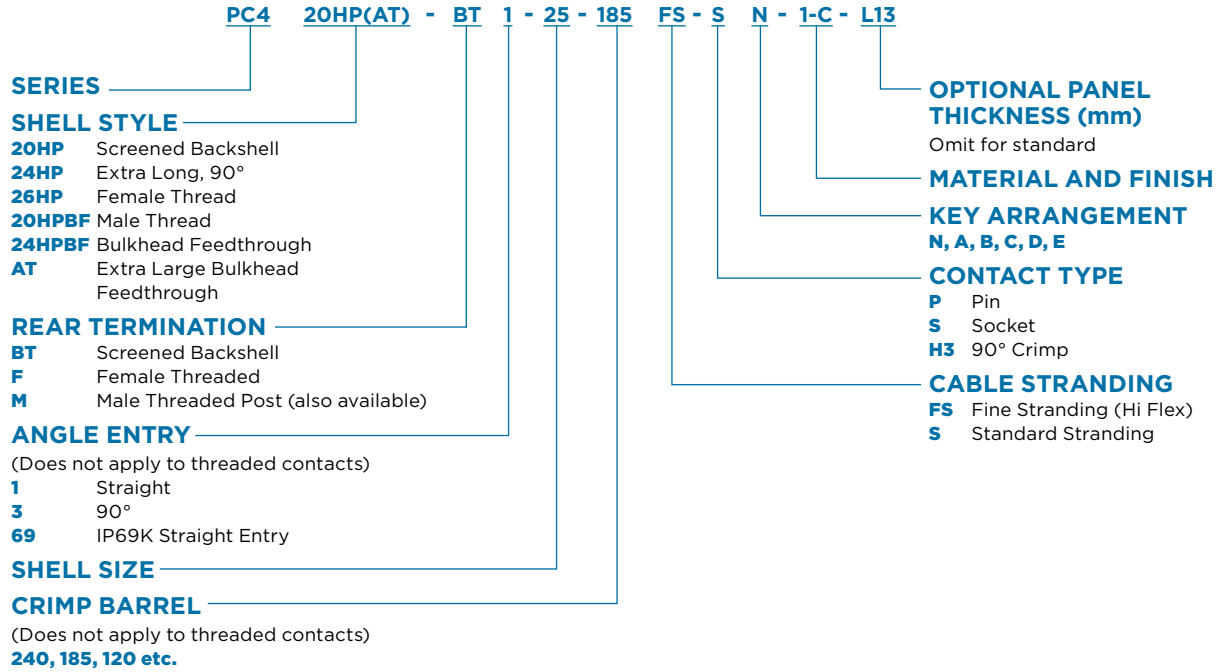

Material Description Codes

Material Code	Material Description
1	Aluminum Alloy 6262 / 6082
2	Nickel Aluminum Bronze DGS 1043 / NES 833 (Marine Applications)
4	Stainless Steel 303 S31 / 304
46	Stainless Steel 316



POLAMCO High-Power Connectors

Shielded Straight Plugs

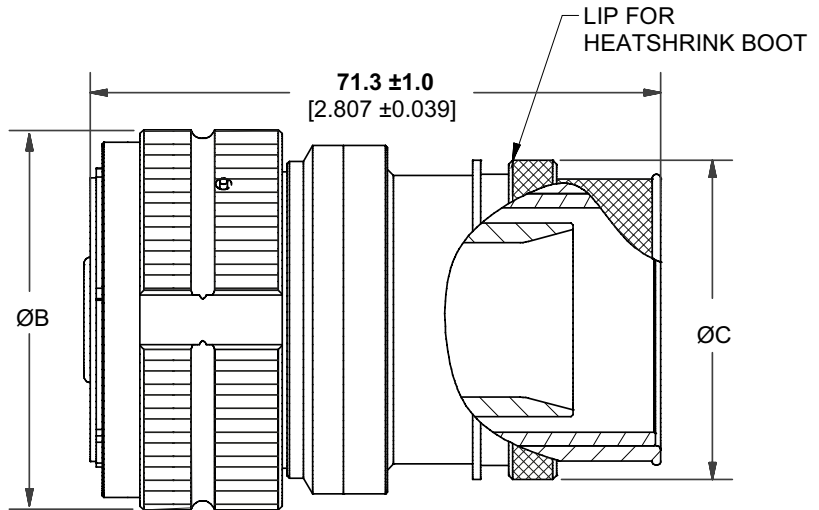
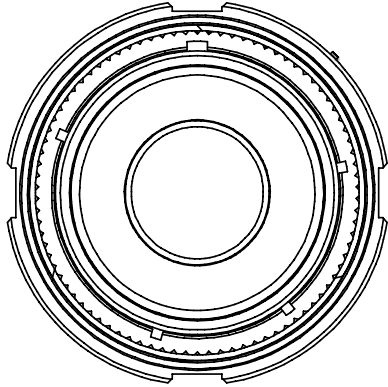

Shell Size	ØB Max.	ØC Max.
19	38.50 1.516	27.60 1.087
21	41.70 1.642	31.10 1.224
23	44.90 1.768	36.00 1.417
25	48.00 1.890	39.84 1.569

Millimeters Inches



POLAMCO High-Power Connectors

Shielded Right-Angle Plugs

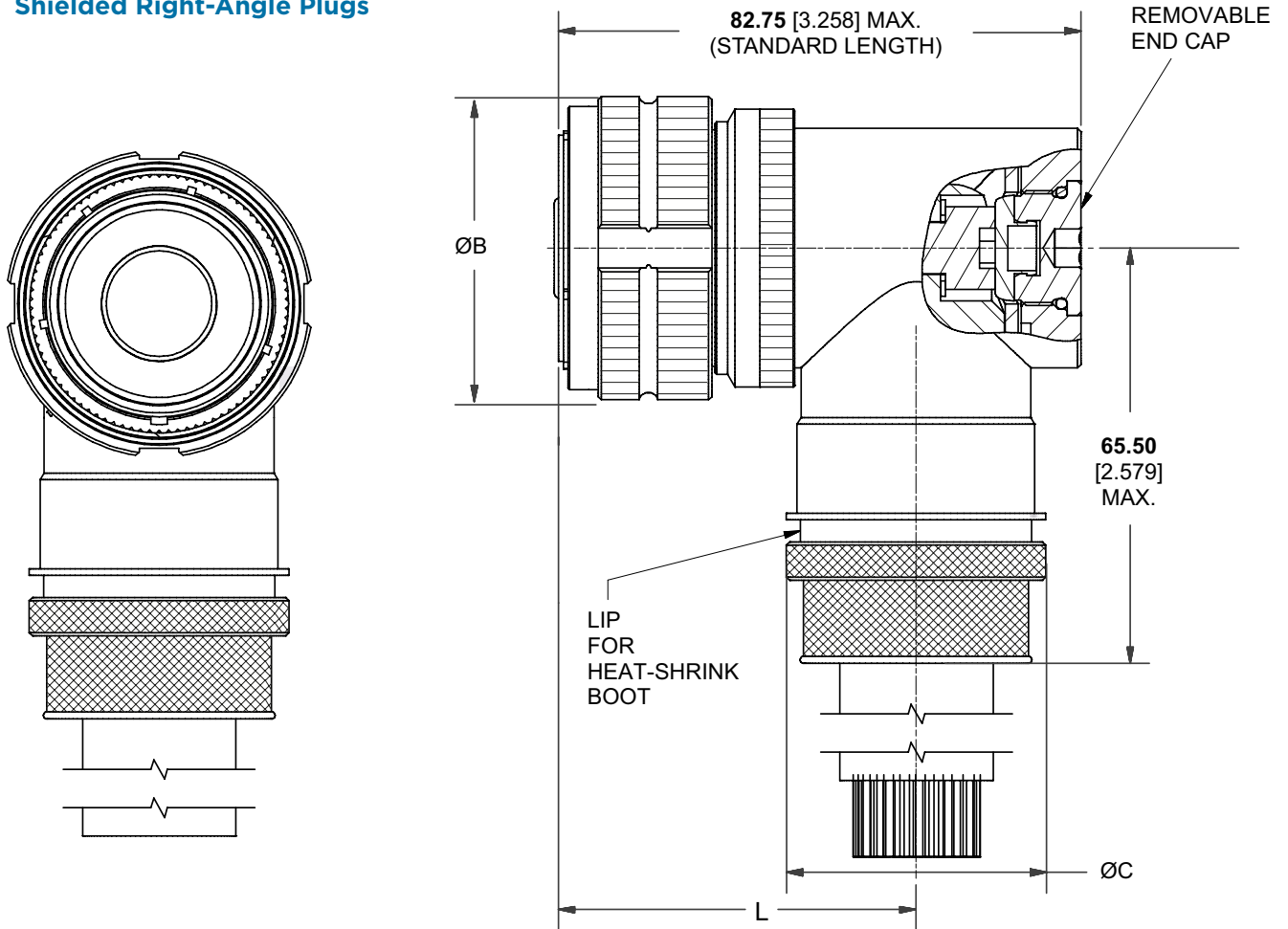

Shell Size	ØB Max.	ØC Max.	L	
			Standard	Extended
19	38.50 1.516	31.60 1.244	52.00 2.047	98.0 3.858
21	41.70 1.642	34.50 1.358	54.00 2.126	103.0 4.055
23	44.90 1.768	38.50 1.516	56.00 2.205	108.0 4.252
25	48.00 1.890	40.64 1.600	56.00 2.205	112.0 4.409

Millimeters Inches



POLAMCO High-Power Connectors

Shielded Jam Nut Receptacle

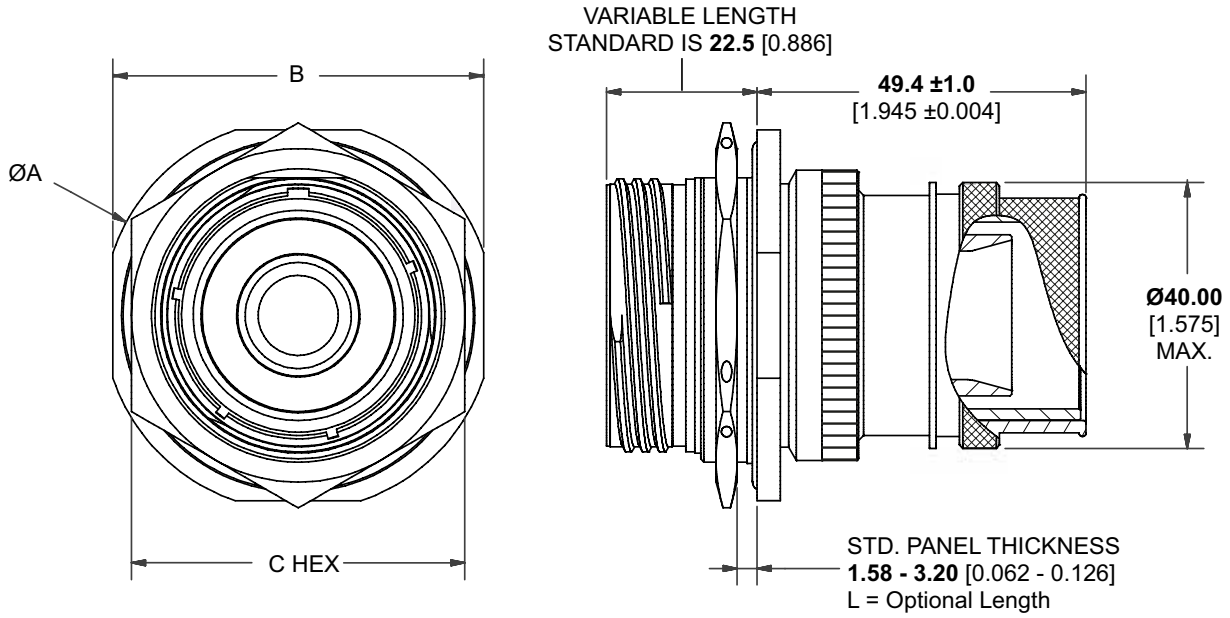

Shell Size	A	B	C	E	F	G
19	49.20 1.937	46.00 1.811	40.00 1.575	35.18 1.385	33.91 1.335	27.60 1.087
21	52.40 2.063	49.20 1.937	43.00 1.693	38.35 1.510	37.08 1.460	31.10 1.224
23	55.60 2.189	52.40 2.063	46.00 1.811	41.53 1.635	40.26 1.585	36.00 1.417
25	58.70 2.311	55.60 2.189	50.00 1.969	44.70 1.760	43.43 1.710	39.84 1.569

Millimeters Inches

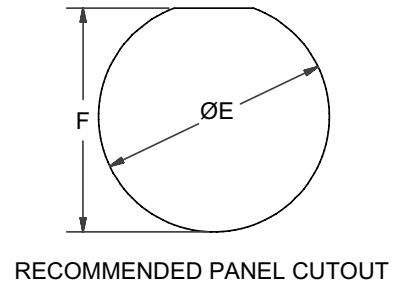

RECOMMENDED PANEL CUTOUT



POLAMCO High-Power Connectors

Shielded Square Flange Receptacle

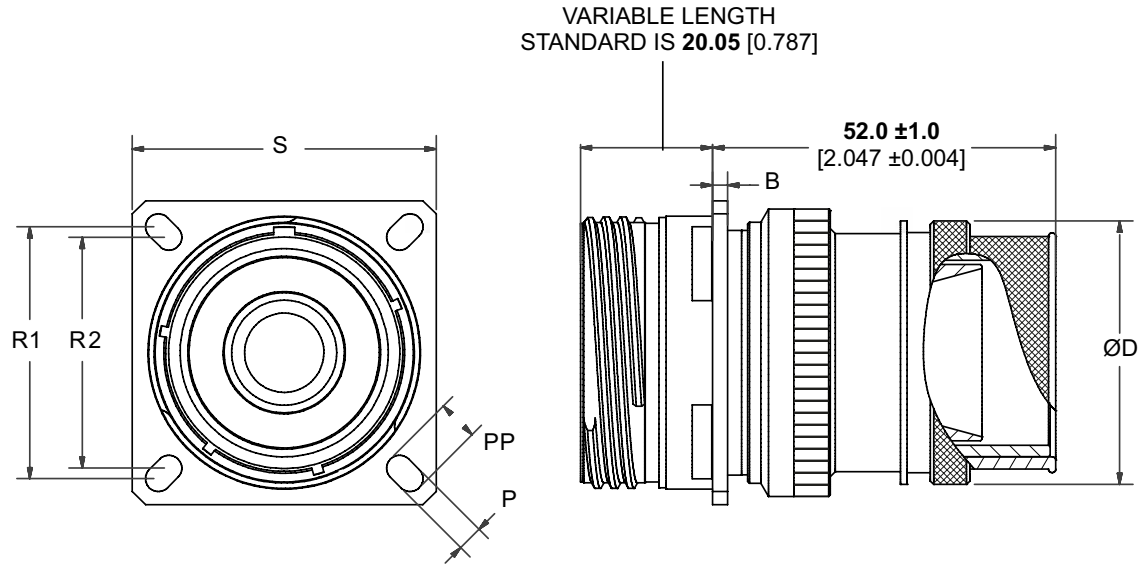

Shell Size	B	D	P	PP	R1	R2	S
19	2.30 0.091	27.60 1.087	3.25 0.128	4.93 0.194	29.36 1.156	26.97 1.062	36.50 1.437
21	3.00 0.118	31.10 1.224	3.25 0.128	4.93 0.194	31.75 1.250	29.36 1.156	39.70 1.563
23	3.00 0.118	36.00 1.417	3.91 0.154	6.15 0.242	34.93 1.375	31.75 1.250	42.90 1.689
25	3.00 0.118	39.84 1.569	3.91 0.154	6.15 0.242	38.10 1.500	34.93 1.375	46.00 1.811

Millimeters Inches



POLAMCO High-Power Connectors

Unshielded Jam Nut Receptacle

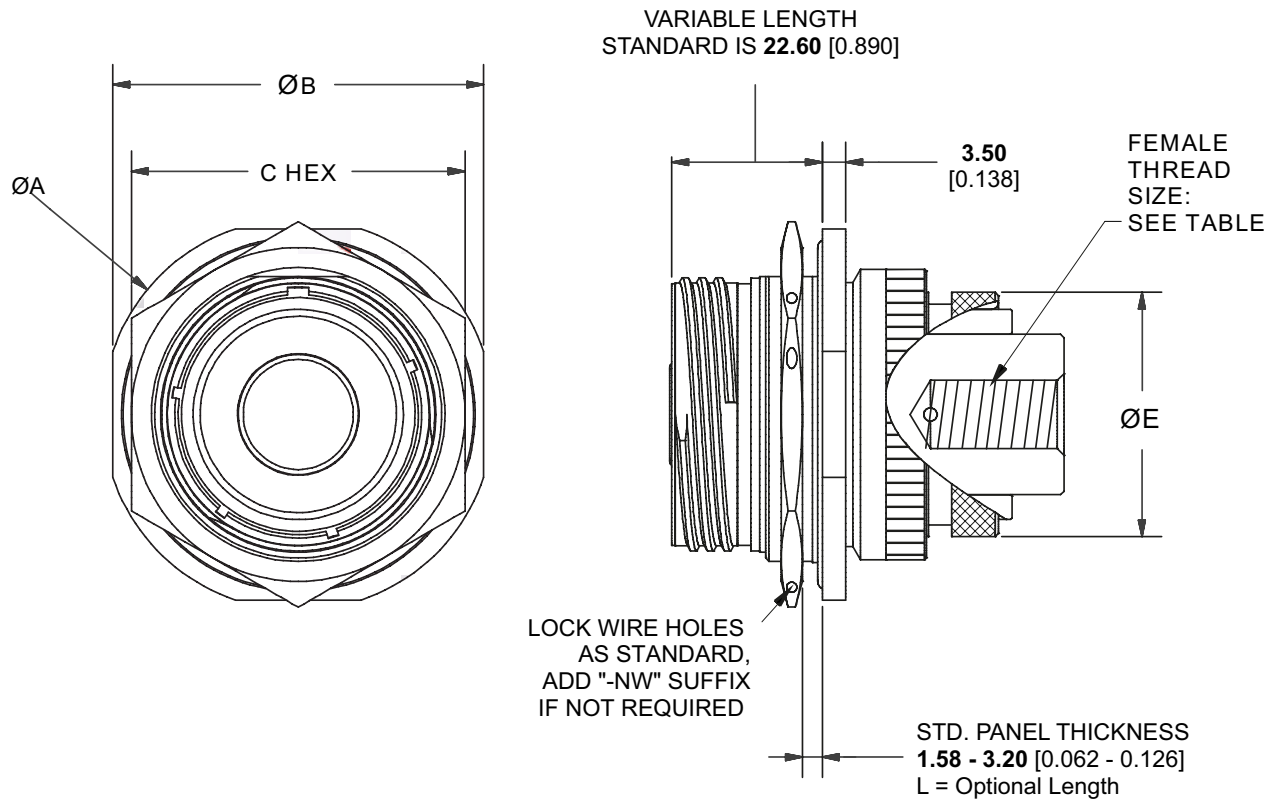

Shell Size	A	B	C	E	F	G	Female Thread Size
19	49.20 1.937	46.00 1.811	40.00 1.575	35.18 1.385	26.50 1.043	33.91 1.335	M8
21	52.40 2.063	49.20 1.937	43.00 1.693	38.35 1.510	31.00 1.220	37.08 1.460	M10
23	55.60 2.189	52.40 2.063	46.00 1.811	41.53 1.635	34.40 1.354	40.26 1.585	M10
25	58.70 2.311	55.60 2.189	50.00 1.969	44.70 1.760	36.60 1.441	43.43 1.710	M12

Millimeters Inches

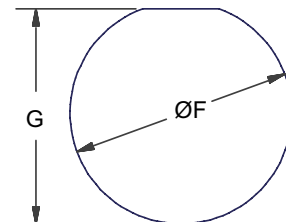

RECOMMENDED
PANEL CUTOUT



POLAMCO High-Power Connectors

Unshielded Square Flange Receptacle

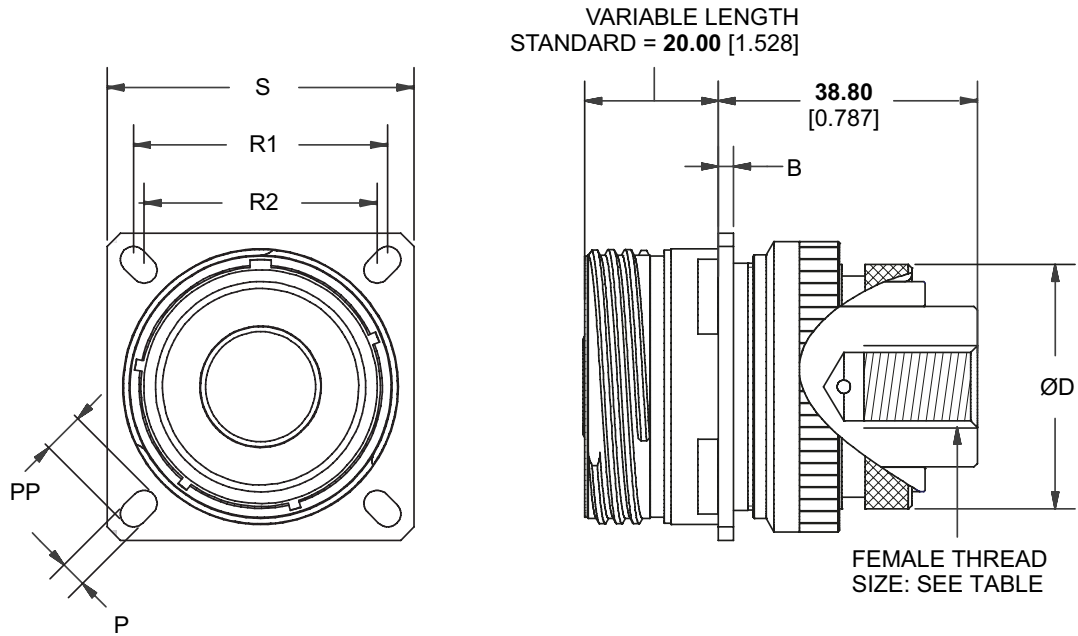

Shell Size	B	D	P	PP	R1	R2	S	Female Thread Size
19	2.30 0.091	27.50 1.043	3.25 0.128	4.93 0.194	29.36 1.156	26.97 1.062	36.50 1.437	M8
21	3.00 0.118	31.10 1.224	3.25 0.128	4.93 0.194	31.75 1.250	29.36 1.156	39.70 1.563	M10
23	3.00 0.118	34.40 1.354	3.91 0.154	6.15 0.242	34.93 1.375	31.75 1.250	42.90 1.689	M10
25	3.00 0.118	36.60 1.441	3.01 0.119	6.15 0.242	38.10 1.500	34.93 1.375	46.00 1.811	M12

Millimeters Inches



POLAMCO High-Power Connectors
Bulkhead Feedthrough Jam Nut Receptacle

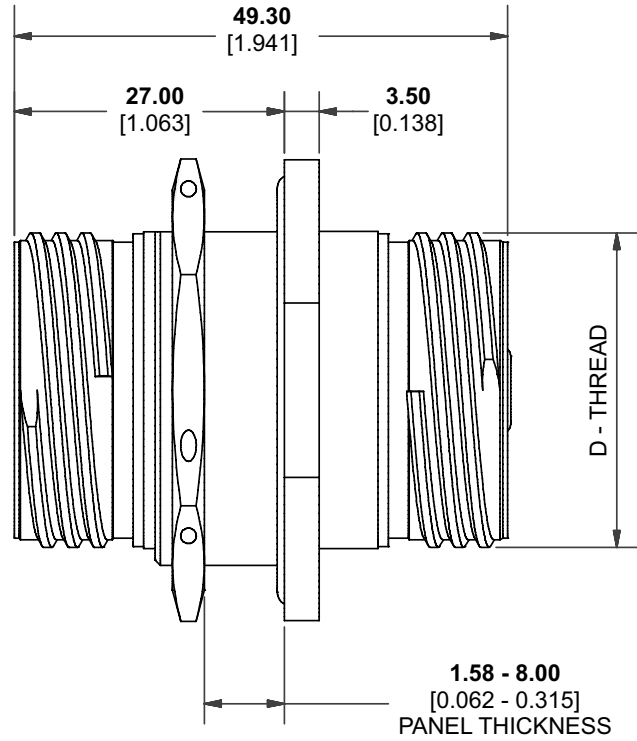
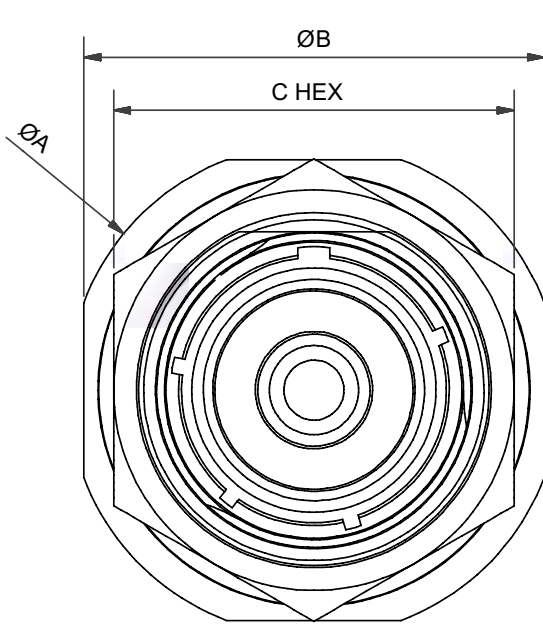

Shell Size	A	B	C	E	F
19	49.20 1.937	46.00 1.811	40.00 1.575	35.18 1.385	33.91 1.335
21	52.40 2.063	49.20 1.937	43.00 1.693	38.35 1.510	37.08 1.460
23	55.60 2.189	52.40 2.063	46.00 1.811	41.53 1.635	40.26 1.585
25	58.70 2.311	55.60 2.189	50.00 1.969	44.70 1.760	43.43 1.710

Millimeters Inches



POLAMCO High-Power Connectors

Bulkhead Feedthrough Square Flange Receptacle

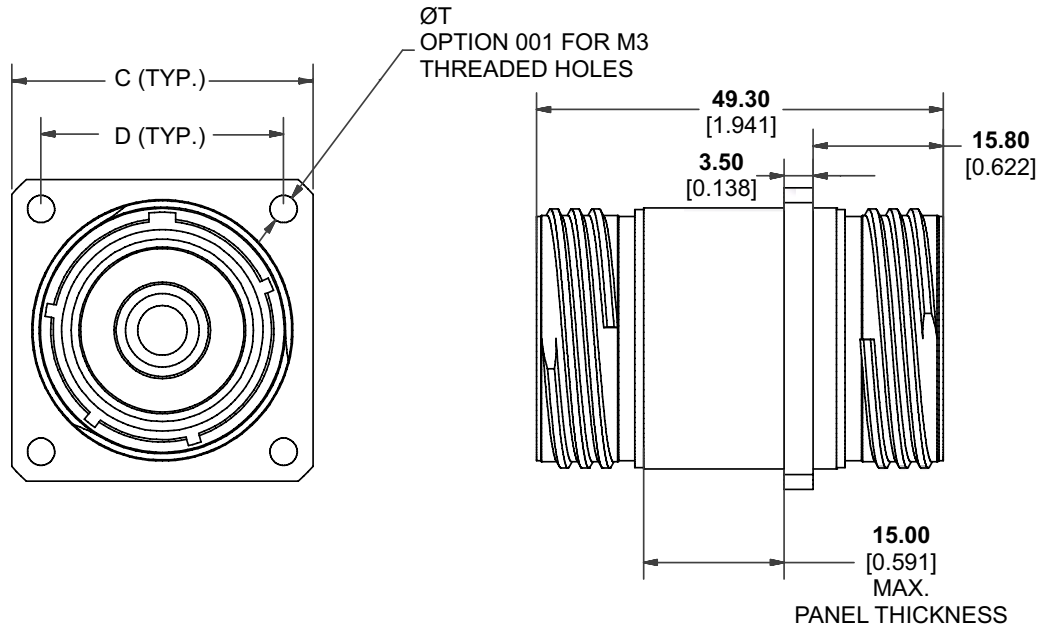

Shell Size	C	D	H	T
19	36.50 1.437	29.40 1.157	32.94 1.297	3.30 0.130
21	39.70 1.563	31.80 1.252	36.29 1.429	
23	42.90 1.689	34.90 1.374	39.29 1.547	
25	46.00 1.811	38.10 1.500	42.47 1.672	

Millimeters Inches



POLAMCO High-Power Connectors

Power Crimp Contacts

Dimensions

Crimp Size (CSA, mm ²)	øA Max.	
	Standard Cable	Fine Stranded Cable
50	10.00 0.394	10.30 0.406
70	11.30 0.445	12.10 0.476
95	13.50 0.531	14.20 0.559
120	15.20 0.598	16.50 0.650
150	16.70 0.657	17.60 0.693
185	19.20 0.756	19.20 0.756
240	21.10 0.831	N/A

Millimeters Inches

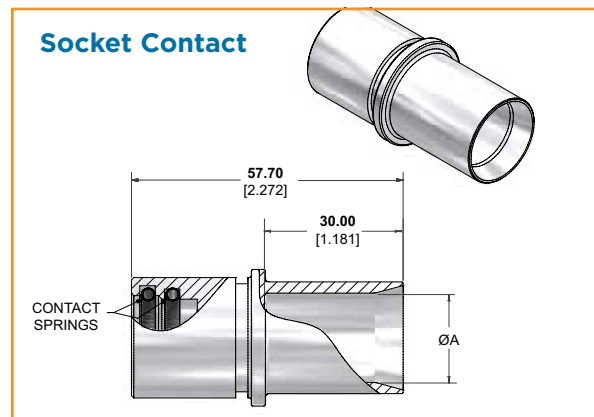

MATERIALS

- **Contact:** Silver-plated copper
- **Insulator:** PPS-GL40, UL94V-0

PERFORMANCE

- **Voltage Rating:** 1000 VAC / 1410 VDC
- **Current Rating:**
 - Shell Size 25: 1000A
 - Shell Size 23: 800A
 - Shell Size 21: 600A
 - Shell Size 19: 400A

Maximum Contact Size by Shell Size

Shell Size	Max. Crimp (CSA, mm ²)	
	Standard Cable	Fine Stranded Cable
19	70	70
21	120	95
23	185	150
25	240	185

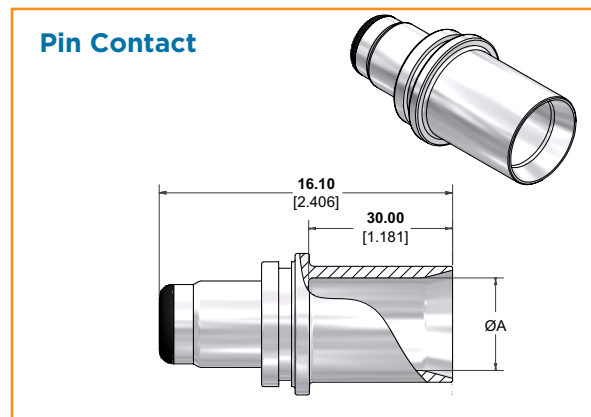

SERIES ————— PC04HP

SHELL SIZE ————— 25

CRIMP SIZE (CSA) ————— 185

CABLE TYPE ————— FS

CONTACT TYPE ————— P

MATERIAL ————— 5

FINISH ————— V

Legend:

- S** Standard
- FS** Fine Strand
- S** Socket
- P** Pin
- H3** 90°

MATERIAL — Copper

FINISH — Silver Plate

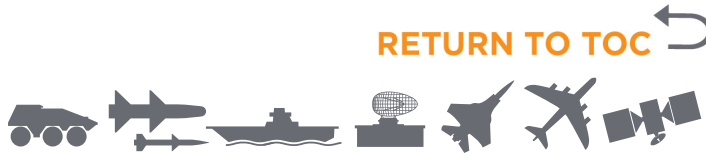

SAVES SPACE AND WEIGHT

- Standard aluminum alloy or lightweight composite shells
- Low profile backshells
- Long and short shell styles

RELIABLE PERFORMANCE

- Corrosion resistant
- Thread-on, pull-off interface
- Accommodates various shield braid termination methods

CONVENIENT

- Fewer parts help provide a simple, more reliable assembly
- Common interfacing capability for the operation and employment of stores
- Mating connector is standard MIL-DTL-38999 Series III receptacle

QUALIFIED

- MIL-DTL-38999/31 plug connectors (type 3, 4, and 5)
- ACT98 and commercial /29 composite versions also available
- Qualified to Eurofighter JN1034 also available

DEUTSCH Lanyard-Release Connectors



38999 Series III Plug Connectors for MIL-STD-1760 Aircraft/Store Electrical Interconnection Systems

DEUTSCH lanyard-release plugs are high-reliability electrical interconnections featuring common interfacing capability for the operation and employment of stores on aircraft.

Advanced aluminum and composite technology applied to mission-critical MIL-STD-1760 (AEIS) systems helps ensure higher performance in terms of corrosion resistance, weight savings, and durability.

Our lanyard-release connectors provide reliable interfaces for controlling and monitoring aircraft stores and other aircraft subsystems. With a variety of high-performance accessories, we help reduce assembly time, increase cost savings, and accommodate the severe environment of the MIL-STD-1760 system.

MATERIALS

- **Shell:** Composite or aluminum alloy
- **Finish:** Olive drab cadmium or electroless nickel
- **Lanyard Ring:** Black anodized aluminum alloy
- **Lanyard Cover:** PTFE, natural
- **Lanyard:** Aramid yarn, natural
- **Snap Rings and Wafer Spring:** Passivated stainless steel
- **Resilient Insert:** Silicone elastomer
- **Plastic Inserts:** Thermoplastic

ENVIRONMENTAL/MECHANICAL

- **Temperature:** -55°C to +175°C
- **Durability:** 500 mating cycles
- **Vibration:** As per MIL-DTL-38999
- **Thermal Shock:** As per MIL-DTL-38999

Contact TE for the latest information and design specifications.



SPACE AND WEIGHT SAVINGS

- Almost double the contact density of MIL-DTL-38999 connectors
- Lightweight materials

RUGGED

- Threaded anti-vibration coupling
- Scoop-proof interface
- Aggressive fluid resistance and dust ingress prevention

RELIABLE

- Fully sealed cable and mating interface
- EMI screening as per MIL-DTL-38999 Series III
- RFI mating interface band

VERSATILE

- Multiple keying options
- Various plating and material options
- Backshell or cable braid/boot rear feature that help eliminate need for backshell
- Rear-removable crimp and PCB contacts (consult TE for PCB details)

DEUTSCH Wildcat 38999-Style Connectors



Higher Contact Densities in a Familiar MIL-DTL-38999 Form Factor

Combine high reliability and high contact density in a familiar MIL-DTL-38999 format with Wildcat 38999 connectors. With higher contact density than mil-spec high-density inserts and nearly double the contact density of standard inserts, Wildcat 38999 connectors offer extreme temperature, vibration, and corrosion resistance, and durability of 500 mating cycles in a space-saving design.

The easy-grip coupling ring and triple-start thread make mating and unmating fast and simple.

A variety of material and plating options means versatile choices to match the demands of your application.

ELECTRICAL

- **Dielectric Withstand Voltage:** 1000 VAC
- **Current Rating:** 3 amps/contact

ENVIRONMENTAL

- **Temperature:**
 - 65°C to +175°C (cadmium)
 - 65°C to +200°C (nickel)
- **Durability:** 500 mating cycles min.
- **Vibration:** MIL-DTL-38999 Series III
- **Thermal Shock:** MIL-DTL-38999 Series III
- **Shock:** 300 g, 3 ms in 3 axes
- **Fluid resistance:** Withstands a wide range of military and aerospace fluids
- **Salt spray resistance:**
 - 500 hours (cadmium finish) per MIL-STD-1344 Method 100 B and NFC93422.
 - 48 hours (nickel finish)
- **Sealing:** Up to 30,000 m/100,000 ft. altitude



MATERIALS

- **Shell and Coupling Ring:** Aerospace grade aluminum alloy as standard
- **Plating:** Olive drab cadmium, RoHS electroless nickel, black zinc nickel (other finishes available on request)
- **Seals:** Fluorinated silicone
- **Insulators:** High-performance thermoplastic
- **Contacts:** Gold-plated machined copper alloy
- **Wire Size:** 28 to 24 AWG

Wildcat 38999-Style Connectors

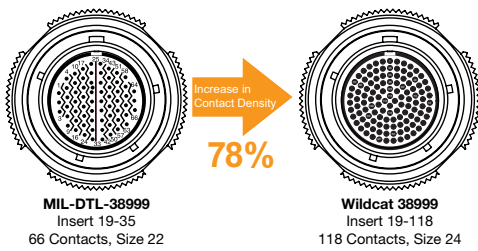

MIL-DTL-38999				DEUTSCH Wildcat 38999	
Standard Density Size 22D Contacts		High Density Size 23 Contacts		High Density Size 24 Contacts	
Insert	No. of Contacts	Insert	No. of Contacts	Insert	No. of Contacts
9-35	6	9-23	9	09-11	11
11-35	13	11-23	19	11-23	23
13-35	22	13-23	32	13-41	41
15-35	37	15-23	55	15-64	64
19-35	66	19-23	88	19-118	118

Square Flange Receptacle: Shell Type 0

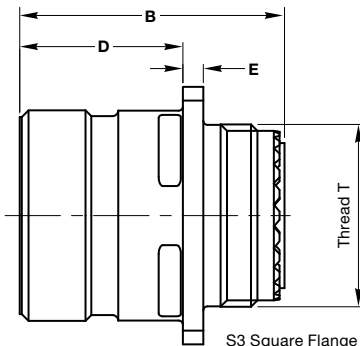
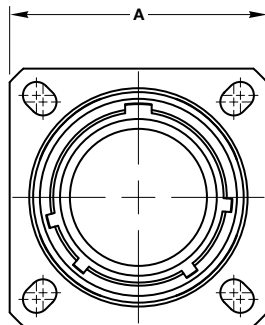

S3 Square Flange Receptacle
Shell Type 20

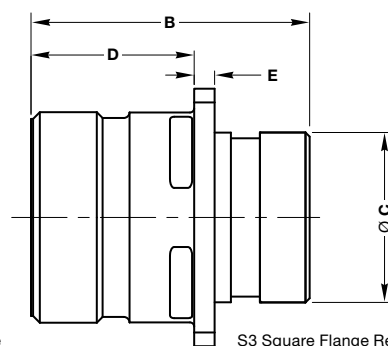

S3 Square Flange Receptacle
Shell Type 10

Square Flange Receptacle with Accessory Thread

Shell Size	A Max.	B Max.	D Max.	E Max.	Thread 'T'
09	24.00 .945				M12 x 1.0-6g
11	26.40 1.039	31.55 1.242	19.90 .783	2.50 .098	M15 x 1.0-6g
13	28.90 1.138				M18 x 1.0-6g
15	31.30 1.232				M22 x 1.0-6g

Millimeters Inches

Consult TE for further information on 19-118 connectors

Square Flange Receptacle with Knurled Rear

Shell Size	A Max.	B Max.	C Max.	D Max.	E Max.
09	24.00 .945		11.30 .445		
11	26.40 1.039	33.80 1.331	14.35 .565	19.90 .783	2.50 .098
13	28.90 1.138		17.50 .689		
15	31.30 1.232		20.65 .813		

Millimeters Inches

Consult TE for further information on 19-118 connectors



Wildcat 38999-Style Connectors

Square Flange Receptacle Panel Cutouts

Shell Size	ØX		Y	
	Front Mount	Rear Mount	Max.	Min.
09	13.11 .516	16.66 .656	18.26 .719	15.09 .594
11	15.08 .594	22.22 .875	20.26 .798	18.26 .719
13	19.05 .750	23.42 .922	23.01 .906	20.62 .812
15	23.01 .906	26.59 1.047	24.61 .969	23.01 .906

Millimeters Inches

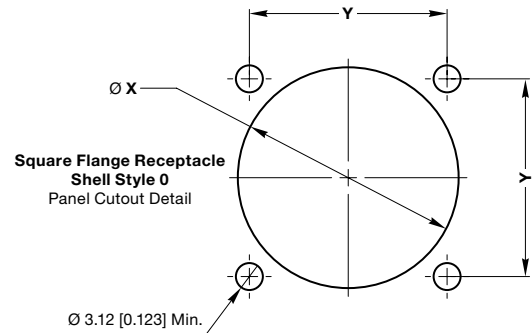

Jam Nut Receptacle: Shell Type 4

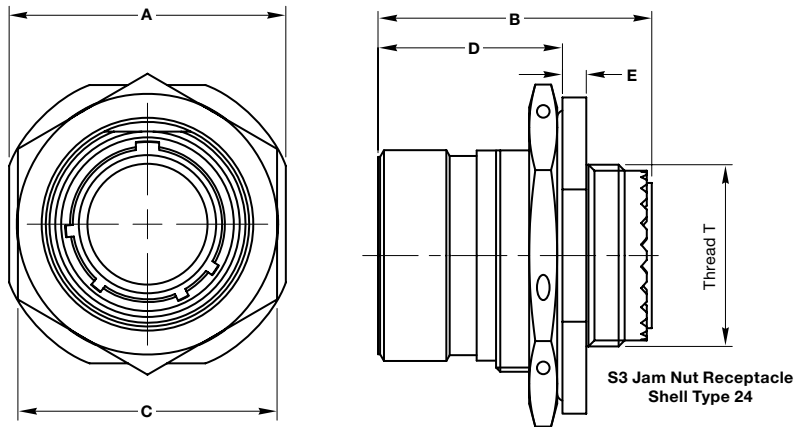

Shell Size	A Max.	B Max.	C Max.	D Max.	E Max.	Thread 'T'
09	27.20 1.071		23.25 .915			M12x1.0-6g
11	32.00 1.260	32.55 1.281	26.30 1.035	22.40 .882	2.95 .116	M15x1.0-6g
13	35.10 1.382		32.00 1.260			M18x1.0-6g
15	38.30 1.508		36.00 1.417			M22x1.0-6g

Millimeters Inches

Consult TE for further information on 19-118 connectors

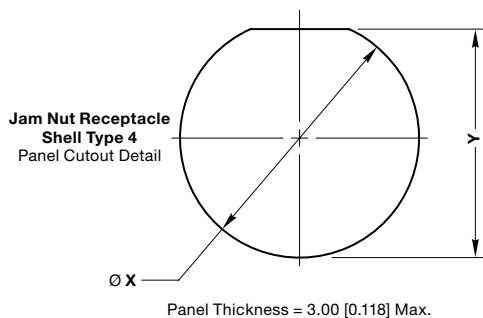



Wildcat 38999-Style Connectors

Jam Nut Receptacle Panel Cutouts

Shell Size	ØX (±.01)	Y (±.01)
09	17.80 .700	16.89 0.665
11	20.98 .826	19.43 .765
13	25.68 1.011	24.16 .951
15	28.90 1.138	27.43 1.080

Millimeters Inches

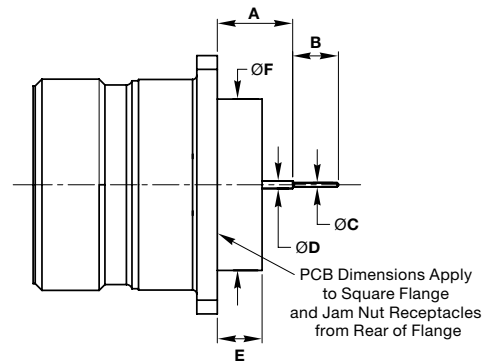

PCB Tail Dimensions

Layout	Part No. Option Code	Shell Accessory	Part No.		A		B Max.	ØC Max.	ØD Max.	E Max.	ØF Max.	
			Pins	Sockets	Max.	Min.					Shell Size	SØ Max.
09-11 11-23 13-41 15-64 19-118	-151	W320	611624-31	611625	11.73 .462	10.73 .422	5.55 .219	.60 .024	1.00 .039	5.74 .226	09	11.07 .436
	-151	W324	611556-31	611627	9.73 .383	8.73 .344	5.55 .219	.60 .024	1.00 .039	5.74 .226	11	14.33 .564
	-151	W330	Potted	Potted	9.73 .383	8.73 .344	5.55 .219	.60 .024	1.00 .039	5.74 .226	13	17.42 .686
	-151	W334	Potted	Potted	6.73 .265	5.73 .226	5.55 .219	.60 .024	1.00 .039	5.74 .226	15	20.57 .810

Millimeters Inches

Free Plug: Shell Type 6

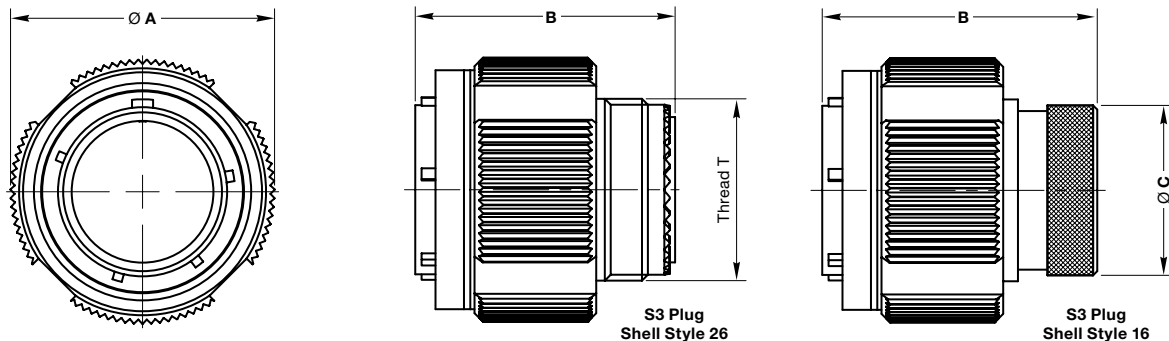

Plug with Accessory Thread

Shell Size	ØA Max.	B Max.	Thread 'T'
09	21.30 .839	31.10 1.224	M12x1.0-6g
11	23.75 .935		M15x1.0-6g
13	29.10 1.146		M18x1.0-6g
15	32.30 1.272		M22x1.0-6g

Millimeters Inches

Consult TE for further information on 19-118 connectors

Plug with Knurled Rear

Shell Size	ØA Max.	B Max.	ØC Max.
09	21.30 .839	33.30 1.311	11.30 .445
11	23.75 .935		14.35 .565
13	29.10 1.146		17.50 .689
15	32.30 1.272		27.00 1.063

Millimeters Inches

Consult TE for further information on 19-118 connectors



Wildcat 38999-Style Connectors

CONTACTS

Contact		Current Rating	Wire Size (AWG)	Conductor		Wire Sealing Range	
Pin	Socket			Min. Ø	Max. Ø	Min. Ø	Max. Ø
605719-31	605721	3 A	24-28	.254 .010	.511 .020	.600 .024	.96 .038

Millimeters Inches
Filler Plug: Part No. 800300-24

TOOLING

Ins/Ext Tool	Crimp Tool	Positioner	
		Pin	Socket
605837	M22520/ 2-01	610286	610287

Contact Arrangement

(Viewed from the mating face of a connector with male (pin) contacts)

Shell Size 09

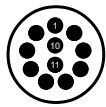

09-11

Shell Size 11

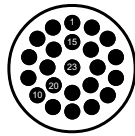

11-23

Shell Size 13

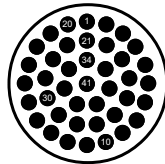

13-41

Shell Size 15

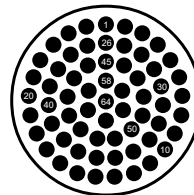

15-64

Shell Size 19

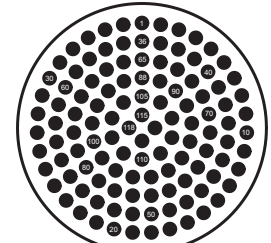

19-118

ACCESSORIES

Protective Caps and Backshells

Wildcat 38999 connectors are compatible with MIL-DTL-38999 Series III style backshells and procaps or equivalent.

Raychem Heat-Shrink Boots

Shell Size	Straight Boot	90° Boot
09	202K121	222K121
11	202K132	222K121
13	202K142	222K132
15	202K142	222K142
19	202K153	222K152

CRES-Lock Bandstraps



Easy to Use

- Quick, easy, cost-effective and reliable termination of braided shielding

High Performance

- Low profile, one-piece design helps eliminate EMI leakage paths

Rugged

- Shock, vibration and environmental performance to help meet aerospace and defense requirements



Wildcat 38999-Style Connectors

ORDERING INFORMATION

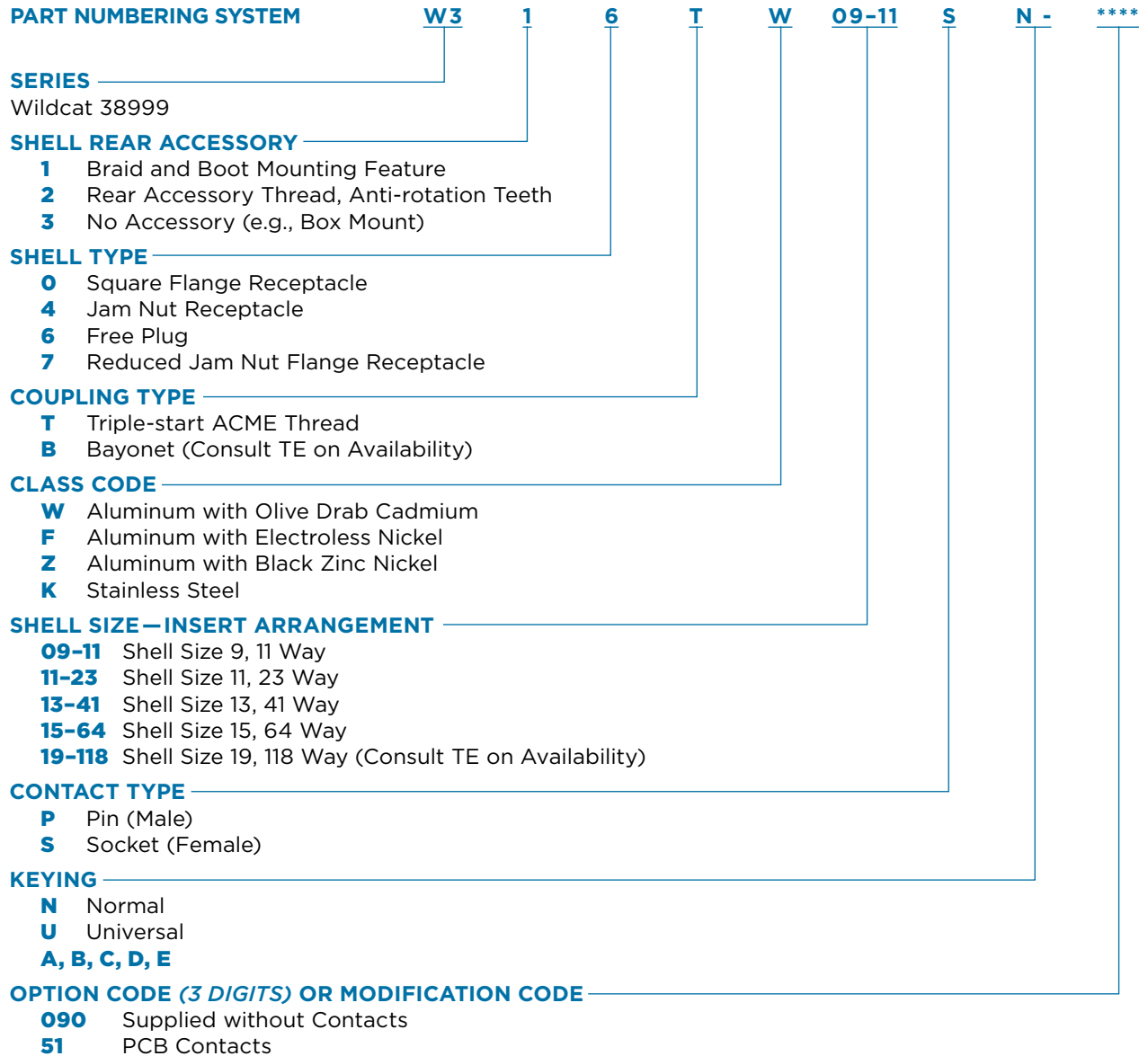

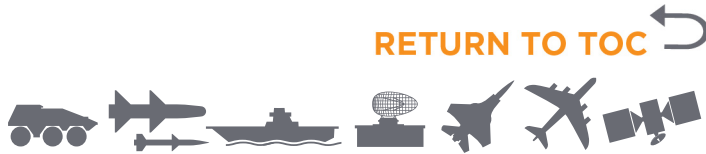
**VERSATILE**

- Medium and high-density arrangements
- 12 shell sizes and up to 128 contacts
- 100% scoop proof design

RELIABLE

- Elastomer interface and wire seals
- RFI fingers at mating interface and 360° backshell
- Hard face socket insert
- Contact retention mechanism integral to insert

CONVENIENT

- Simple assembly techniques with standard tooling
- Standard MIL-C-39029 contacts
- Positive bayonet locking serrations

38999-Style HDJ Series Connectors

**DEUTSCH HDJ/JN1003 Medium and High Density Connectors**

The HDJ Series connectors are bayonet coupling connectors specifically designed for Eurofighter use. The range comprises plugs, receptacles, and cable accessories.

The series is intermateable and intermountable with connectors conforming to LN29729, EN3372, VG 96912 and the DEUTSCH AS range. The connectors are qualified in accordance with J 62.017.

The connectors are based on MIL-DTL-38999 Series I coupling interface lengths and Series II diameters.

Specifications

MATERIALS

- **Shell:** Aluminum alloy, plated olive drab cadmium
- **RFI Ring:** Beryllium copper, plated nickel/cadmium
- **Inserts:** Thermoplastic and fluorinated silicone elastomer
- **Contacts:** Copper alloy, plated gold

MECHANICAL

- **Vibration:** Per J62.017 para. 2.11
- **Durability:** 500 mating cycles

ENVIRONMENTAL

- **Service Temperature:** -55° C to +175° C
- **Thermal Shock:** As per J62.017 para. 2.4
- **Sealing:** Up to 30,000 m (100,000 ft.) altitude
- **Salt Spray Resistance:** per MIL-DTL-38999



38999-Style HDJ Series Connectors

ELECTRICAL

- **Insulation Resistance:** $\geq 100,000 \text{ M}\Omega$ @ 20°C
- **Contact Current Rating:**
 - Size 22: 5 A
 - Size 20: 7.5 A
 - Size 16: 13 A
 - Size 12: 23 A
 - Size 8

Dielectric Withstand Voltage

Rating Class	Dielectric Withstand Voltage (VAC _{rms})	
	Sea Level	22,000 m (70,000 ft.)
M	1300	800
N	1000	600
I	1800	1000
II	2300	1000

Part Numbering

DEUTSCH Series

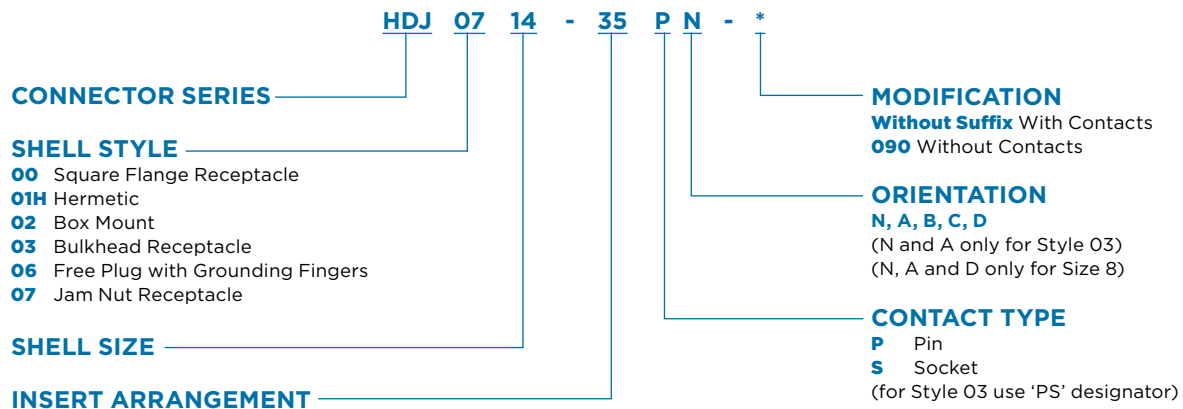

Part Numbering

Eurofighter Series

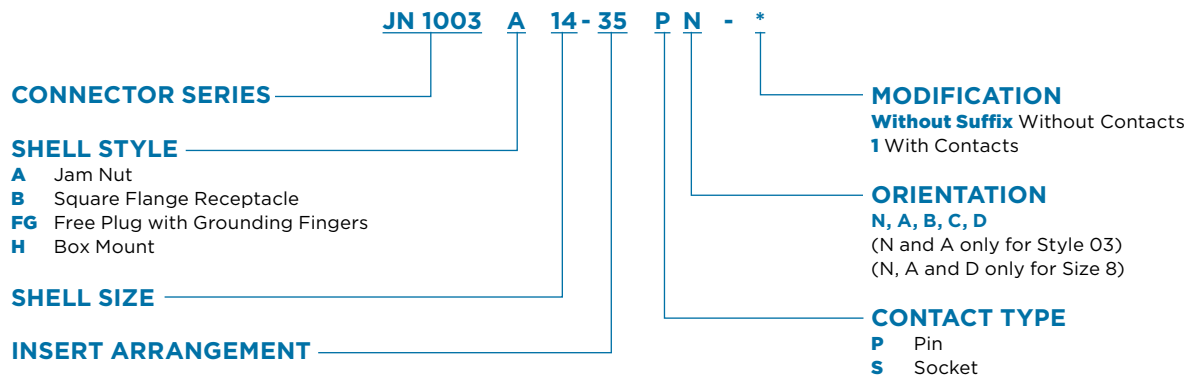



38999-Style HDJ Series Connectors

Square Flange Receptacle - Shell Style OO (JN 1003 Style B)

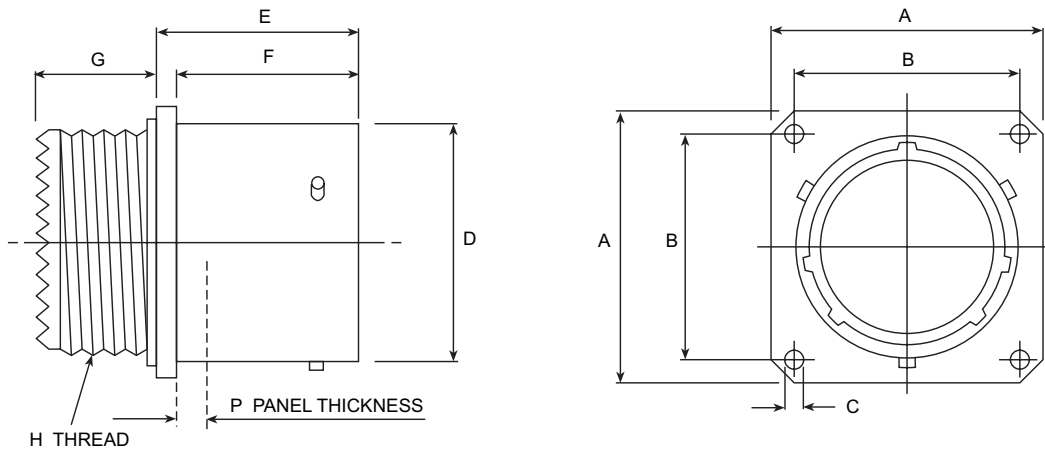

Shell Size	A ±0.40 (±0.016)	B ±0.13 (±0.005)	C ±0.10 (±0.004)	D +0/-0.13 (+0/-0.005)	E +0.15 (+0.016) Max.	F +0/-0.13 (+0/-0.005)	G Max.	H Thread UNEF Class 2a	P Max.
08	20.62 0.812	15.10 0.594		12.00 0.472				0.4375 - 28	
10	23.83 0.938	18.30 0.720		15.00 0.591				0.5625 - 24	
12	26.19 1.031	20.60 0.811		19.05 0.750				0.6875 - 24	
14	28.57 1.125	23.00 0.906		22.22 0.875		16.05 0.632		0.8125 - 20	
16	30.96 1.219	24.60 0.969	3.20 0.126	25.40 1.000	18.21 0.717		14.00 0.551	0.9375 - 20	3.00 0.118
18	33.32 1.312	27.00 1.063		28.57 1.125				1.0625 - 18	
20	36.53 1.438	29.40 1.157		31.75 1.250				1.1875 - 18	
22	39.67 1.562	31.80 1.252		34.92 1.375		15.29 0.602		1.3125 - 18	
24	42.90 1.689	34.90 1.374	3.70 0.146	38.10 1.500				1.4375 - 18	2.26 0.089

Millimeters Inches

Shell Size	08	10	12	14	16	18	20	22	24
W ± 0.2	13.7 0.539	16.9 0.665	21.0 0.827	24.2 0.953	27.3 1.075	30.5 1.201	33.7 1.327	36.9 1.453	40.0 1.575
Z ± 0.2	15.1 0.594	18.3 0.720	20.6 0.811	23.0 0.906	24.6 0.969	27.0 1.063	29.4 1.157	31.8 1.252	34.9 1.374
Y	28.0 1.102	31.0 1.220	36.0 1.417	41.0 1.614	43.0 1.693	46.0 1.811	53.0 2.087	58.0 2.283	61.0 2.402

Millimeters Inches

Panel Cutout

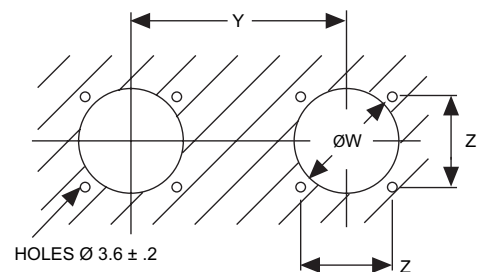



38999-Style HDJ Series Connectors

Jam Nut Receptacle - Shell Style 07 (JN 1003 Style A)

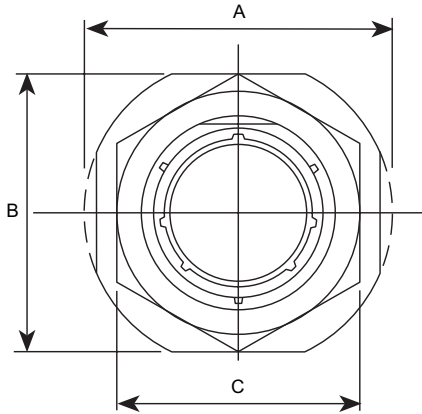
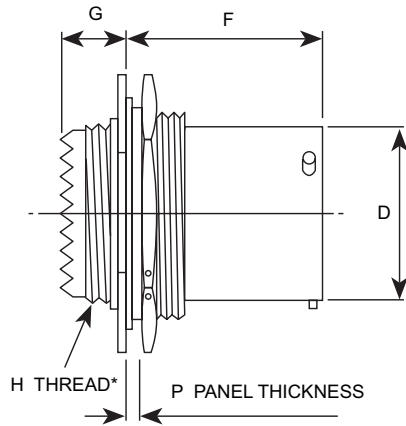

*H Thread VG 96912 Style - Consult TE for availability.

Shell Size	A Max.	B ±0.41 (±0.016)	C ±0.43/-0.41 (±0.017/-0.016)	D +0/-0.13 (+0/-0.005)	F +0.13 (+0.005)	G Max.	P	H Thread UNEF Class 2a
08	27.38 1.078	23.83 0.938	19.05 0.750	12.00 0.472				0.4375 - 28
10	30.56 1.203	26.97 1.062	22.22 0.875	15.00 0.591				0.5625 - 24
12	35.33 1.391	31.75 1.250	26.97 1.062	19.05 0.750				0.6875 - 24
14	38.51 1.516	34.92 1.375	30.18 1.188	22.22 0.875				0.8125 - 20
16	41.68 1.641	38.10 1.500	33.32 1.312	25.40 1.000	23.24 0.915	14.10 0.555	3.20 0.126 Max	0.9375 - 20
18	44.86 1.766	41.27 1.625	36.53 1.438	28.57 1.125			1.60 0.063 Max	1.0625 - 18
20	49.61 1.953	46.02 1.812	39.67 1.562	31.75 1.250				1.1875 - 18
22	52.78 2.078	49.23 1.938	42.88 1.688	34.92 1.375				1.3125 - 18
24	55.96 2.203	52.37 2.062	46.02 1.812	38.10 1.500				1.4375 - 18

Millimeters Inches

Panel Cutout

Shell Size	08	10	12	14	16	18	20	22	24
W ± 0.10	14.53 0.572	17.7 0.697	22.5 0.886	25.7 1.012	28.83 1.135	32.01 1.260	35.18 1.385	38.36 1.510	41.53 1.635
Z ± 0.2	13.62 0.536	16.79 0.661	21.0 0.827	24.08 0.948	27.23 1.072	30.41 1.197	33.58 1.322	36.95 1.455	39.93 1.572
Y	28.0 1.102	31.0 1.220	36.0 1.417	41.0 1.614	43.0 1.693	46.0 1.811	53.0 2.087	58.0 2.283	61.0 2.402

Millimeters Inches

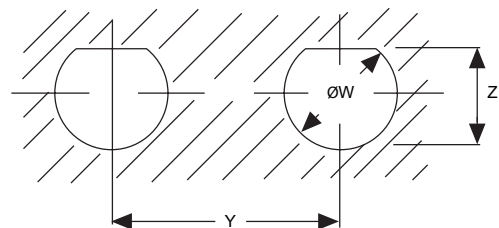



38999-Style HDJ Series Connectors
 Box Mount-Shell Style 02 (JN 1003 Style H)

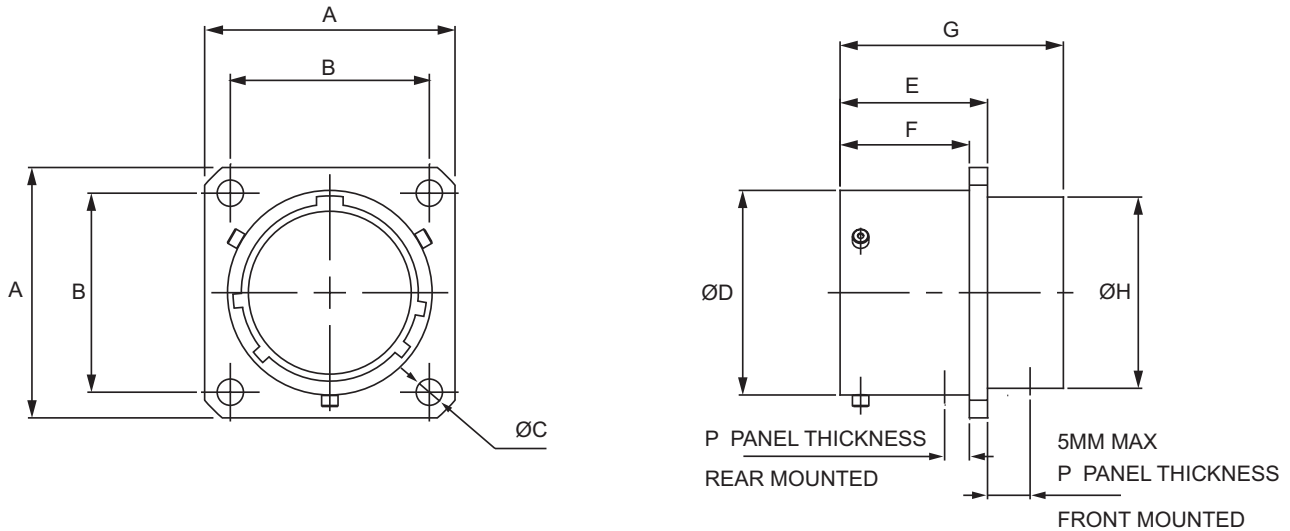

Shell Size	A ±0.40 (±0.016)	B ±0.13 (±0.005)	ØC Min.	ØD +0.00/-0.13 (+0.00/-0.005)	E +0.15 (+0.016) Max.	F +0.00/-0.13 (+0.00/-0.005)	G Max.	ØH Max.	P Max.
08	20.62 0.812	15.10 0.594		12.00 0.472				11.91 0.469	
10	23.83 0.938	18.30 0.720		15.00 0.591				15.09 0.594	
12	26.19 1.031	20.60 0.811		19.05 0.750				18.26 0.719	
14	28.57 1.125	23.00 0.906		22.22 0.875		16.05 0.632		21.44 0.844	
16	30.96 1.219	24.60 0.969	3.20 0.126	25.40 1.000	18.21 0.717		27.65 1.089	24.61 0.969	3.00 0.118
18	33.32 1.312	27.00 1.063		28.57 1.125				27.38 1.078	
20	36.53 1.438	29.40 1.157		31.75 1.250				30.56 1.203	
22	39.67 1.562	31.80 1.252		34.92 1.375				33.73 1.328	
24	42.90 1.689	34.90 1.374	3.70 0.146	38.10 1.500		15.29 0.602	28.72 1.131	36.91 1.453	2.26 0.089

Millimeters Inches



38999-Style HDJ Series Connectors

Solder Mount-Shell Style 01H (JN 1003 Style E Type)*

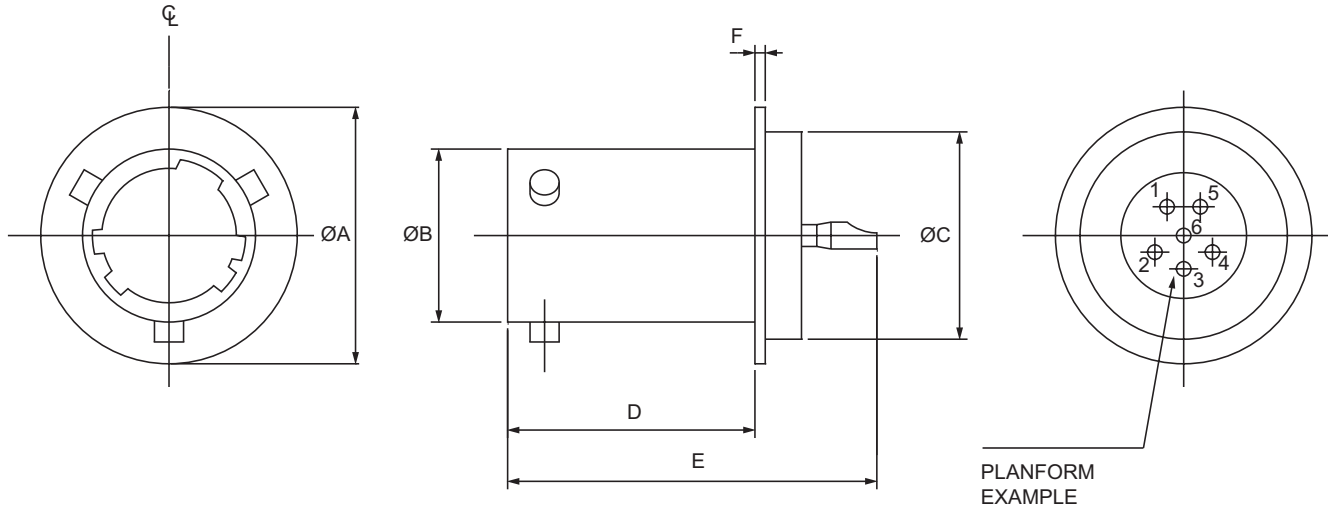

Shell Size	ØA ±0.05 (±0.002)	B +0.00/-0.16 (+0.00/-0.006)	C ±0.05 (±0.002)	D Max.	E ±1.16 (±0.046)	F Max.
08	17.45 0.687	12.00 0.472	14.20 0.559			
10	20.24 0.797	15.00 0.591	16.99 0.669			
12	23.01 0.906	19.05 0.750	19.76 0.778			
14	26.19 1.031	22.22 0.875	22.94 0.903	17.18 0.676	26.29 1.035	
16	29.36 1.156	25.40 1.000	26.11 1.028			0.76 0.030
18	32.54 1.281	28.57 1.125	29.29 1.153			
20	34.92 1.375	31.75 1.250	31.67 1.247			
22	38.10 1.500	34.92 1.375	34.85 1.372	17.19 0.677	26.30 1.035	
24	41.27 1.625	38.10 1.500	38.02 1.497			

Millimeters Inches

*Shell Styles '01H' and '03' are not qualified to JN1003



38999-Style HDJ Series Connectors

Through Bulkhead Receptacle Shell Style 03 (JN 1003 Style J Type)*

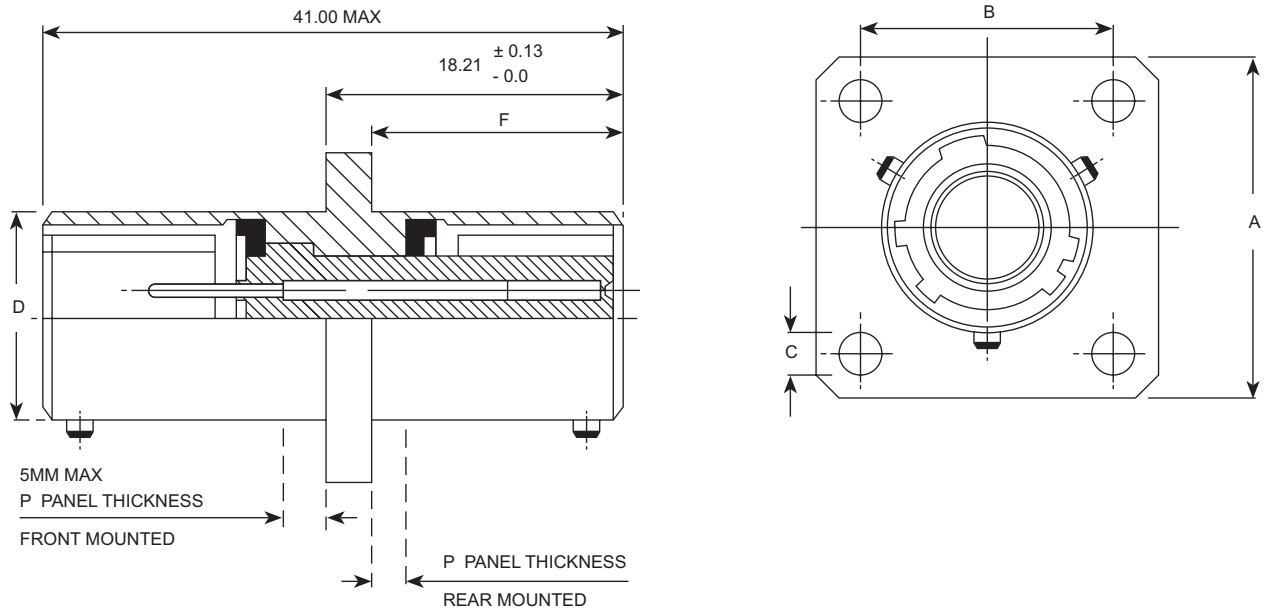

Shell Size	A +0.40 (±0.016)	B ±0.13 (±0.005)	C ±0.10 (±0.004)	D +0/-0.13 (+0/-0.005)	F +0/-0.13 (+0/-0.005)	P Max.
08	20.62 0.812	15.10 0.594		12.00 0.472		
10	23.83 0.938	18.30 0.720		15.00 0.591		
12	26.19 1.031	20.60 0.811		19.05 0.750	16.05 0.632	
14	28.57 1.125	23.00 0.906	3.20 0.126	22.22 0.875		3.00 0.118
16	30.96 1.219	24.60 0.969			25.40 1.000	
18	33.32 1.312	27.00 1.063		28.57 1.125		
20	36.53 1.438	29.40 1.157		31.75 1.250		
22	39.67 1.562	31.80 1.252		34.92 1.375	15.29 0.602	
24	42.90 1.689	34.90 1.374	3.70 0.146	38.10 1.500		2.26 0.089

Millimeters Inches



38999-Style HDJ Series Connectors

Plugs

Plug with Grounding Fingers - Shell Style 06 (JN 1003 Style FG)

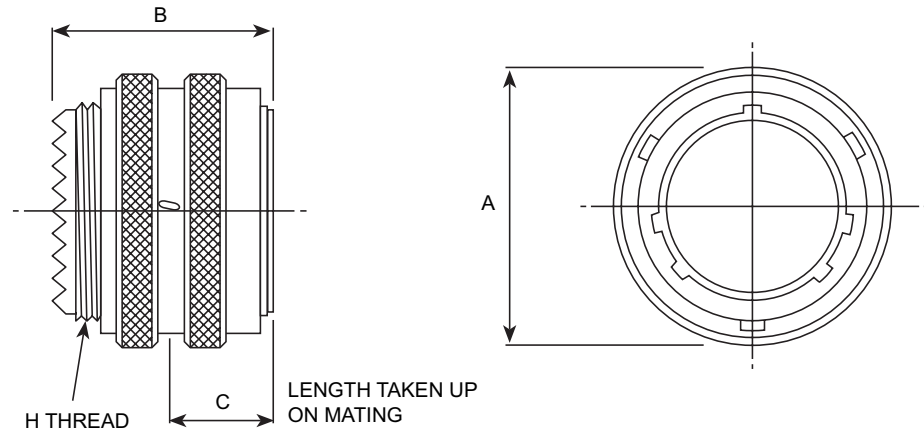

Shell Size	A Max.	B Max.	C Max.	H Thread UNEF Class 2a
08	18.64 0.734			0.4375 - 28
10	21.44 0.844			0.5625 - 24
12	25.81 1.016			0.6875 - 24
14	28.98 1.141	30.00 1.181		0.8125 - 20
16	32.13 1.265		15.00 0.591	0.9375 - 20
18	35.33 1.391			1.0625 - 18
20	38.10 1.500			1.1875 - 18
22	41.27 1.625			1.3125 - 18
24	44.45 1.750	31.50 1.240		1.4375 - 18

Millimeters Inches



38999-Style HDJ Series Connectors

Accessories

Protective Cap, Receptacle (JN 1003 Styles MA/MB)*

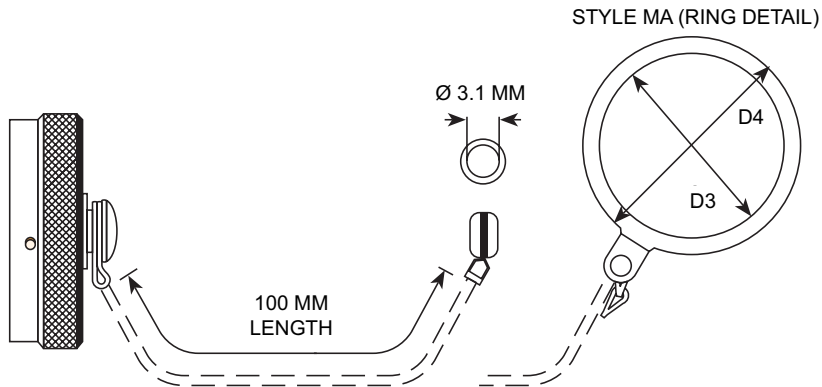

TE DEUTSCH Part No.	Eurofighter Ref.	Shell Size
HDJ12 - **	JN1003MB**	**
HDJ13 - **	JN1003MA**	**

Shell Size	D3	D4
08	14.6 0.575	21.95 0.864
10	17.8 0.701	26.77 1.054
12	22.5 0.886	31.55 1.242
14	25.7 1.012	36.83 1.450
16	28.9 1.138	40.31 1.587
18	32.1 1.264	43.18 1.700
20	35.2 1.386	46.36 1.825
22	38.0 1.496	49.19 1.937
24	41.6 1.638	52.71 2.075

Millimeters Inches

*Protective caps are not qualified to JN1003



38999-Style HDJ Series Connectors

Accessories

Protective Cap, Plug (JN 1003 Style MF)

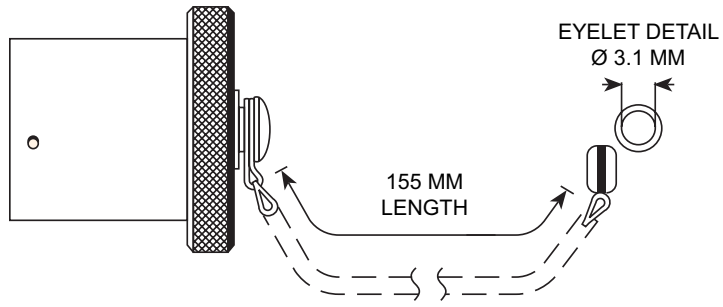

TE DEUTSCH Part No.	Eurofighter Ref.	Shell Size
HDJ11 - **	JN1003MF**	**



38999-Style HDJ Series Connectors

Accessories

Dummy Stowage (JN 1003 Style R)

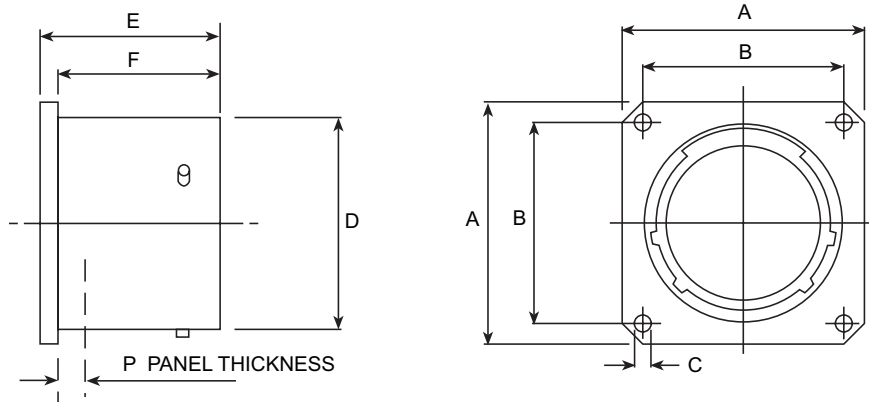

TE DEUTSCH Part No.	Eurofighter Ref.	Shell Size
HDJ10 - **	JN1003R**	**

Shell Size	A +0.40 (+0.016)	B ±0.13 (±0.005)	C ±0.10 (±0.004)	D +0/-0.13 (+0/-0.005)	E +0.15 (+0.006)	F +0/-0.13 (+0/-0.005)	P Max.
08	20.62 0.812	15.10 0.594		12.00 0.472			
10	23.83 0.938	18.30 0.720		15.00 0.591			
12	26.19 1.031	20.60 0.811		19.05 0.750		16.05 0.632	
14	28.57 1.125	23.00 0.906	3.20 0.126	22.22 0.875			3.00 0.118
16	30.96 1.219	24.60 0.969		25.40 1.000	18.21 0.717		
18	33.32 1.312	27.00 1.063		28.57 1.125			
20	36.53 1.438	29.40 1.157		31.75 1.250			
22	39.67 1.562	31.80 1.252		34.92 1.375		15.292 0.602	
24	42.90 1.689	34.90 1.374	3.70 0.146	38.10 1.500			2.266 0.089

Millimeters Inches



Insert Arrangements

SIZE 8

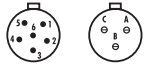

08-35 6#22D (M)
08-98 3#20 (I)

SIZE 10

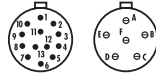

10-35 13#22D (M)
10-98 6#20 (I)

SIZE 12



12-04 4#16 (I)
12-35 22#22D (M)
12-98 10#20 (I)

SIZE 14



14-19 19#20 (I)
14-35 37#22D (M)
14-97 8#20 4#16 (I)

SIZE 16

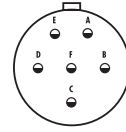

16-06 6#12 (I)

SIZE 16

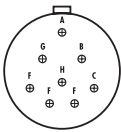

16-08 8#16 (II)

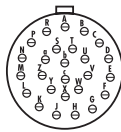

16-26 26#20 (I)

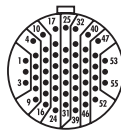

16-35 55#22D (M)

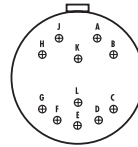

18-11 11#16 (II)

SIZE 18

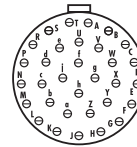

18-32 32#20 (I)

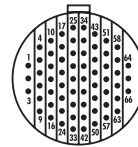

18-35 66#22D (M)

SIZE 20

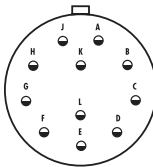

20-11 11#12 (I)

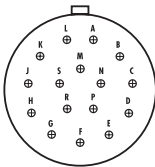

20-16 16#16 (II)

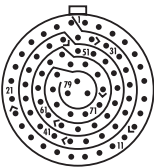

20-35 79#22D (M)

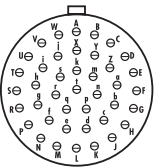

20-41 41#20 (I)

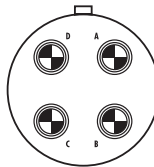

20-75 4 TWINAX #8 (M)

SIZE 22

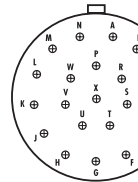

22-21 21#16 (II)

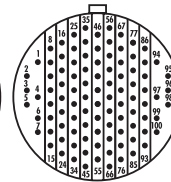

22-35 100#22D (M)

SIZE 22

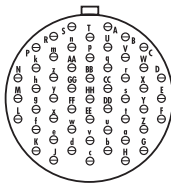

22-53 53#20 (I)

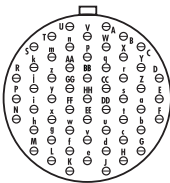

22-55 55#20 (I)

SIZE 24

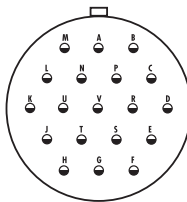

24-19 19#12 (I)

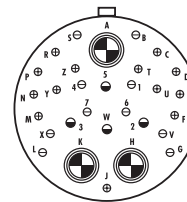

24-20 10#20 13#16 4#12
3 TWINAX #8 (N)

SIZE 24

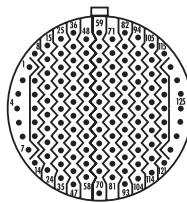

24-35 128#22D (M)

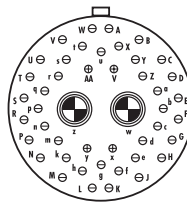

24-46 40#20 4#16 2#8 COAX (I)

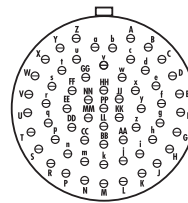

24-61 61#20 (I)



APPLICATION FLEXIBILITY

- Available in various shell sizes: 9 (1Q1), 17 (2Q2), 19 (4Q4), 21 (4Q4) and 25 (8Q8)
- Accepts standard backshells

RUGGED

- Designed for use with wire seal boots for sealing and optimized alignment
- Front metal-shell design provides a full ground plane

SAVES WEIGHT

- Lightweight composite rear shell available in size 19

Quadrax Connectors



Custom 38999-Style Series III Connectors

TE Connectivity (TE) offers the highly versatile Quadrax multi-signal contact system consisting of two differential pairs (matched impedance) used with quadaxial Ethernet and Fiber Channel cables.*

Specifications

ELECTRICAL

- **Bandwidth:** Up to 3 GHz
- **Data Rate:** >2 Gb/s
- **Characteristic Impedance:** 100Ω (± 10Ω)
- **Maximum Voltage Rating:** 500 V_{rms} @ sea level
- **Dielectric Withstanding Voltage:**
1000 VAC_{rms} between any two contacts @ sea level
500 VAC_{rms} between any contact and outer shell @ sea level

MATERIALS

- **Contacts, Shells, Ferrules:**
Copper alloy with gold over nickel finish
One-piece thermoplastic dielectric

MECHANICAL/ENVIRONMENTAL

- **Maximum Mating Force:** 2.75 lbf.
- **Minimum Unmating Force:** 1.25 lbf.
- **Durability:** 500 mating cycles

APPLICATIONS

- Commercial Avionics Systems
- Aircraft Data Networks
- Military Communications
- In-Flight Entertainment
- Space

STANDARDS AND TEST REPORTS

- **TE Product Specification:** 108-2199
- **TE Test Reports:** 501-660
- **Application Specifications:** 114-13163

*Metal ground plane only

The connectors in this section are unique for metal ground plane Quadrax applications and are only inter-mateable with connectors of the opposite gender in this catalog section.



Custom 38999-Style Series III Quadrax Connectors

Shell Size	Part No.	Type	Description
9	1738916	Receptacle	1Q1, FR-FR, Jam Nut Style, with PC Tail Contacts
	1811184	Receptacle	1Q1, FR-FR, PCB Mount with Stand-offs and PC Tail Contacts
	2157694	Receptacle	1Q1, RR-RR, Jam Nut Style
	1877384	Plug	1Q1, RR-RR
17	1877774	Receptacle	2Q2, RR-RR
	2157455	Receptacle	2Q2, FR-FR, PCB Mount
	2157695	Receptacle	2Q2, RR-RR, Jam Nut Style
	1877775	Plug	2Q2, RR-RR
19	1738974	Receptacle	4Q4, FR-FR, without PC Tail Contacts
	1877732	Receptacle	4Q4, FR-FR, with PC Tail Contacts
	1811901	Receptacle	4Q4, RR-RR
	2157696	Receptacle	4Q4, RR-RR, Jam Nut Style
	1811902	Plug	4Q4, RR-RR
	2221849	Receptacle	4Q4, with Threaded Mounting Holes
21	1954355	Plug	4Q4, RR-RR
	1954353	Receptacle	4Q4, FR-FR, with PC Tail Contacts
	2101633	Receptacle	4Q4, RR-RR, Flange Mount
23	1877921	Plug	6Q6, RR-RR
	1954577	Receptacle	6Q6, RR-RR
	2221366	Receptacle	6Q6, FR-FR, with PC Tail Contacts
25	1811928	Plug	8Q8, RR-RR
	1811927	Receptacle	8Q8, RR-RR
	2157628	Receptacle	8Q8, RR-RR, Jam Nut Style
	2101395	Receptacle	8Q8, FR-FR, with PC Tail Contacts
	1996625	Receptacle	8Q8, FR-FR, PCB Mount with Stand-offs and PC Tail Contacts

See TE Customer Drawing for finish options

Custom 38999-Style Series III Quadrax Connectors

**Plug, Shell Size 9 Single Quadrax, RR-RR
Part No. 1877384**

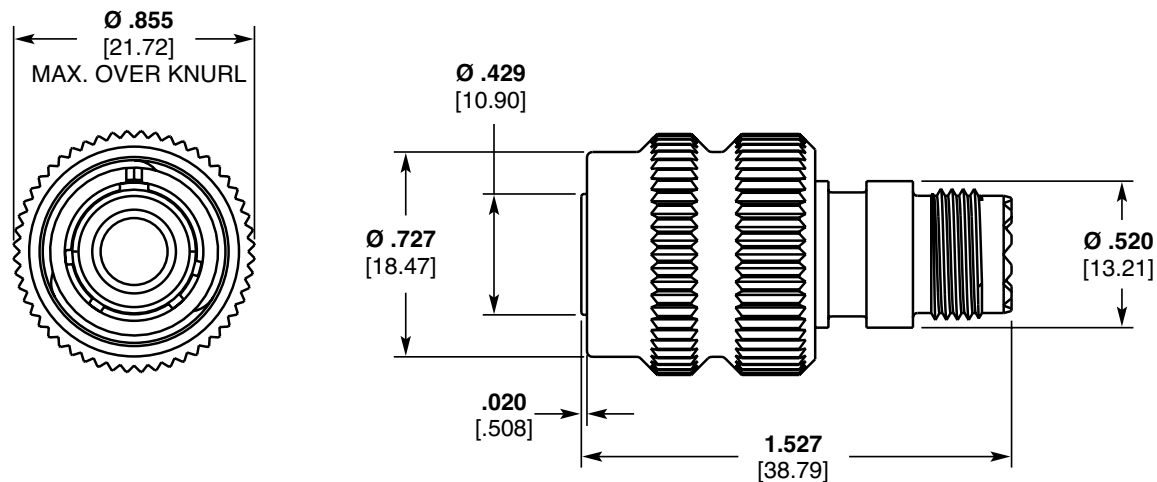



Custom 38999-Style Series III Quadrax Connectors

Receptacle, Shell Size 9, 38999 Style Single Quadrax, FR-FR Jam Nut Style
Part No. 1738916

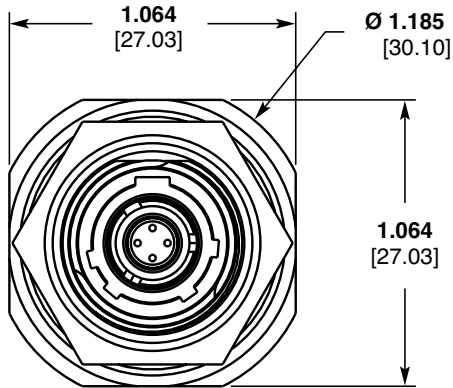

Contacts sold separately (unless noted)

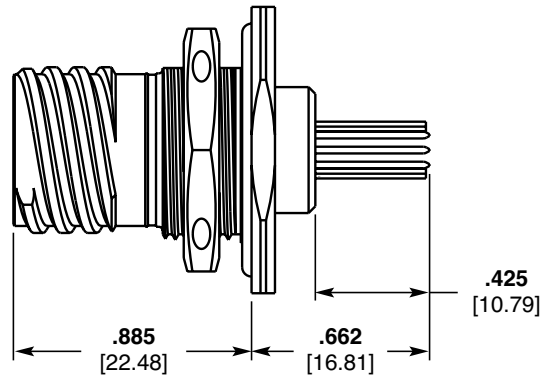

Receptacle, Shell Size 9, Single Quadrax, FR-FRPCB Mount with Stand-offs
Part No. 1811184 (with PC tail contacts)

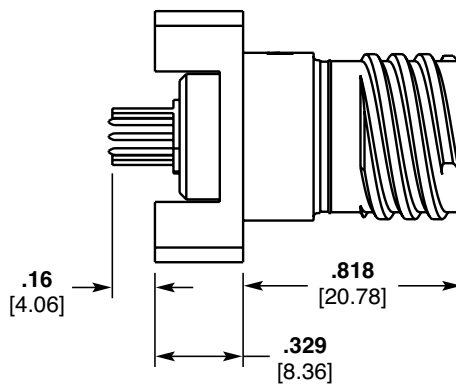
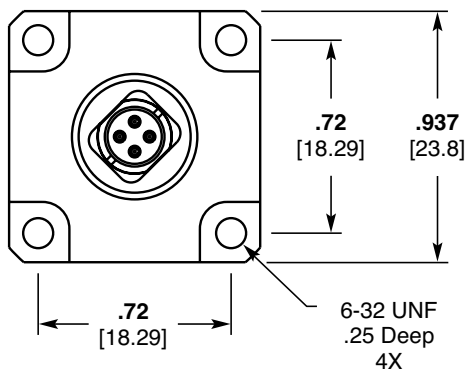

Receptacle, Shell Size 9, Single Quadrax, RR-RR Jam Nut Style
Part No. 2157694

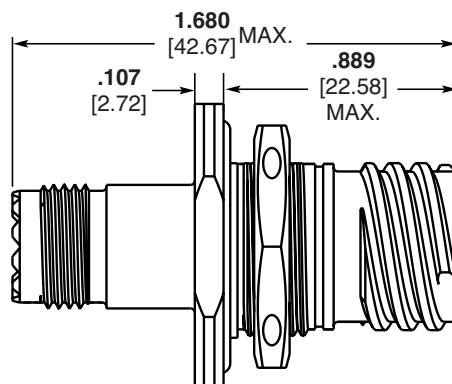
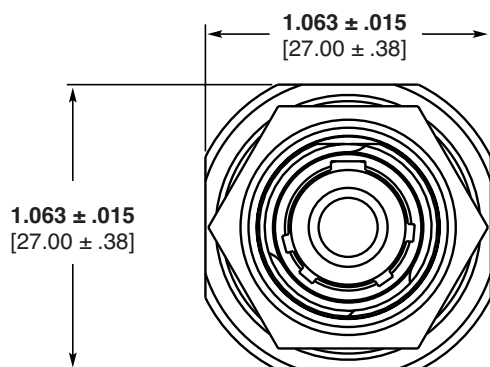



Custom 38999-Style Series III Quadrax Connectors

Plug, Shell Size 17, Arrangement 2Q2, RR-RR
Part No. 1877775

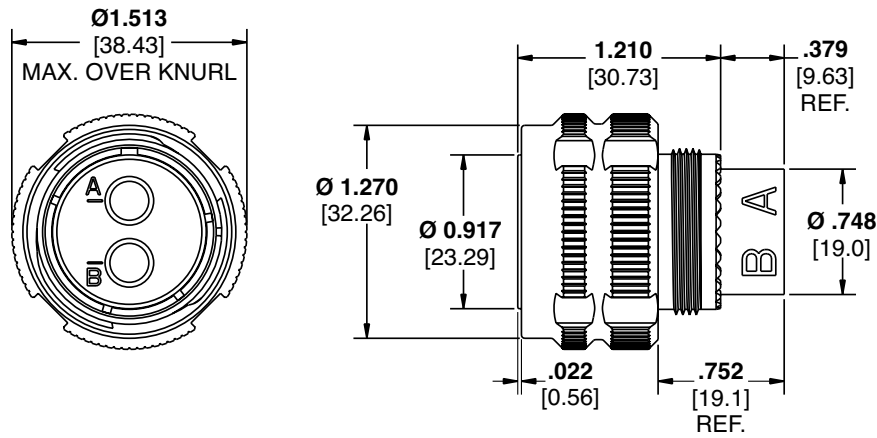

Receptacle, Shell Size 17, Arrangement 2Q2, RR-RR
Part No. 1877774

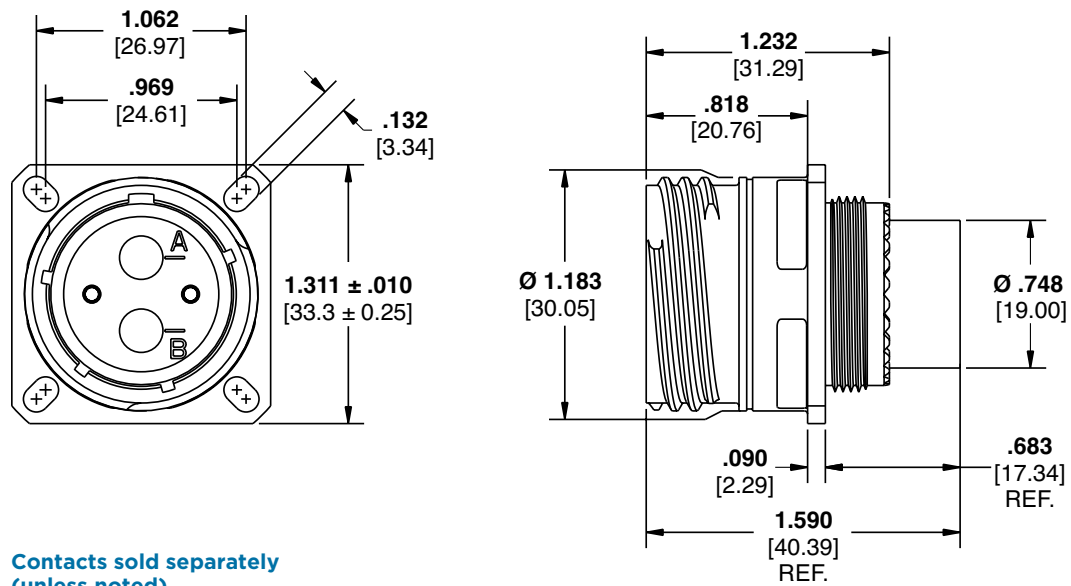

Contacts sold separately
(unless noted)



Custom 38999-Style Series III Quadrax Connectors

Receptacle, Shell Size 17, Arrangement 2Q2, FR-FR
Part No. 2157455

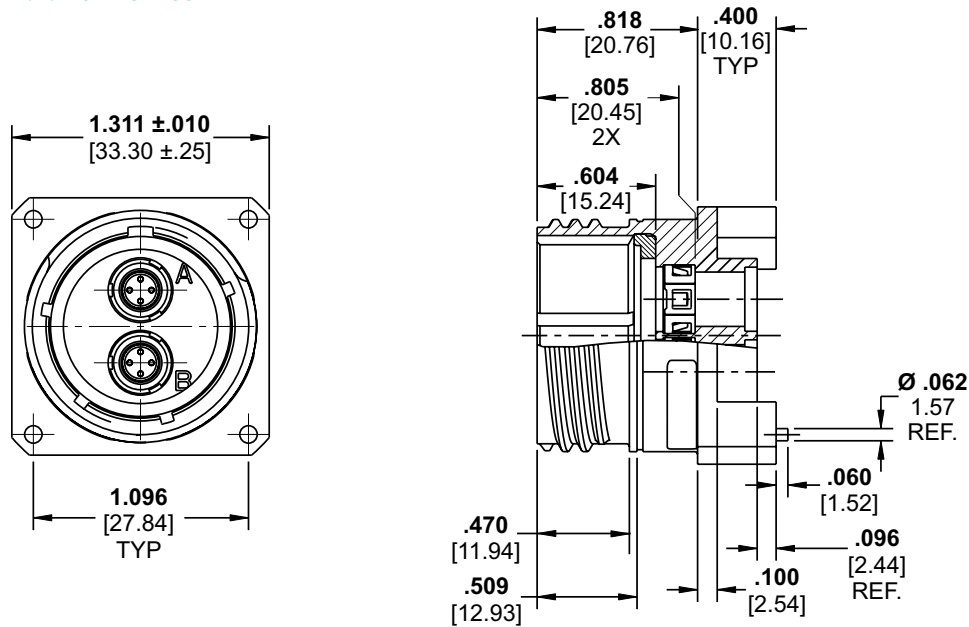

Receptacle, Shell Size 17, Arrangement 2Q2, RR-RRJam Nut Style
Part No. 2157695

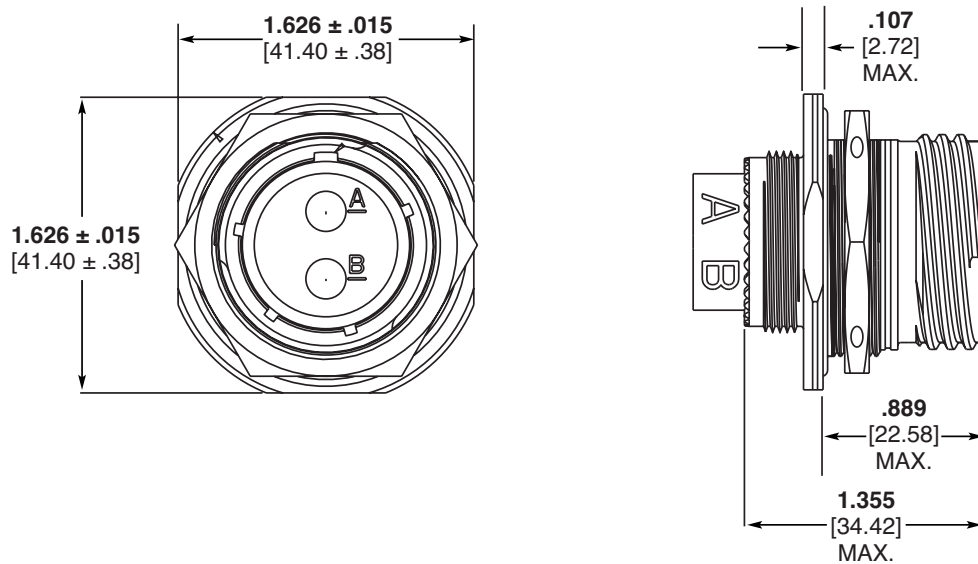



Custom 38999-Style Series III Quadrax Connectors

Plug, Shell Size 19, Arrangement 4Q4, RR-RR
Part No. 1811902

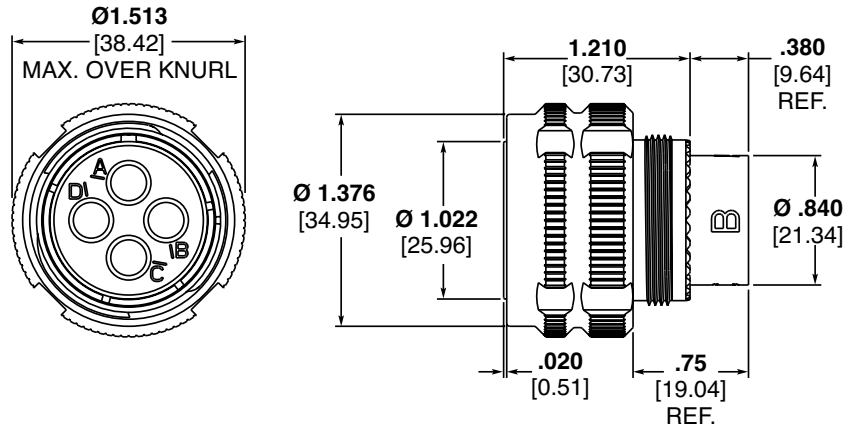

Receptacle, Shell Size 19, Arrangement 4Q4, RR-RR

Part No. 1877732
(w/ PC Tail Contacts)

Part No. 1738974
(connector only)

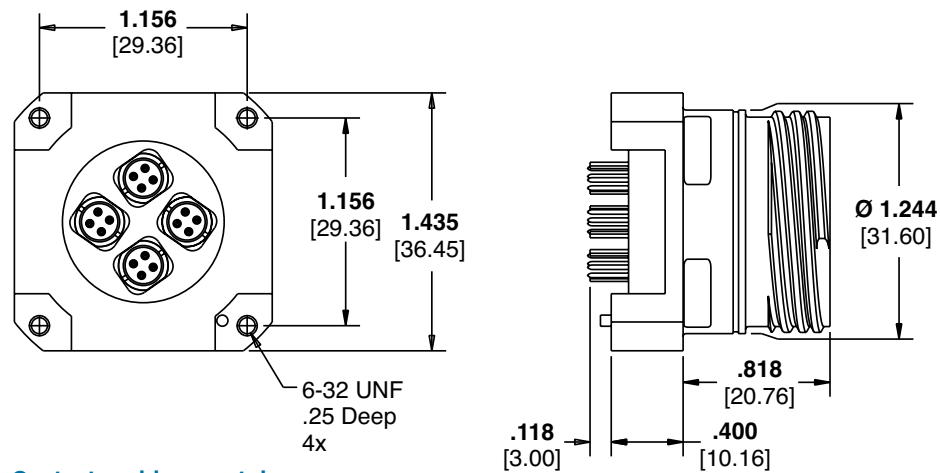

Contacts sold separately
(unless noted)



Custom 38999-Style Series III Quadrax Connectors

Receptacle, Shell Size 19, Arrangement 4Q4, RR-RR
Part No. 1811901

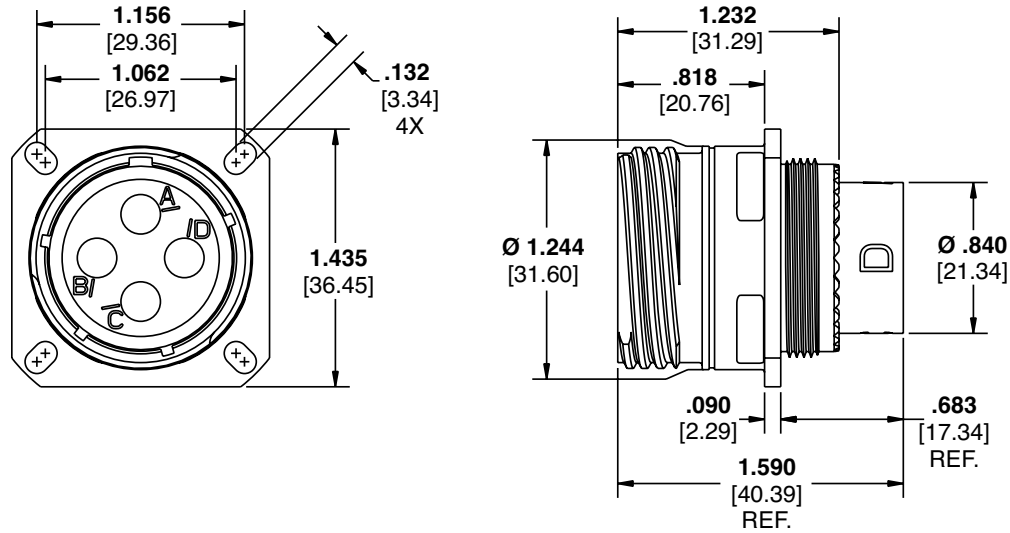

Receptacle, Shell Size 19, Arrangement 4Q4, RR-RR Jam Nut Style
Part No. 2157696

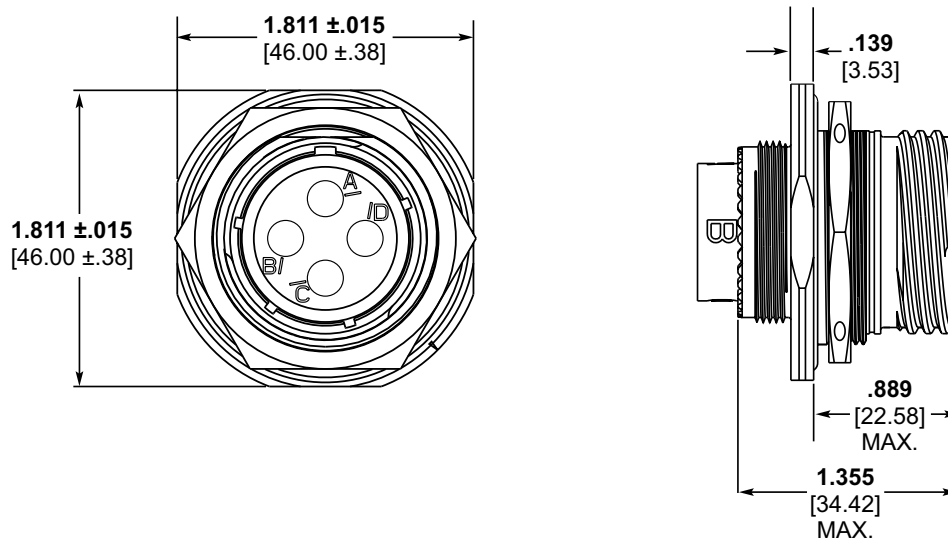



Custom 38999-Style Series III Quadrax Connectors

Receptacle, Shell Size 19 Arrangement 4Q4, With Threaded Mounting Holes
Part No. 2221849

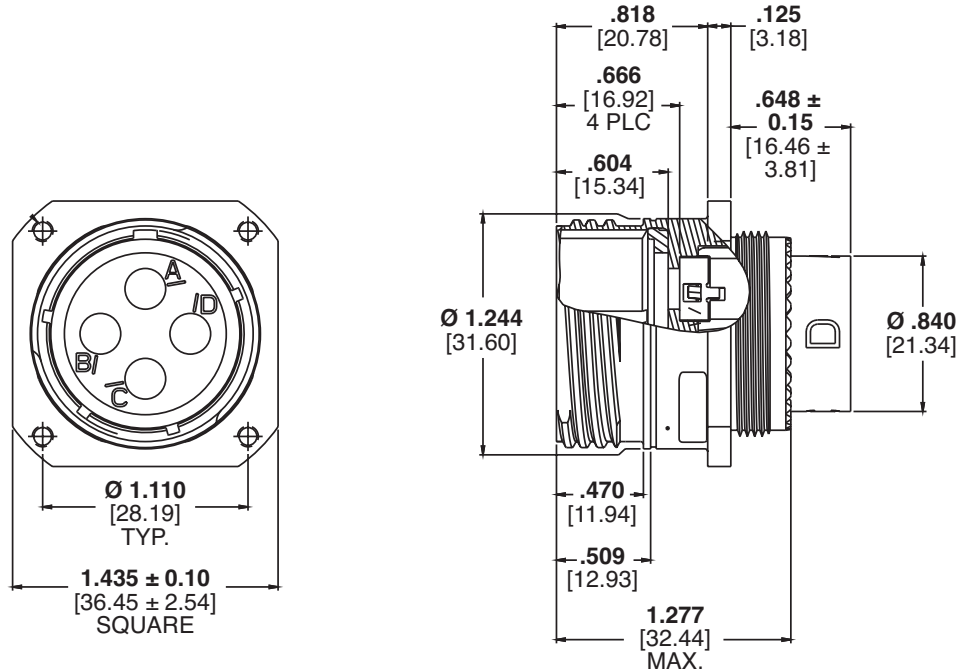

Plug, Shell Size 21, Arrangement 4Q4, FR-FR
Part No. 1954354

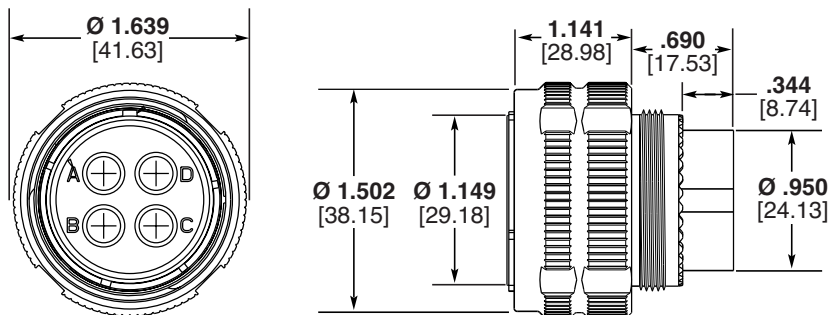



Custom 38999-Style Series III Quadrax Connectors

Receptacle, Shell Size 21, Arrangement 4Q4, FR-FR
Part No. 1954353

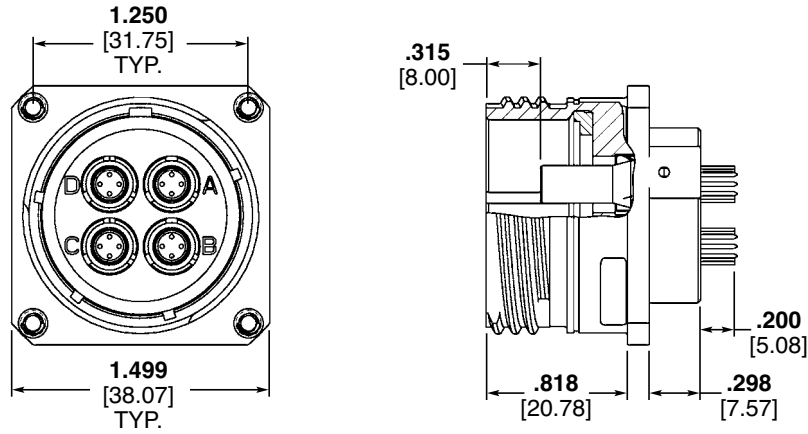

Receptacle, Shell Size 21 38999 Style Arrangement 4Q4, RR-RR Flange Mount
Part No. 2101633

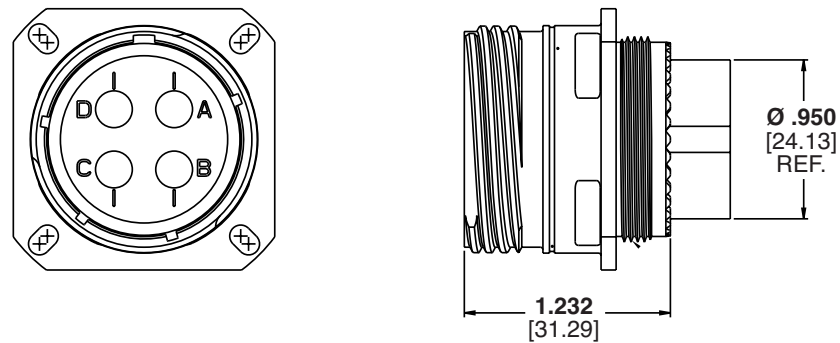

Plug, Shell Size 23, Arrangement 6Q6
Part No. 1877921

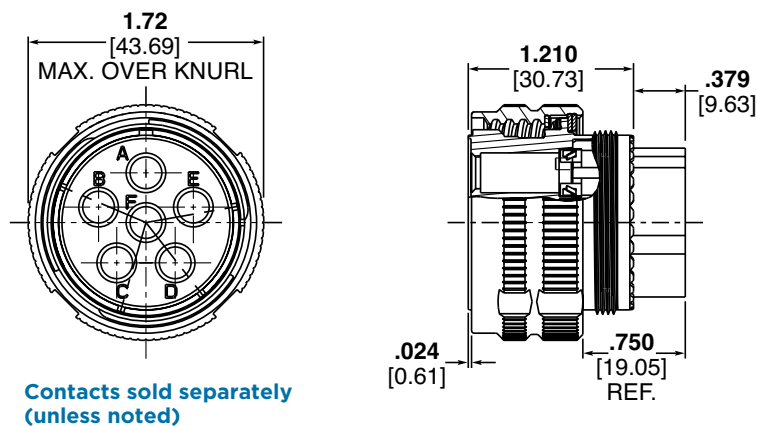

Contacts sold separately
(unless noted)



Custom 38999-Style Series III Quadrax Connectors

Receptacle, Shell Size 23, Arrangement 6Q6,
Part No. 1954577

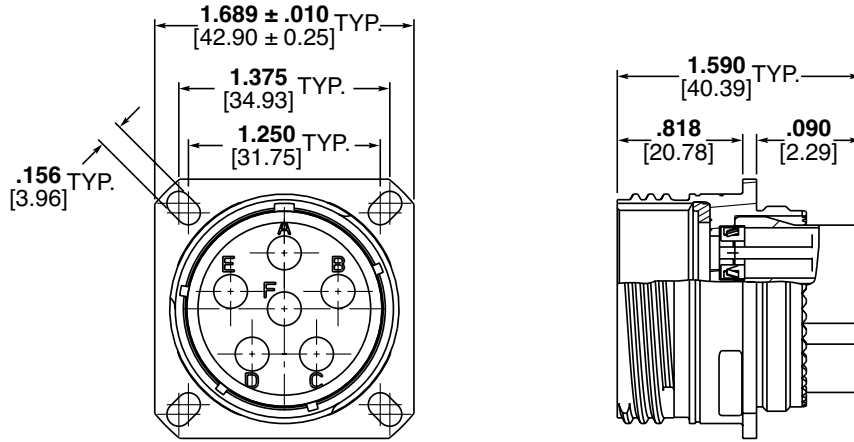

Receptacle, Shell Size 23 38999 Style, Arrangement 6Q6, PCB Mount
Part No. 2221366

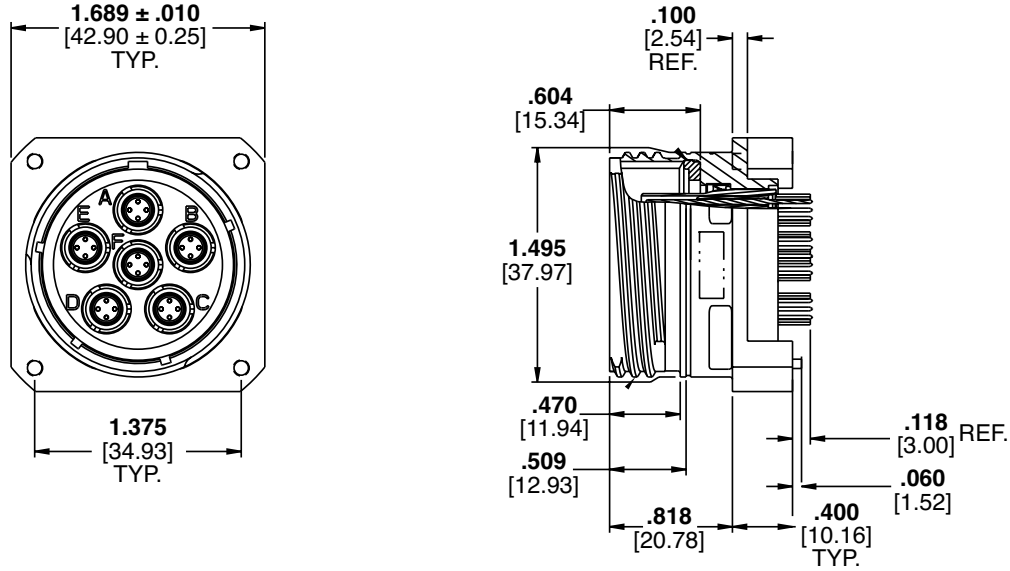



Custom 38999-Style Series III Quadrax Connectors

Receptacle, Shell Size 25 38999 Style, Arrangement 8Q8,RR-RR Jam Nut
Part No. 2157628

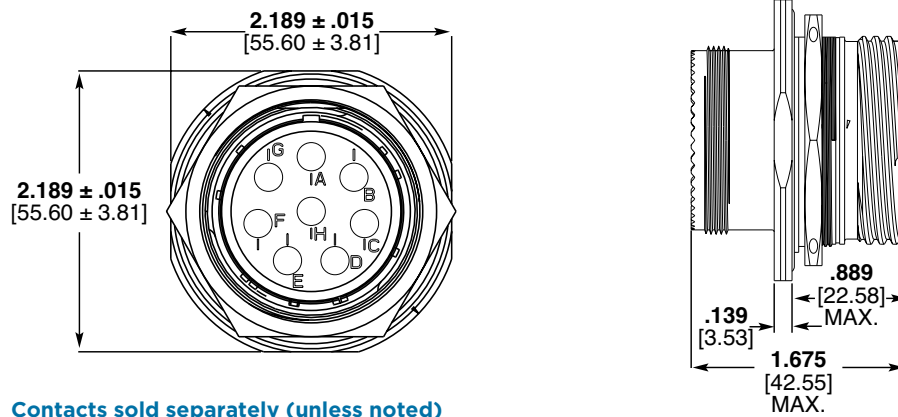

Contacts sold separately (unless noted)

Receptacle, Shell Size 25, Arrangement 8Q8, FR-FR
Part No. 1996625

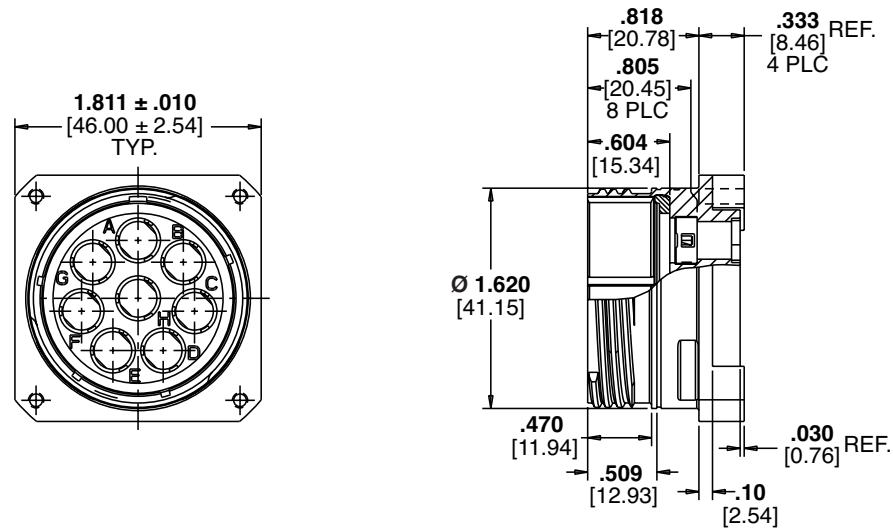



FAST, EASY ASSEMBLY

- One-piece dielectric inserts for easy assembly and to help lower applied cost
- Crimp type, screw machined, 24 AWG contacts
- Quadrax size 8 shells are keyed per ARINC 600 for correct orientation
- Asymmetric standoff leg provides built-in keying for direct attach to PC board

HIGH PERFORMANCE

- TE's Quadrax contacts support 100 Ω GbE and 150 Ω Fibre Channel
- Available silicone seal boots are rated for 50,000 ft. altitude immersion

VERSATILE

- Compatible with a wide range of rectangular and circular connectors
- Cable-applied crimp contacts and PC tail contacts for board-mount soldering

Quadrax Contacts

PC Tail Contacts, Pin

Part No.	Dim A	Notes
1445626-1	5.79 .228	
1445626-2	10.72 .422	
1445626-3	4.60 .181	
1445626-4	7.54 .297	
1445626-5	7.54 .297	Solder Dipped Tails

Millimeters Inches

Crimp Contact Kits

Part No.		Hex Crimp	Wire Seal Boot
Pin	Socket		
1445692-1	1445693-1	5.54 .218	No
1445692-3	1445693-3	5.54 .218	Yes
1445692-4*	1445693-4*	—	Yes
Reference cables: NF24Q100, NF26Q100, 24443/03130X-4(LD), 24443/9P025X-4(LD); Raychem CEC-RWC-18687, Raychem CEC-RWC-18664			
1445692-5	1445693-5	5.54 .218	Yes
1445692-6	1445693-6	5.54 .218	No
Reference cables: F4703-3, F4704-4 (Insulation Diameter Is Larger)			
1877039-1	1877040-1	5.87 .231	No
1877039-2	1877040-2	5.87 .231	Yes
Reference cables: 26473/02006X-4(LD); Raychem CEC-RWC-18684, Raychem CEC-RWC-18680			

Millimeters Inches

* Qualified to Boeing BACC47GA1 (Pin) and BACC47GB1 (Socket)

Crimp Contacts with Heat-Shrink Tubing

Part No.		Hex Crimp
Pin	Socket	
1811269-1	1811010-1	5.54 .218

Millimeters Inches

Direct Attach PCB Contacts

Part No.	Impedance	Tail Length	Dim A
1954576-1	150 Ohms	3.18 .125	6.86 .270
1954576-2	100 Ohms	3.18 .125	6.86 .270
1954576-3	100 Ohms	5.21 .205	6.86 .270

Millimeters Inches

Differential Twinax Contacts

Part No.		Hex Crimp
Pin	Socket	
1811865-1	1811866-1	5.54 .218

Millimeters Inches



Quadrax Contacts

PC Tail Contacts

Part No.	Type	Dim A	Notes
187-0095-01	Pin	7.00 .276	ARINC 600, FAST
187-0095-06		8.10 .319	
187-0095-21		7.00 .276	
187-0095-26		8.10 .319	
187-0178-08	Pin	11.40 .449	FDBA 50, FAST
187-0121-01	Pin	6.35 .250	ARINC 600, FAST, FDBA
187-0121-08		7.45 .293	
187-0121-21		6.35 .250	
187-0121-26		7.45 .293	
187-0136-08	Socket	7.30 .287	ARINC 600, FAST, FDBA
187-0206-08	Pin	12.50 .492	MIL-DTL-38999 Series I, II, and III
187-0281-08	Pin	6.80 .268	983 Series (Arrangement 20-04)

Millimeters Inches

Crimp Contacts

Part No.	Type	Standard	Notes
187-0205-08A*	Socket	EN3155-075F	DMC-M
187-0204-08A*	Pin	EN3155-074M	DMC-M
187-0109-08	Socket	ABS 0974	ARINC 600, FAST, FDBA, 983 Series
187-0108-08	Pin	ABS 0973	ARINC 600, FAST, FDBA, 983 Series
187-0110-08	Pin	GSC-01-31869-00**	—
187-0191-08	Socket	HDDS 105 Specific	ARINC 600, FAST

*"A" suffix indicates sealing sleeve

** Gore cable specific



Quadrax Contacts (continued)

**Size 8 Quadrax
PCB Pin Contact
Front Release/
Front Remove Design
Part No. 1445626-1**
** various tail lengths**

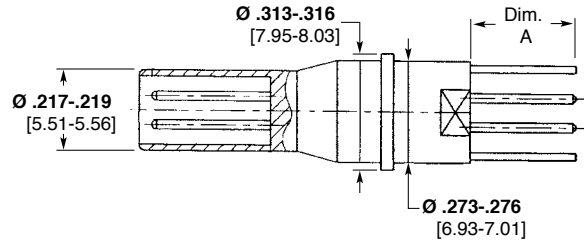
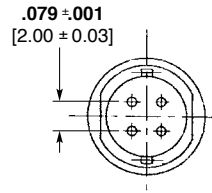

**Blank
Front Release/
Front Remove Design
Part No. 1604940-2**

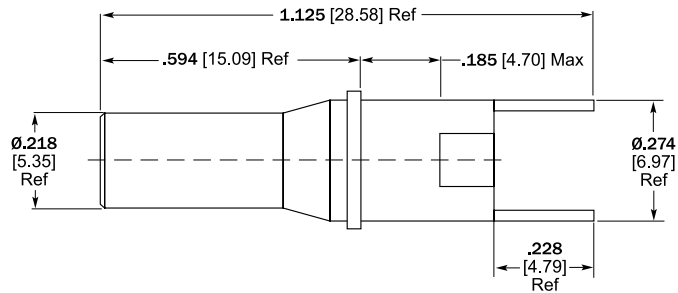
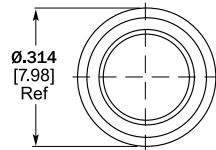

**Size 8 Quadrax
Pin Contact –
Crimp Style
Rear Release/
Rear Remove Design
Part No. 1445692-1*
* -3 with boot**

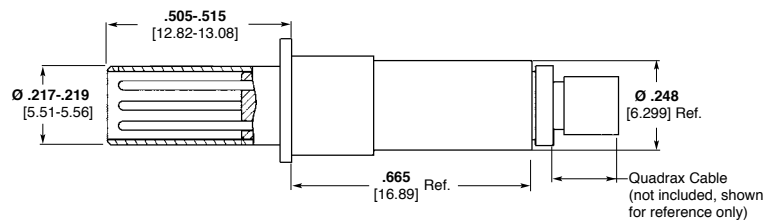
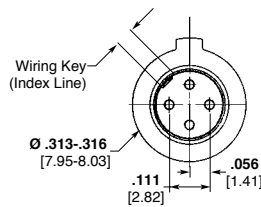

**Size 8 Quadrax
Socket Contact –
Crimp Style
Rear Release/
Rear Remove Design
Part No. 1445693-1*
* -3 with boot**

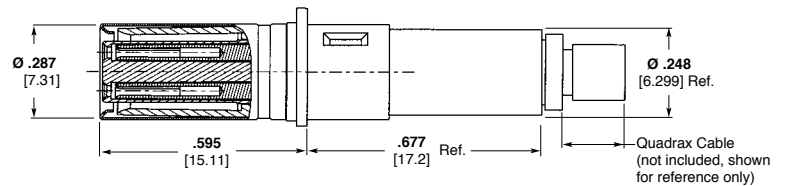
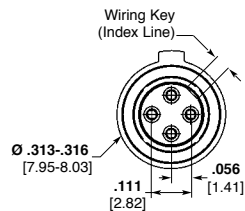



Quadrax Contacts (continued)

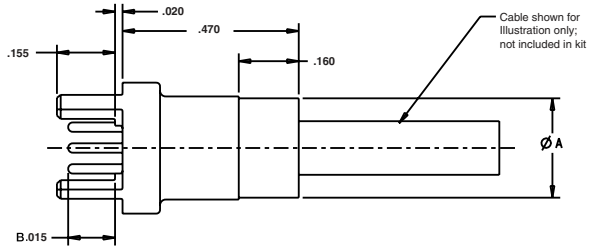
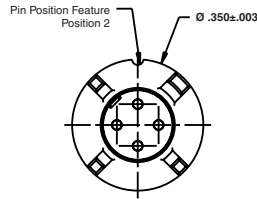

PC Tail Contact - Direct Attach to PCB

- 100 and 150 ohm Systems
- Simple Direct Attach to PCB without connector for component reduction
- Designed from ARINC size 8 Quadrax contacts
- Low cost solution from both assembly and component ends

Part Number 1954576-1, -2: B = .125
Part Number 1954576-3: B = .205

Part No.	Impedance (Ω)	Dim A (Max)	Dim B
1954576-1	150	6.86 [.270]	3.18 [.125]
1954576-2	100	6.35 [.250]	3.18 [.125]
1954576-3	100	6.35 [.250]	5.21 [.205]

Millimeters [Inches]

Size 8 Differential Twinax Contacts

100 Ohm Differential Pair Twinax Contact

- Designed to help meet the requirements of ARINC Specification 810 for 100 ohm size 8 non-concentric twin-axial contacts
- Works in all connectors accepting ARINC 600 style Quadrax contacts

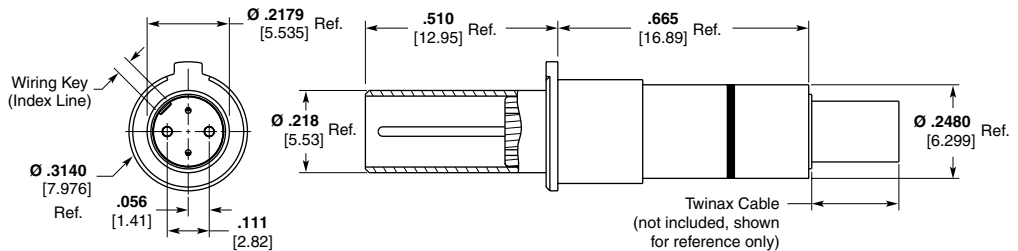

Part No. 1811865-1

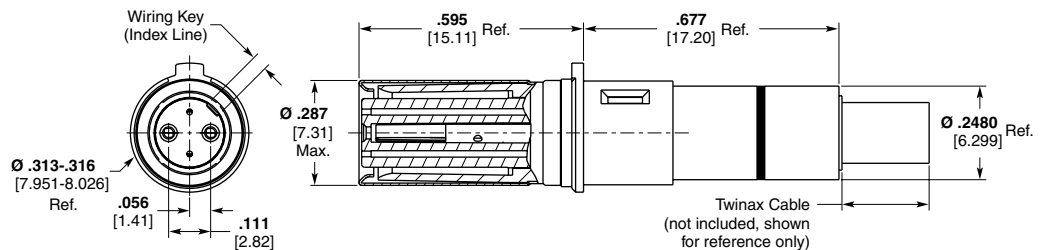

Part No. 1811866-1



Quadrax/Twinax Contact Accessories

Size 8 Quadrax Extraction Tool Part No. 1738894-1

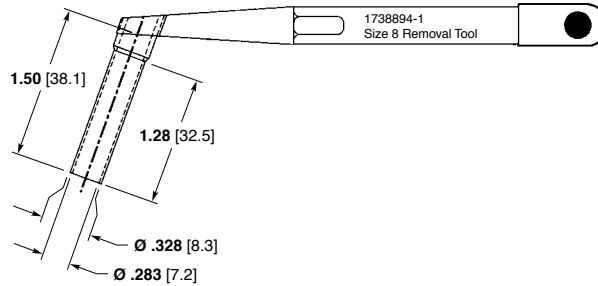

Seal Boots

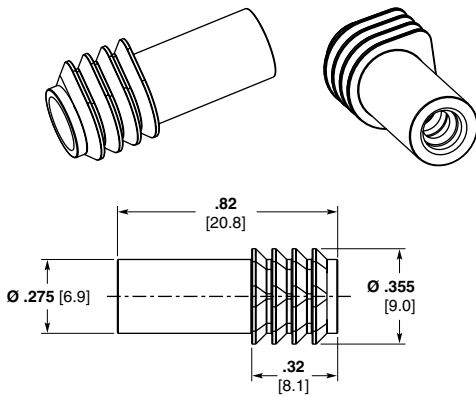

Wire Seal Boot
Part No. 1811481-1
Cable O.D. .145-.175
.218 Hex Crimp

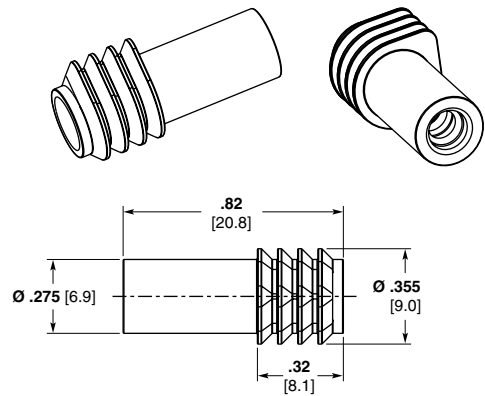

Wire Seal Boot
Part No. 1811943-1
Cable O.D. .170-.200
.231 Hex Crimp

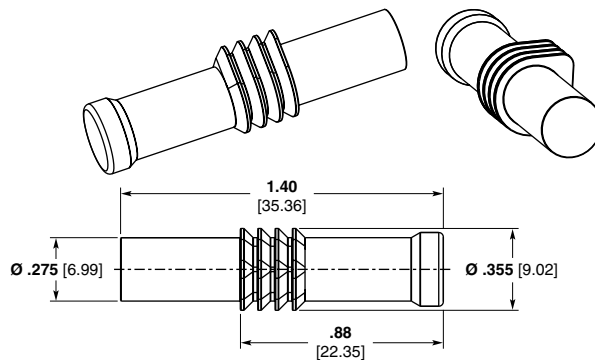

Solid Seal Boot
Part No. 1811633-1



RUGGED

- MIL-DTL-32546 style
- Zero bit error rate
- Proven AS39029 crimp contacts
- Uses 38999-style shell

FAST AND QUIET

- 1 G or 10 GbE data delivery
- Excellent impedance matching and minimal crosstalk
- Size 25 shell supports up to four Ethernet channels

HIGH PERFORMANCE

- Designed for use in rugged environments
- Ideal choice for 10G Ethernet, IEEE 1394, USB 2.0 and other high-speed protocols
- Optimized shielding arrangement for superior signal integrity

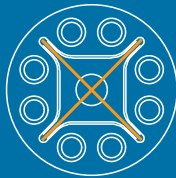

CONVENIENT

- Fast field assembly, termination, and repair
- Available with aluminum or composite shells with a variety of finishes
- Install/repair using standard insertion/removal and crimping tools
- Range of inserts available for Size 25 shell for other connectivity needs

CeeLok FAS-X Connectors



The High-Performance, Rugged Solution for High-Speed Networks

CeeLok FAS-X connectors with AS39029 contacts were designed for rugged environments and help to provide reliable, consistent high-speed performance.

RJ45 connectors in 38999 shells are much larger than the CeeLok FAS-X connector (shell size 19 versus shell size 11). Additionally, the insulation displacement crimp technology may be unsuitable for use in certain harsh environments for which the M39029 crimp contacts used in the CeeLok FAS-X connector were intentionally designed.

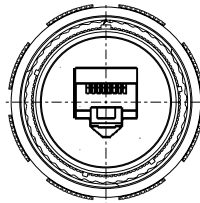

RJ45
One Ethernet Channel
Size 19 Shell
38.35 mm [1.51"] Dia.

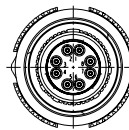

CeeLok FAS-X Connector
One Ethernet Channel
Size 11 Shell
24.89 mm [0.98"] Dia.

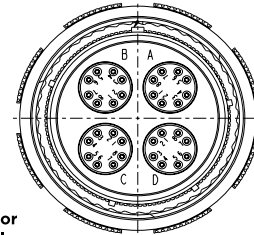

CeeLok FAS-X Connector
Four Ethernet Channels
(Equivalent to four RJ45s)
Size 25 Shell
47.75 mm [1.88"] Dia.



CeeLok FAS-X Connectors

Performance Characteristics

APPLICATIONS

- Military and Aerospace High-Speed Networking
- Gigabit Ethernet and 10G Ethernet Networks
- IEEE 1394b I/O
- Fibre Channel Networks
- Modular 38999

MECHANICAL/ENVIRONMENTAL

- **Temperature Rating:** -65°C to +200°C
- **Mating Cycles (Min.):** 500
- **Plug Diameter:** 0.984" and 1.889" (24.99 mm and 47.98 mm)
- **Sealing IP Rating:** IP67
- **Sealing Altitude Immersion:** 50,000'

ELECTRICAL DATA

- **Dielectric Withstanding Voltage:** 1300 VAC
- **Contact Current Rating (Amps/Contact):** 5

MATERIALS

- **Shells:** Aluminum or composite, nickel plated
- **Contact Finish:** Gold

STANDARDS AND TEST REPORTS

- **TE Qualification Test Reports:** 10065 and 20101203

Excellent Signal Integrity at Gigabit Rates

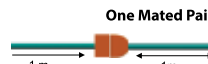
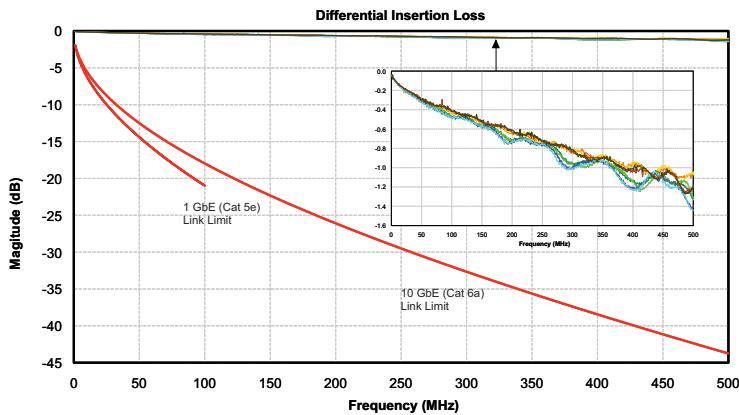

Excellent Impedance Matching

CeeLok FAS-X connectors are designed to maintain a highly matched 100-ohm impedance, with excellent signal integrity.

More High-Frequency Headroom

The design and close impedance matching of the CeeLok FAS-X connector helps give you more performance margin to tolerate noisy environments that are sensitive to harmful interference.

Zero Bit Error Rate (BER) under Rugged Testing

The CeeLok FAS-X connector was tested by TE for bit errors for a high speed signal (1.0625 Gb/s) while simultaneously being subjected to random vibration and temperature cycling between -65°C and +200°C. No bit errors were detected.

For more information, request Test Reports 10065 and 20101203 from TE.

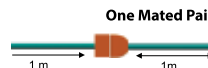
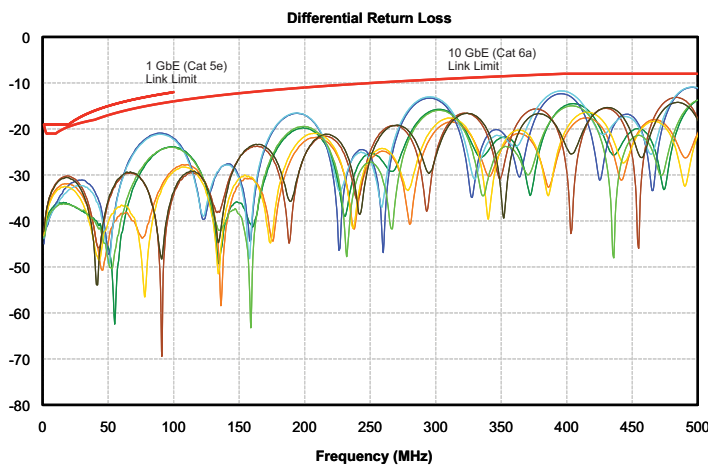



Differential NEXT

D38999 Size 11 Connector MOD Def Standard 23-04 Pinout

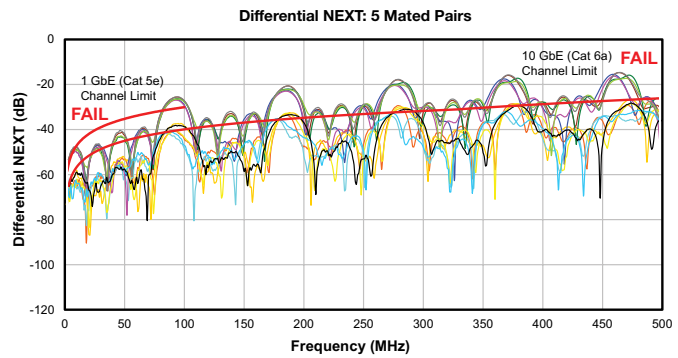
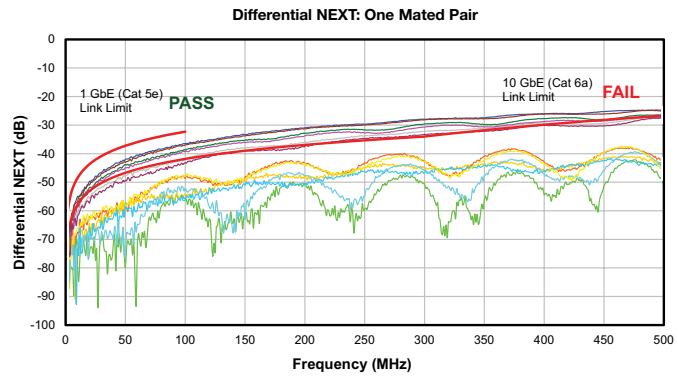
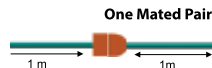
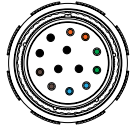

CeeLok FAS-X Connector

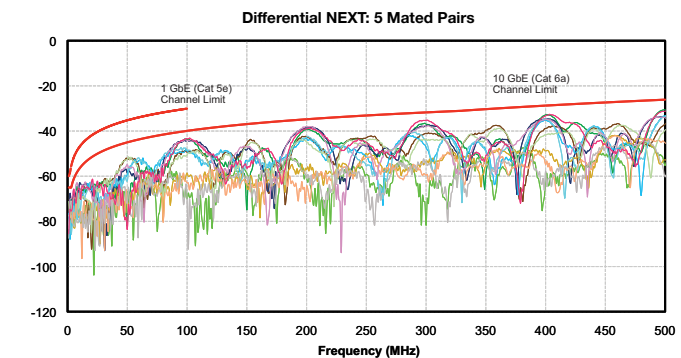
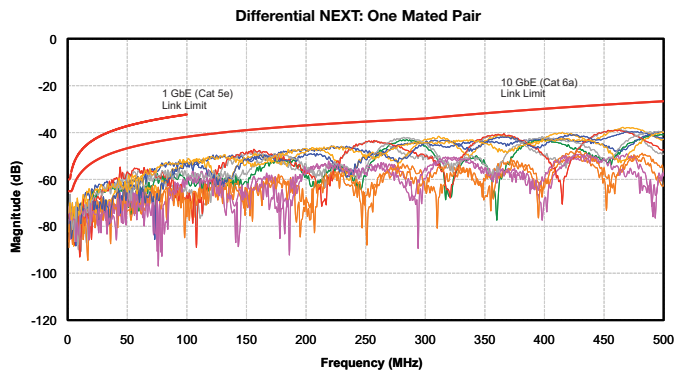
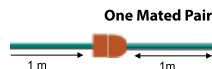



Mil Connectors

ORDERING INFORMATION

Part Numbering System

CFX20 **J** **2532** **P** **Z** **N** **xxx**

GENERAL IDENTIFIER

- CFX20** Square Flange Receptacle (38999)
- CFX21** In-Line Receptacle (38999)
- CFX24** Jam Nut Receptacle (38999)
- CFX26** EMI/RFI Plug (38999)
- CFX30** Square Flange Receptacle (Braid Clamp Backshell)
- CFX34** Jam Nut Receptacle (Braid Clamp Backshell)
- CFX36** EMI/RFI Plug (Braid Clamp Backshell)
- CFX50** Square Flange Receptacle (Push-Pull Lanyard) (81703)
- CFX54** Jam Nut Receptacle (Push-Pull Lanyard) (81703)
- CFX58** Plug (Push-Pull Lanyard) (81703)
- CFX59** Rack-and-Panel Plug (Push-Pull Lanyard) (81703)

CLASS (MATERIAL AND FINISH)

- M** Nickel-Plated Composite
- J** O. D. Cadmium-Plated Composite
- F** Nickel-Plated Aluminum
- W** O. D. Cadmium-Plated Aluminum
- A** Passivated Stainless Steel
- T** PTFE Nickel-Plated Aluminum
- Z** Black Zinc Nickel-Plated Aluminum

SHELL SIZE AND CONTACT ARRANGEMENT

- 1108** Single-Channel, Shell Size 11, 8 Size 22 Contacts
- 2532** Quad-Channel, Shell Size 25, 32 Size 22 Contacts
- 1104** Single-Channel Fibre Channel, Shell Size 11
- 2516** Quad-Channel Fibre Channel, Shell Size 25
- 2500** Quad-Channel, Shell Size 25, No Inserts or Contacts

CONTACT TYPE AND PLATING

- P** Pin, Selective Gold Plating
- S** Socket, Selective Gold Plating
- F** Pin, Full Gold Plating
- G** Socket, Full Gold Plating
- H** Pin, High-Reliability Finish
- J** Socket, High-Reliability Finish
- A** No Pin Contacts Included
- B** No Socket Contacts Included

TERMINATION TYPE

- Z** Crimp
- A** .232" Long Solder Tail (Contact TE for other tail lengths)

KEYING POSITIONS

- N, A, B, C, D, E** (N is normal)

MODIFICATIONS

- 1A** Without Backshell
- 1077** Without Grommet



Single-Channel D38999 Circular, Shell Size 11

Square Flange Receptacle

CFX20*1108***

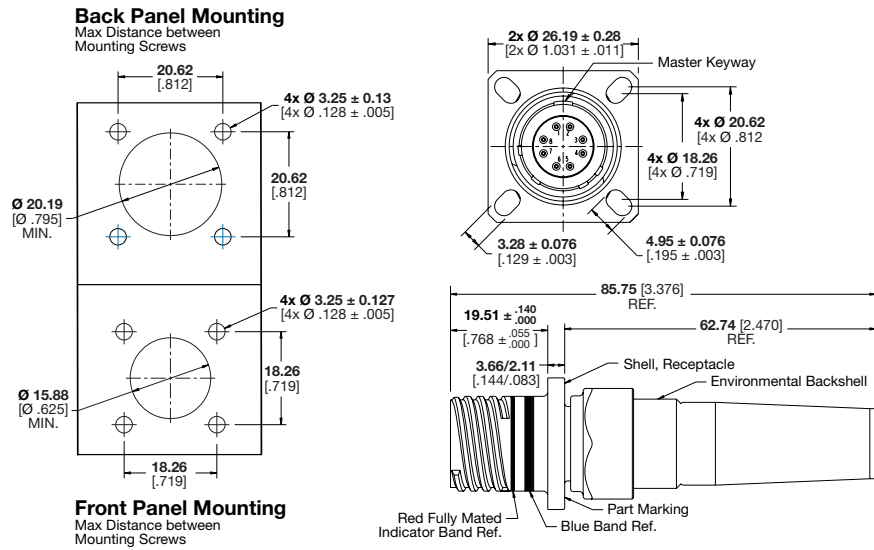

Jam Nut Receptacle

CFX24*1108***

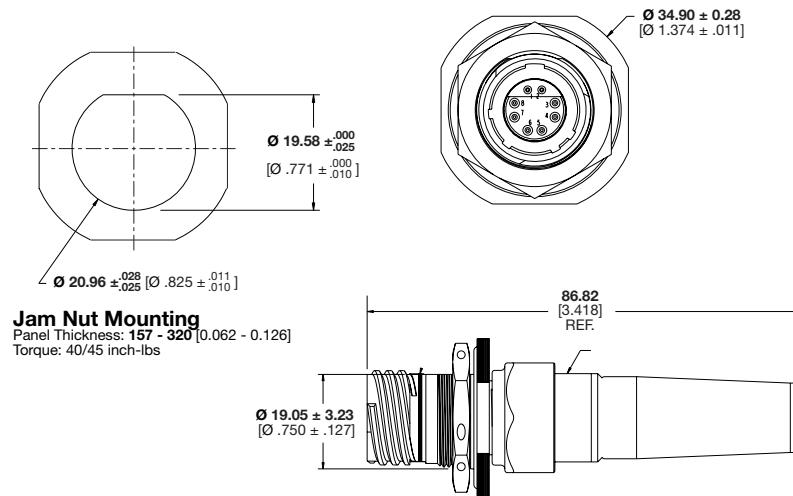

Plug

CFX26*1108***

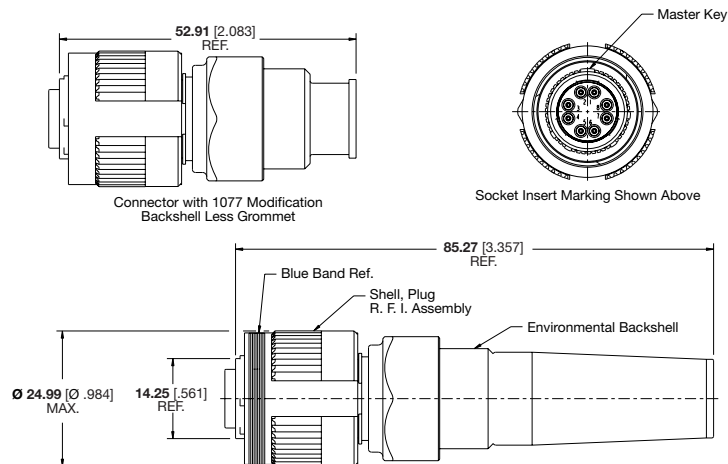



Single-Channel D38999 Circular, Shell Size 11, PCB Mount

Square Flange Receptacle

CFX20*1108***

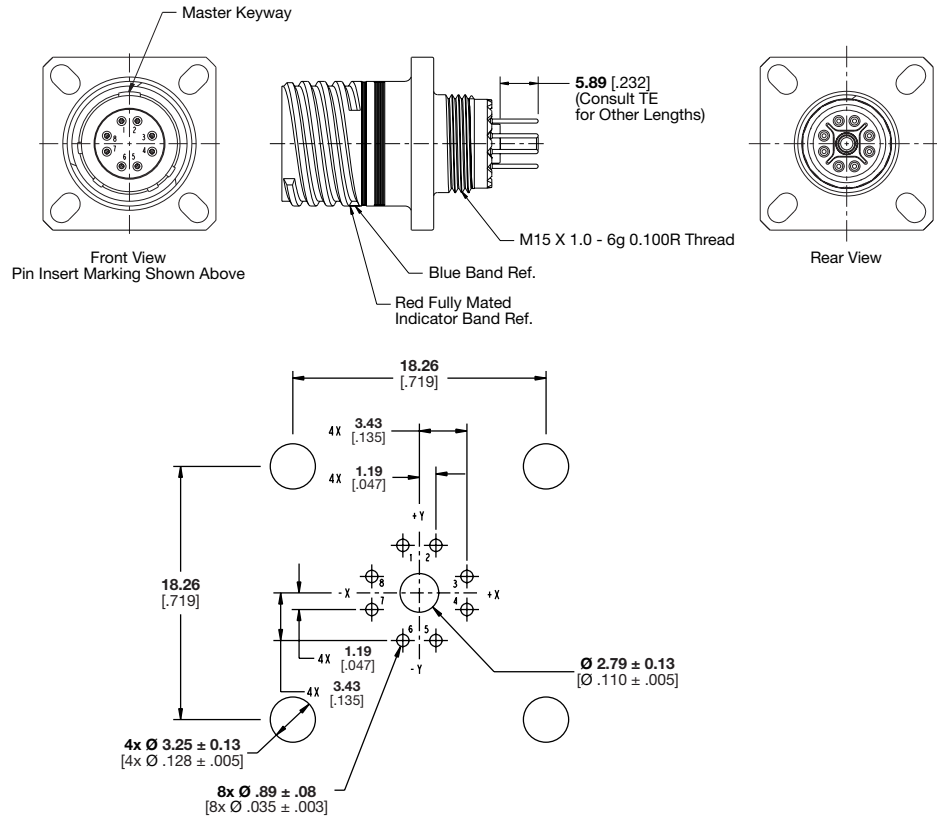

Single-Channel D38999 Circular, Shell Size 11, PCB Mount

Jam Nut Receptacle

CFX24*1108***

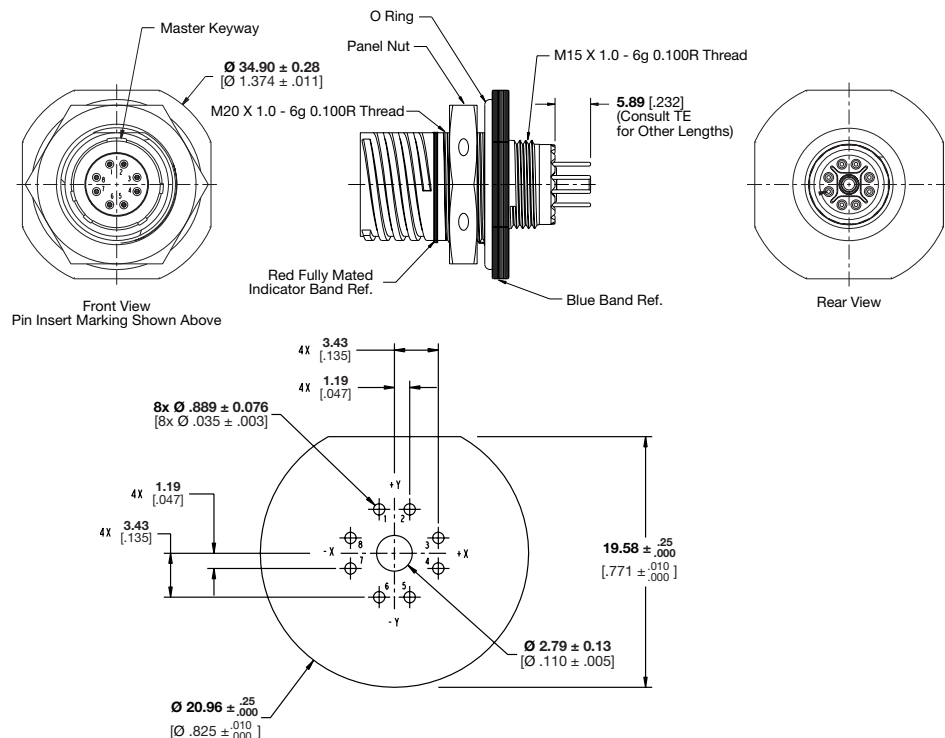



Commercial Single-Channel Circular, Shell Size 11

Square Flange Receptacle with Braid Clamp Backshell

CFX30*1108***

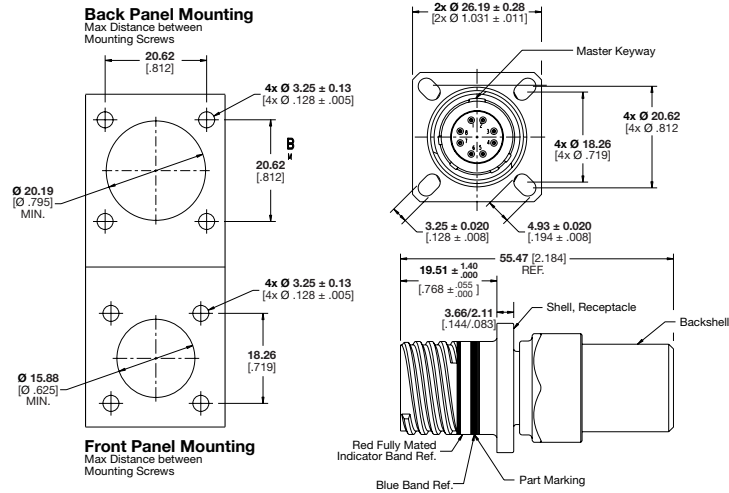

Jam Nut Receptacle with Braid Clamp Backshell

CFX34*1108***

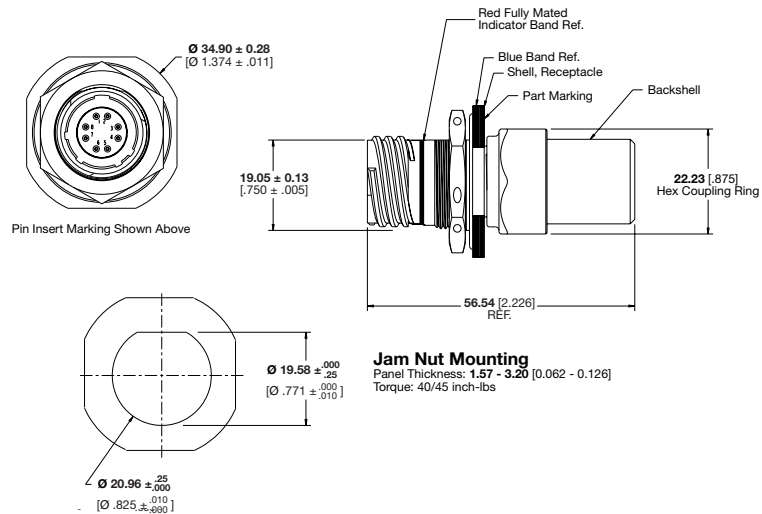

EMI/RFI Plug with Braid Clamp Backshell

CFX36*1108***

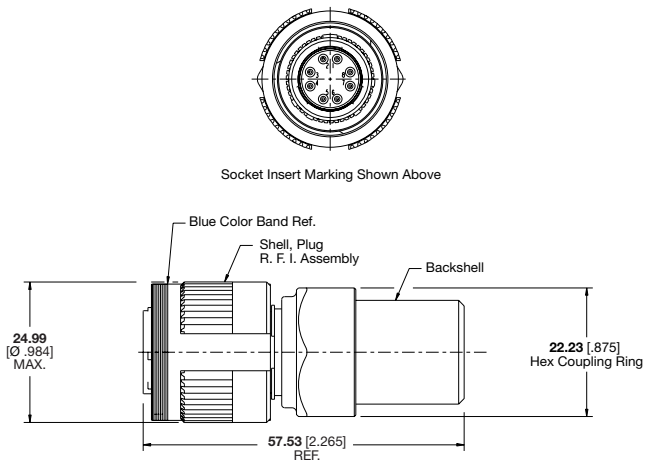



Quad-Channel D38999 Circular, Shell Size 25

Square Flange Receptacle

CFX20*2532***

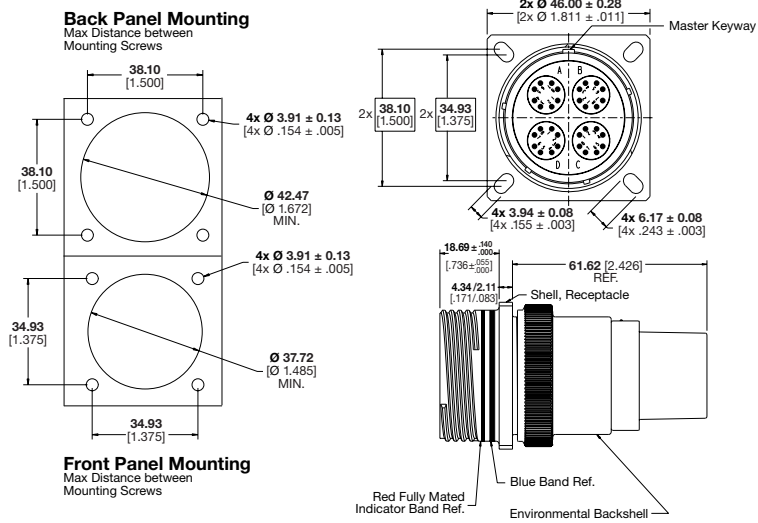

Jam Nut Receptacle

CFX24*2532***

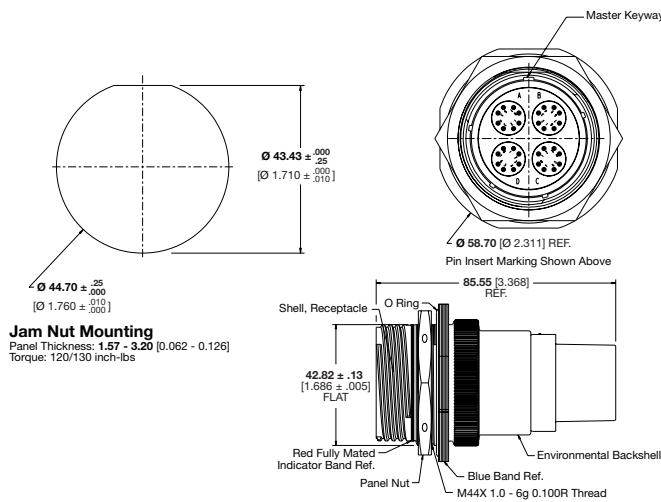

Plug

CFX26*2532***

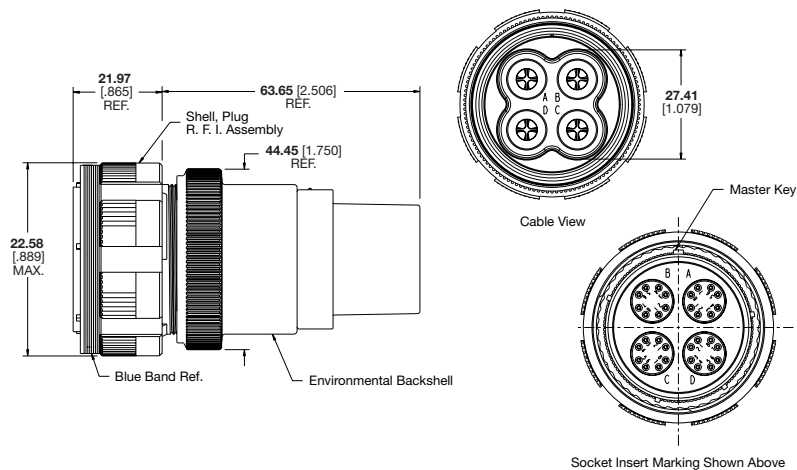



Quad-Channel D38999 Circular, Shell Size 25

Square Flange Receptacle

CFX20*2532***

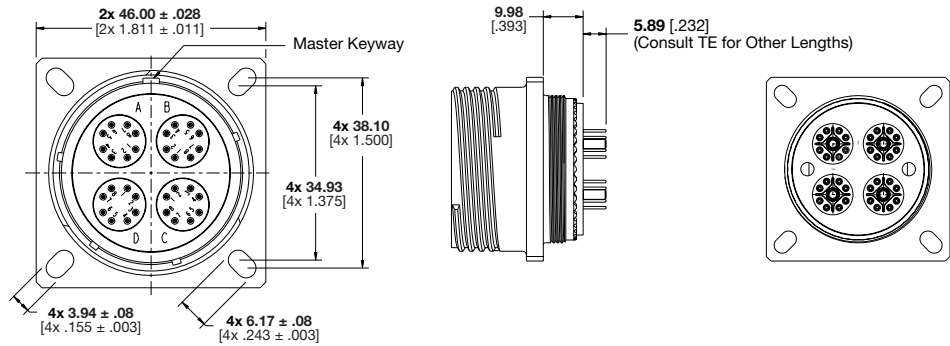

PCB Layout

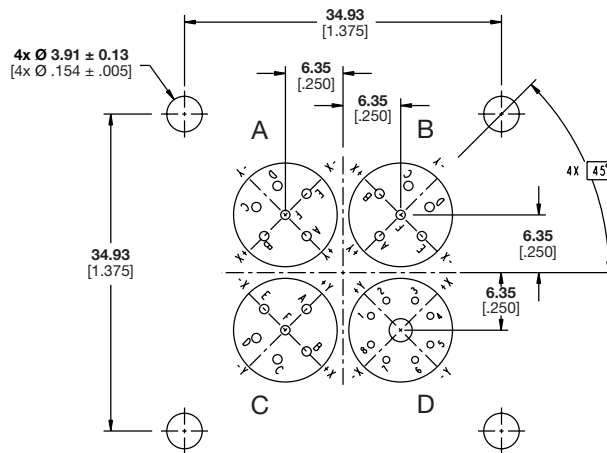



Quad-Channel D38999 Circular, Shell Size 25

Jam Nut Receptacle

CFX24*2532***

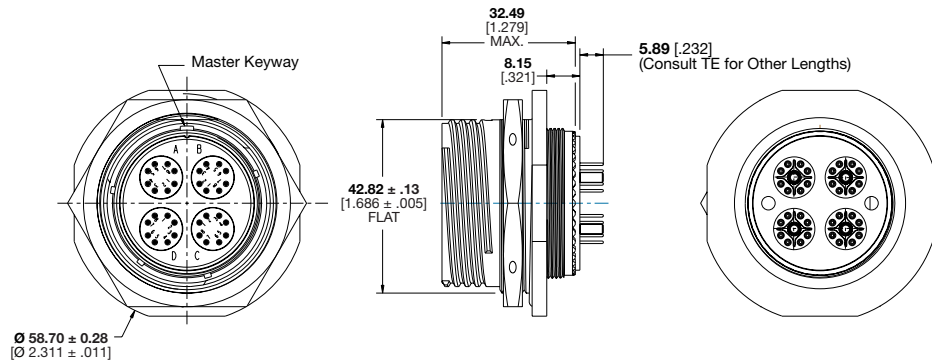

PCB Layout

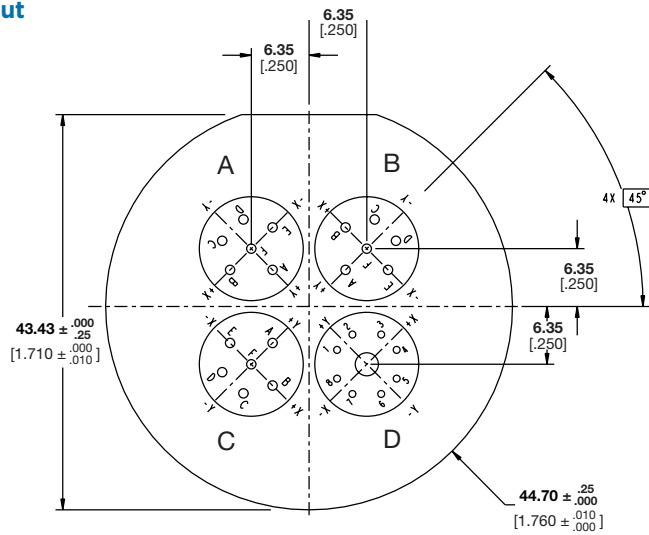



CeeLok FAS-X Connector Modules

CeeLok FAS-X connectors are also available with a variety of modules to accommodate various counts of Size 22, 20, and 16 contacts in a Size 25 shell. Such capabilities help provide a convenient mixture of signal and power through the connectors.

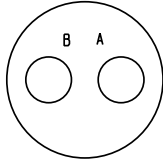

11-02
2 Size 16 Contacts

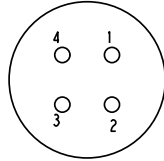

11-H4
4 Size 22 Contacts

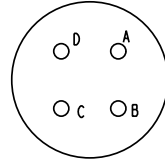

11-04
4 Size 20 Contacts

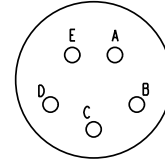

11-05
5 Size 20 Contacts

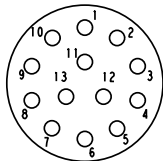

11-35
13 Size 22 Contacts

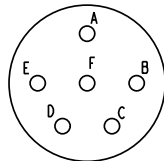

11-98
6 Size 20 Contacts

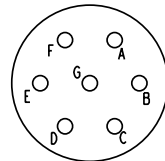

11-99
7 Size 20 Contacts

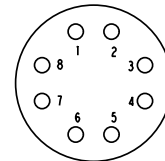

11-H8
8 Size 22 Contacts

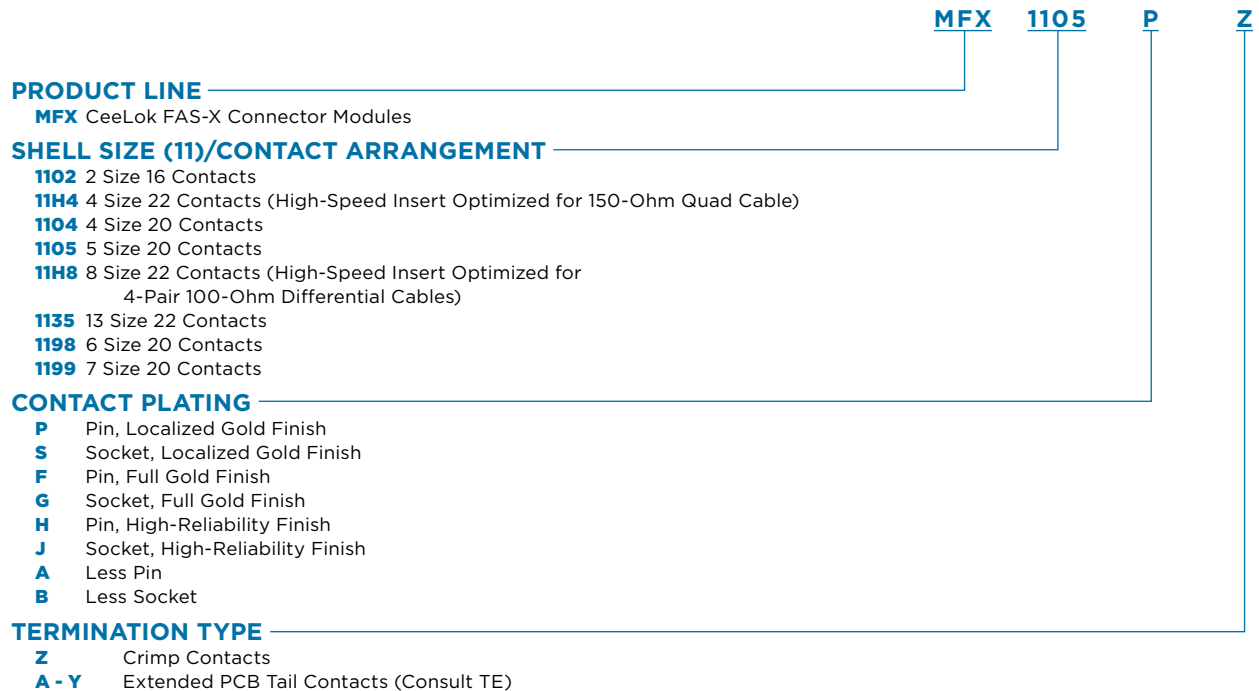



CeeLok FAS-X Connector Modules

Adapters

Tinel-Lock backshell adapters are available to provide reliable braided shield termination using Tinel-Lock rings and accommodate a lipped heat-shrink boot.

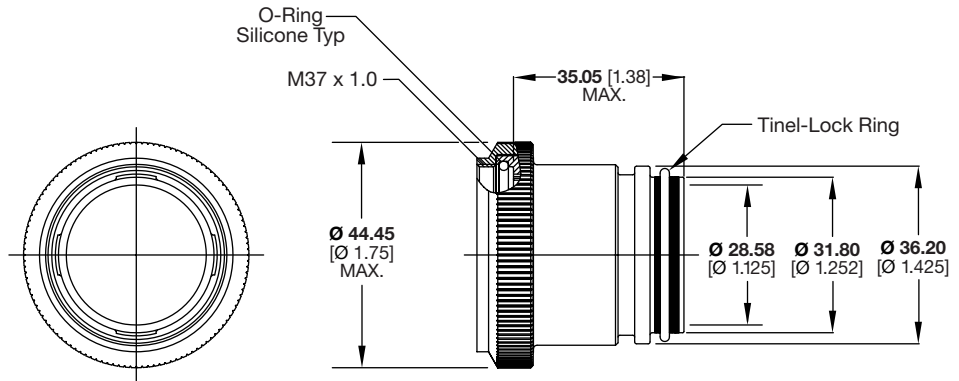

Part No.

TXS201 A X 00-24 BI

TXS201 A X 00-24 AI

Aluminum alloy body with nickel PTFE plating

BI = Tinel-Lock ring for dual-layer 36 AWG or single layer 30 AWG braid shields

AI = Tinel-Lock ring for single layer 26 AWG braid shields

Consult your TE representative for other plating and shield termination options.



CeeLok FAS-X Connector Modules

Size 22D Contacts

28 - 22 AWG wire
 .160 to .190
 recommended
 strip length

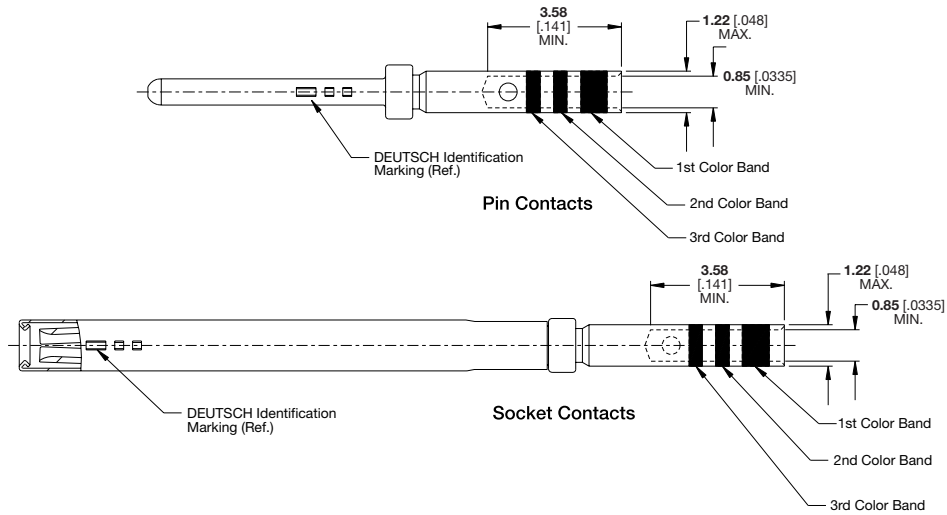

Type	Military Part No.	TE DEUTSCH Part No.*	Color Bands			Crimp Tool	
			1st	2nd	3rd	Basic Tool	Positioner
Pin	M39029/107-620	12331-22	Blue	Red	Black	M22520/2-01	M22520/2-09
	M39029/58-360	38941-22, 38941-22L	Blue	Brown	Yellow	M22520/7-01	M22520/7-07
Socket	M39029/106-614	12333-22	Orange	Blue	Black	M22520/2-01	M22520/2-07
	M39029/56-348	38943-22, 38943-22L	Orange	Yellow	Gray	M22520/7-01	M22520/7-05

*12331-22 and 12333-22 are high-durability contacts rated for 1500 mating cycles.
 38941-22x and 38943-22x are standard durability contacts rated for 500 mating cycles.
 The L suffix indicates localized plating; otherwise plating is standard.



HIGH PERFORMANCE

- Wide temperature range:
-40°C to +120°C
- Shock, vibration, and impact resistant
- Sealed to IP68 standards

RUGGED

- Fully enclosing aluminum, marine bronze and stainless steel shells
- MIL-DTL-38999 series III-style polarized shells
- Positive cordset retention
>100 N axial force

SECURE

- One turn self-locking coupling
- UL 94 V0 low smoke
- RoHS compliant

POLAMCO USB Connector Systems



USB 2.0 and 3.0 38999 Series III-Style Connectors for Harsh Environments

The POLAMCO high-speed USB connector system incorporates a MIL-DTL-38999 Series III-style metal shell with full 360° shielding and mechanical protection.

These USB connector systems have been designed to help meet the requirements of high-speed data connections where reliability through environmental sealing and full mechanical protection are required.

Each USB connector is designed to help handle high levels of shock, vibration and mechanical impact, and is sealed to IP68 standards to help resist fluids and dust for long-term reliable performance.

Three styles using 38999 shells are available:

USB 2.0 Type A

USB 2.0 Type B

USB 3.0 Type A

The USB 2.0 connectors achieve data rates to 480 Mb/s, while USB 3.0 connectors are capable of 5 Gb/s data rates.



Specifications

SHELL MATERIALS

- **Shell:** Aluminum, marine bronze, stainless steel
- **Finishes:**
(Over aluminum with electroless nickel underplating, unless noted):
Electroless nickel
Olive drab cadmium
Olive drab zinc cobalt
Black zinc cobalt
Passivated black zinc nickel
Passivated (Stainless steel shell)
Unplated (Nickel aluminum bronze shell)
- **Seal:** Silicone elastomer, fluorosilicone
- **O-Ring:** Silicone
- **Insulator:** Polyphenylene sulfide, UL 94, black
- **Potting:** Clear silicone encapsulant

USB MATERIALS

- **Contacts:**
USB 2.0: Nickel, selectively gold plated at 30μ
USB 3.0: Nickel, selectively gold plated at 0.76μm
- **Shielding:** Nickel-plated brass
- **Body:** Polyamide, UL 94V-0
- **PCB:** FR4, UL 94V-0 (PCB termination only)

USB Connector Options

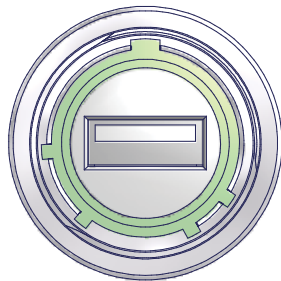

USB-A 2.0

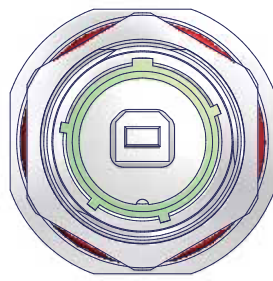

USB-B

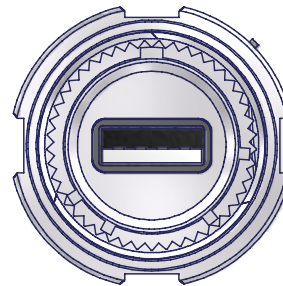

USB 3.0

Connector Orientation Options

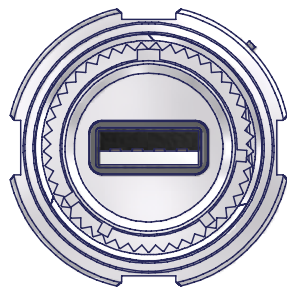

X
(Standard)

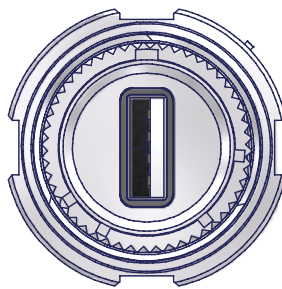

Y

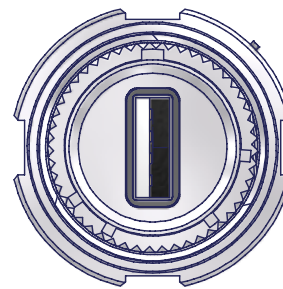

Z

DATA TRANSMISSION

- **USB-A 2.0:** 480 Mb/s
- **USB-B:** 60 Mb/s
- **USB 3.0:** Up to 5 Gb/s

ELECTRICAL

- **Voltage:** 30 VAC
- **Current Rating:** 1 A max. per contact
(1.8 A max. USB 3.0 pins 1 and 4)

ENVIRONMENTAL/MECHANICAL

- **Temperature Ranges:** -40°C to +120°C
- **Fluid Resistance:** IP68 (mated)
- **Cable Retention:** >100 N (22.4 lbs.) axial force
- **Durability:**
USB 2.0: >500 mating cycles
USB 3.0: 5000 mating cycles



POLAMCO USB Connector Systems

POLAMCO USB-A 2.0 38999-Style Connectors Plug

Series

- PC4D0021: Size 15 Memory Plug Assembly (Standard)
- PC4D0048: Size 15 Memory Plug, Isolated
- PC4D0059: Size 15 Memory Plug, Kit
- PC4D0021: Size 15 Memory Plug, Anti-Tamper



Receptacle

Series

- PC4B0054: In-Line Receptacle, Solder (Standard)
- PC4B0089: In-Line Feedthrough Receptacle



Jam Nut, Bulkhead-Mount Feedthrough

Series

- PC4F0027: Sealed Feedthrough (Standard)
- PC4F0049: Sealed Feedthrough (Standard)



Jam Nut Feedthrough Receptacle

Series

- PC4F0009: Size 15 Feedthrough
- PC4F0043: Size 15 Feedthrough, Solder
- PC4F0030: Size 15 Feedthrough with Stand-Offs
- PC4F0059: Size 15 Feedthrough, Sealed
- PC4F0016: Size 15 Feedthrough (Standard)
- PC4F0031: Size 17 Assembly
- PC4F0032: Size 17 Assembly, Solder



Square Flange Bulkhead-Mount Feedthrough

Series

- PC4B0064: Size 15 Feedthrough Assembly





HIGH PERFORMANCE

- Shock, vibration and impact resistant
- Internal grounding fingers for excellent continuity
- Wide temperature range: -40°C to +120°C

CONVENIENT

- No assembly tooling required
- Fast, secure coupling
- RJ45 connectors supplied as kit

RUGGED RELIABILITY

- Rugged 38999 connectors and plugs
- Sealed to IP 68 standards
- Fully grounded from shielded RJ45 plug to 38999 shell

VERSATILE

- Keyway and insert orientations enable 24 total configurations
- Wide range of accessories available
- Fully field repairable

POLAMCO RJ45 Series Connectors



POLAMCO Cat 5 and Cat 6a 38999-Style Connectors for Harsh Environments

The POLAMCO high-speed RJ45 connector system incorporates a MIL-DTL-38999 Series III-style metal shell with full 360-degree shielding and mechanical protection.

These connectors have been designed to help meet the requirements of high-speed data connections where reliability through environmental sealing and full mechanical protection are required.

Tested by TE to 10 Gb/s data rates, the connector shells are available in your choice of aluminum, nickel aluminum bronze, and stainless steel for rugged, reliable performance.

The connectors are fully grounded from the shielded RJ45 plug to the 38999-style connectors. Each is designed to help handle high levels of shock, vibration and mechanical impact, and sealed to IP68 standards to help resist fluids and dust for long-term reliable performance.



Specifications

SHELL MATERIALS

- **Shell:** Aluminum, nickel aluminum bronze, stainless steel
- **Finishes:**
(Over aluminum with electroless nickel underplating, unless noted):
Electroless nickel
Olive drab cadmium
Olive drab zinc cobalt
Black zinc cobalt
Passivated black zinc nickel
Passivated (Stainless steel shell)
Unplated (Nickel aluminum bronze shell)
- **Seal:** Silicone elastomer, fluorosilicone
- **O-Ring:** Silicone elastomer
- **Insulator:** Polyphenylene sulfide, UL 94, black
- **Potting:** Clear silicone encapsulant and polyetherimide resin

RJ-45 MATERIALS

- **Contacts:** Copper, selectively gold plated
- **Shielding:** Nickel-plated brass
- **Body:** Polyamide, UL 94V-0
- **PCB:** FR4, UL 94V-0 (PCB termination only)

ELECTRICAL

- **Voltage:** 50 VDC/35 VAC
- **Current Rating:** 2.1 A at 70°C
- **Category Rating:** Cat 5 or Cat 6a

ENVIRONMENTAL/MECHANICAL

- **Temperature Range:** -40°C to +120°C
- **Fluid Resistance:** Sealed to IP68 for fluid and dust resistance
- **Cable Retention:** >100 N (22.4 lbs.) axial force

RJ-45 Orientation Options

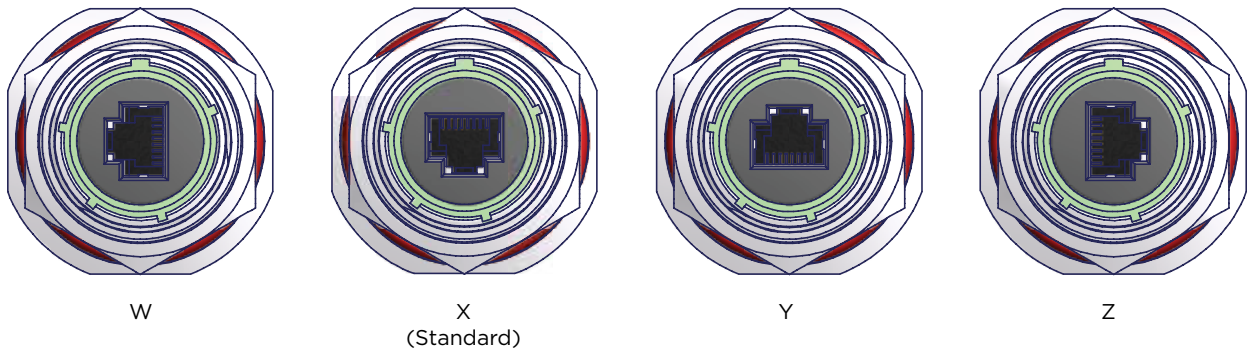



POLAMCO RJ45 38999-Style Connectors

Plug

Series

PC4D0024: Cat 6a

PC4D0042: Cat 6a, Field Installable

PC4D0002: Cat 5



Jam Nut Receptacle

Series

PC4F0020: Cat 6a, Feedthrough (Standard)

PC4F0023: Cat 6a, 90° Feedthrough

PC4F0084: Cat 6a, Sealed Feedthrough

PC4F0034: Cat 6a, Solder

PC4F0025: Cat 6a, PCB Mount

PC4F0002: Cat 5 Feedthrough (Standard)



Square Flange Receptacle

Series

PC4B0029: Cat 6a Feedthrough

PC4B0102: Cat 6a Sealed Feedthrough

PC4B0038: Cat 6a 90° Feedthrough

PC4B0076: Cat 6a PCB Mount

PC4B0002: Cat 5 Feedthrough (Standard)



Bulkhead-Mount Feedthrough

Series

PC4B0103: Cat 6a Square Flange

PC4F0085: Cat 6a, Jam Nut

PC4B0002: Cat 5e Square Flange

PC4F0002: Cat 5 Jam Nut

Cable assemblies are also available in a variety of configurations.
Consult TE.





POLAMCO RJ45 38999-Style Connectors

Typical Part Numbering System

(Not all options are available with every series. Additional options available. Consult TE)

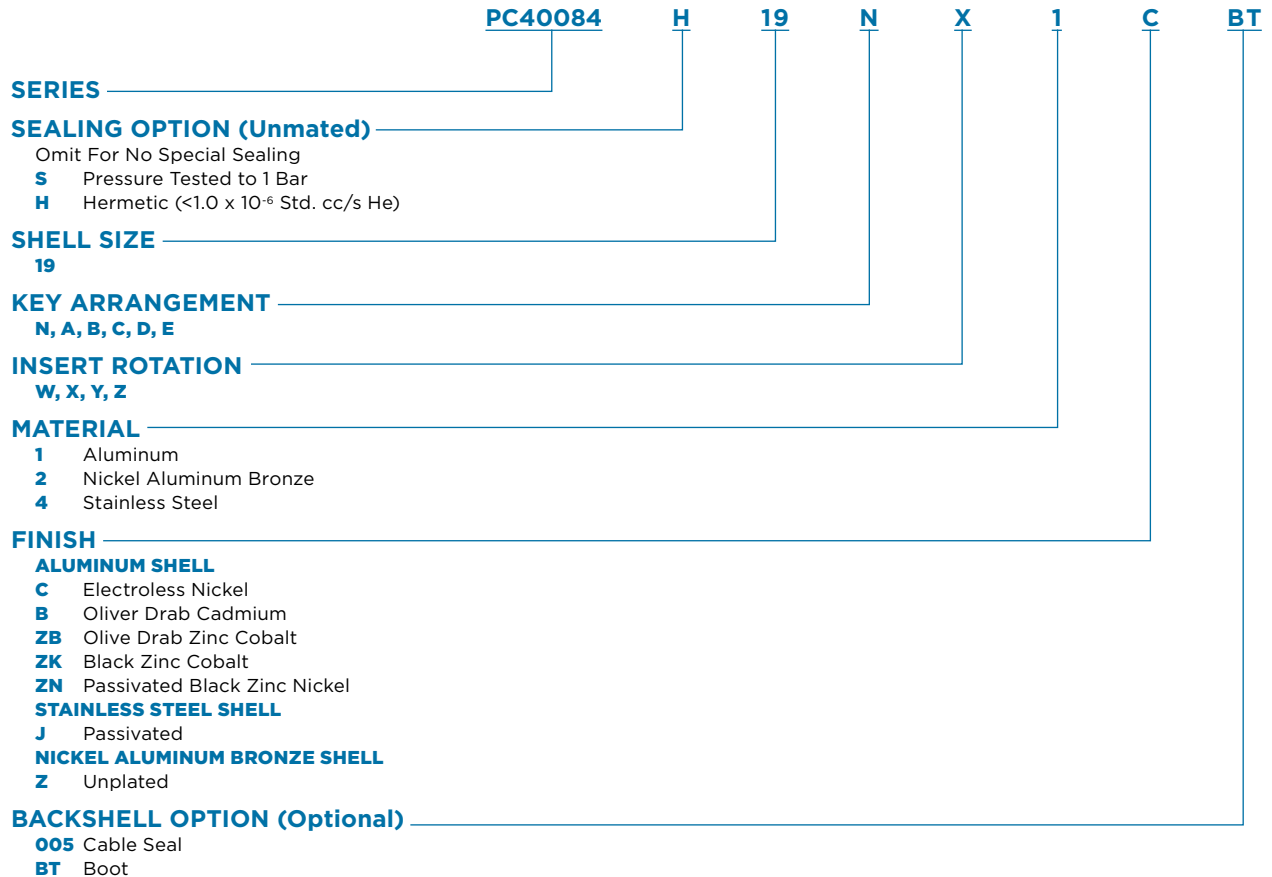



WIDE RANGE

- Physical contact (PC) and expanded beam (EB) interface styles
- Suitable for use across multiple applications and markets, including as military ground, military and commercial aerospace, C5ISR and marine

EASE OF USE

- Rear-removable optical termini
- Removable front inserts for ease of access to optical termini—helping to support simple, effective cleaning and maintenance of termini
- Lens protected EB inserts and termini help protect the fiber core behind the lens and help optimize the performance of the optical link

PRECISION CONNECTIONS

- Dowel pin alignment
- Standard and tight-tolerance keying

RUGGEDNESS

- Environmental sealing
- Anti-vibration coupling mechanisms

Fiber Optic Connectors



38999 Series III Style

As a trusted leader in optical technology with over 40 years of experience in supplying optical solutions for harsh environments, TE offers high-performance 38999-style connector solutions that are also easy to maintain in the field. Our products are designed to operate reliably in harsh and challenging environments, and the company's technical specialists have an in-depth understanding of application requirements.

- **MC801 Connectors:** Industry-standard 1.25-mm ARINC 801 termini
Up to 32 fibers
- **MC3 Mk II Connectors:** DEUTSCH 2.5-mm termini
5, 8, 12 fibers
- **MC4 Connectors:** DEUTSCH 2.5-mm termini
2 fibers in a size 9 shell
- **MC5 Connectors:** DEUTSCH 1.25-mm termini
1, 2, 4, 6, 8, 10, 18, 24, 30 fibers
- **MC6 Connectors:** Single MT ferrule in size 11 shell
2, 4, 8, 12, 24, 48 channels
- **AviMT Connectors:** Four MT ferrules in size 21 shell
Up to 96 fibers
- **Qualified Connectors:** MIL-T- 29504/4 and /5 termini
Fit standard size 16 cavities
- **PRO BEAM Connectors:** Use PRO BEAM EB inserts
1, 2, 4, 8 fibers in size 11 or 15 shell
- **EB16 Termini:** EB termini
Fit standard size 16 cavities



Physical Contact (PC) Connectors

A PC connection uses optical ferrules that are mated within an alignment sleeve and holder to help ensure minimal optical losses and repeatable alignment. The termini can be incorporated into standard circular and rectangular connector to offer multi-channel solutions. PC connections offer

- Low insertion loss
- Low reflection
- High density

While most PC connectors use a ceramic ferrule for a single fiber, the MT ferrule is a multifiber variation typically holding 12 or 24 fibers.

PC solutions offer a higher optical density (Number of channels) and can be used in conjunction with EB interconnects to minimize system losses.

The majority of termini solutions available from TE are spring loaded to help prevent optical discontinuities under shock and vibration.

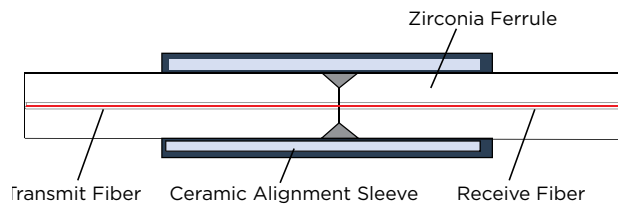

Expanded Beam (EB) Connectors

EB connectors expand and re-focus light at the fiber end faces and allow an air gap in the optical pathway. The EB concept uses optical lenses (typically a 3-mm ball lens for dedicated inserts or 1.25-mm lens for EB16 termini) to expand and collimate the beam emitted from the launch fiber.

The expanded beam remains collimated across the mechanical interface until the receiving lens focuses the beam onto the receiving fiber.

Standard channel counts for EB-specific connectors are 1, 2, 4 and 8. Since these connectors are used in rugged and tactical environments, they are usually terminated on robust ruggedized, metal-tubed, and avionics/flight-grade cable.

The EB16 optical termini employs the same technology from the well-established dedicated inserts into a termini that can be used in 38999 Series III size 16 cavities to allow for flexibility and higher fiber counts.

The absence of physical fiber contact makes EB connectors very useful in demanding environments. They offer:

- Sealed optical interface
- High vibration and shock resistance
- High mating-cycle durability
- Tolerance to dirt and debris
- Easy cleaning

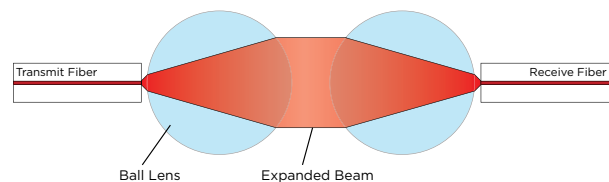

Comparison of PC and EB Connector Technologies

Performance Criteria	PC	EB
Insertion Loss	★★★★	★★
Return Loss (SM)	★★★★	★★
Return Loss (SM)—Unmated	★	★★
Lateral Connector Misalignment	★	★★★★
Connector Angular Tilt	★★★★	★
Mating Durability	★★★	★★★★
Water Exposure	★★★	★★

Performance Criteria	PC	EB
Dust Exposure	★★★★	★★★
Vibration Susceptibility	★★	★★★
Repair	★★	★★
Cleanability	★★	★★★
Wear	★	★★★
Wavelength Range	★★★★	★★



RELIABLE

- Genderless pull-proof contact design
- Precise alignment of optical interface
- Spring-loaded termini maintain optical contact during shock, vibration, and thermal extremes

EASY TO USE

- Removable alignment insert for easy inspection and cleaning
- Field terminable
- Uses standard size 16 insertion/extraction tools

HIGH PERFORMANCE

- Low loss
- PC and APC end face finishes for multimode and single mode applications
- Helps reduce overall system losses

FLEXIBLE

- Eight shell sizes for 2 to 32 fibers
- Range of shell materials and finishes to help meet various application demands

PROVEN PEDIGREE

- Widely used termini in aerospace and military applications
- Meets ARINC 801.3 requirements
- MIL-DTL-38999 Series III-style shells
- Use widely available 38999 backshells and accessories

COMPATIBLE

- Fully intermateable with other qualified ARINC 801/38999 connectors

MC801 Connectors



38999 Series III-Style Fiber Optic Connectors

The MC801 connector combines the high performance of ARINC 801 optical termini with the convenience of a familiar D38999 Series III connector style.

The connector's threaded coupling and the termini's spring-loaded design make an excellent solution for high-vibration applications. The compact 1.25-mm ferrule provides a high-density solution—with up to 32 fibers in a size 25 shell. The 38999-style connector offers scoop-proof mating, a wide selection of materials and finishes, six keying options, and compatibility with standard 38999 backshells and hardware.

Optical alignment is achieved with a thermoplastic insert containing precision zirconia alignment sleeves. Inserts, which are available for use with either the plug or receptacle, are removable to simplify cleaning. Stainless steel dowel pins also aid alignment during mating.



MC801 Connectors

38999 Series III-Style Fiber Optic Connectors

Specifications

MATERIALS

- **Shell:** Aluminum, stainless steel, marine bronze, and composite
- **Finishes:** Nickel, black zinc nickel, passivated, olive drab cadmium
- **Insert and Alignment Sleeve Holder:** Thermoplastic
- **Alignment Dowel Pins:** Stainless steel
- **Alignment Sleeve:** Zirconia
- **Ferrule:** Zirconia
- **Terminus Body and Crimp Sleeve:** Nickel-plated copper
- **Spring:** Stainless steel

OPTICAL PERFORMANCE

- **Insertion Loss:** 0.10 dB multimode
0.20 dB single mode (APC finish)
- **Return Loss:** Up to -65 dB (single mode, APC finish)
- **Insertion loss tested against a reference patchcord:** IEC 61300-3-4 Method B; also described in ARINC 805 Return Loss: IEC 61300-3-6; also described in ARINC 805

ENVIRONMENTAL/MECHANICAL PERFORMANCE

- **Temperature Range:** -65°C to +85°C
- **Durability:** 100 mating cycles
- **Random Vibration:** No discontinuities >1 dB in excess of 1 μ s (TIA/EIA-455-32 Test Condition B)
- **Mechanical Shock:** No discontinuities >1 dB in excess of 1 μ s (100 g, 6 ms half-sine pulse)
- **Altitude Immersion:** 50,000 ft. (15,200 m)

SPECIFICATIONS

- **Product Specification:** D108-32105
- **Qualification Test Reports:** D501-32031 (Multimode)
D501-32105 (Single Mode)



MC801 Connectors

38999 Series III-Style Fiber Optic Connectors

Jam Nut Receptacle Connector

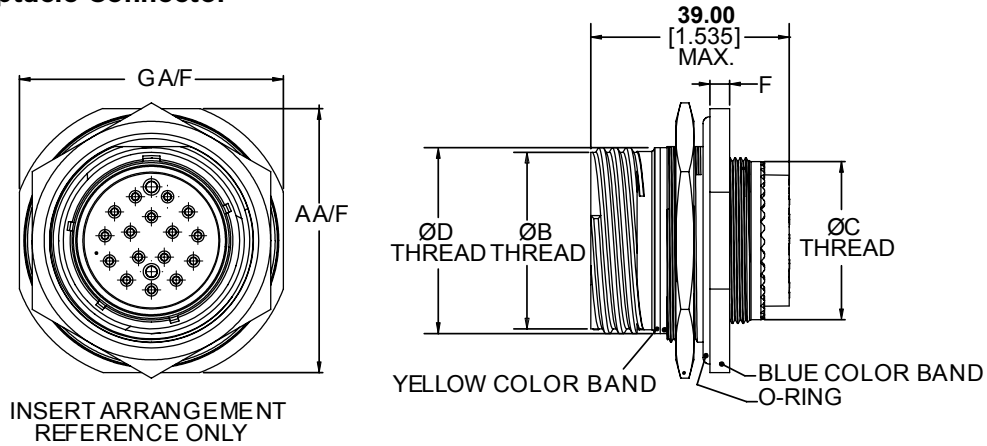

INSERT ARRANGEMENT
REFERENCE ONLY

Insert	ØA	B Thread Stub 60° Mod 1P-3L Class 2A (in)	ØC	ØD	ØE	F	G
11-02	31.80 1.252	0.7500	M15 x 1.0	M20 x 1.0	34.90 1.374		26.75 1.053
13-04	34.90 1.374	0.8750	M18 x 1.0	M25 x 1.0	38.10 1.500	2.84 0.112	31.75 1.250
15-06	38.10 1.500	1.0000	M22 x 1.0	M28 x 1.0	41.30 1.626		35.74 1.407
17-08	41.30 1.626	1.1875	M25 x 1.0	M32 x 1.0	44.50 1.752		36.75 1.447
19-12	46.00 1.811	1.2500	M28 x 1.0	M35 x 1.0	49.20 1.937		40.74 1.604
21-16	49.20 1.937	1.3750	M31 x 1.0	M38 x 1.0	52.40 2.063	3.61 0.143	45.75 1.801
23-24	52.40 2.063	1.5000	M34 x 1.0	M41 x 1.0	55.60 2.189		49.76 1.959
25-32	55.60 2.189	1.6250	M37 x 1.0	M44 x 1.0	58.70 2.311		50.98 2.007

Millimeters Inches

Insert Arrangements

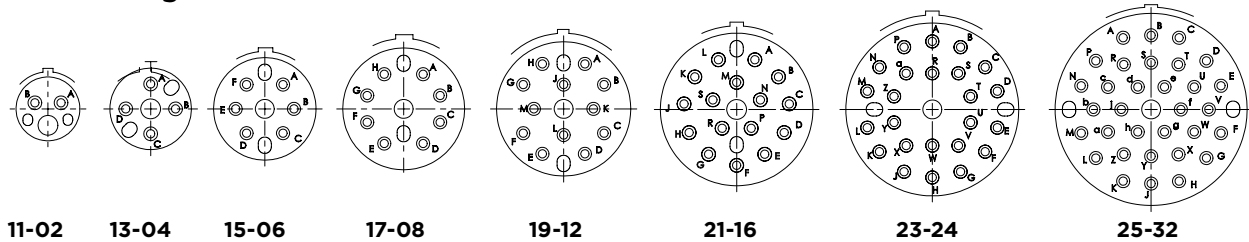



MC801 Connectors

38999 Series III-Style Fiber Optic Connectors

Part Number/Ordering Information

MC801 6 - K - 11-02 S N

PRODUCT FAMILY ————— **MC801**

SHELL STYLE ————— **6**

- 0** Square Flange Receptacle
- 6** Plug
- 7** Jam Nut Receptacle

SHELL MATERIAL AND FINISH ————— **K**

- B** Aluminum Bronze, Unplated
- C** Composite, Cadmium Plated
- D** Composite, Zinc Nickel Plated
- F** Aluminum, Nickel Plated
- K** Stainless Steel, Passivated
- N** Composite, Nickel Plated
- W** Aluminum, Cadmium Plated
- Z** Aluminum, Zinc Nickel Plated

INSERT (SHELL SIZE—NUMBER OF FIBERS) ————— **11-02**

11-02, 13-04, 15-06, 17-08, 19-12, 21-16, 23-24, 25-32

ALIGNMENT STYLE ————— **S**

- P** "Pin"—No Alignment Insert
- S** "Socket"—With Removable Alignment Insert

KEYING ————— **N**

- N** Normal
- A, B, C, D, E**

ARINC 801 Termini

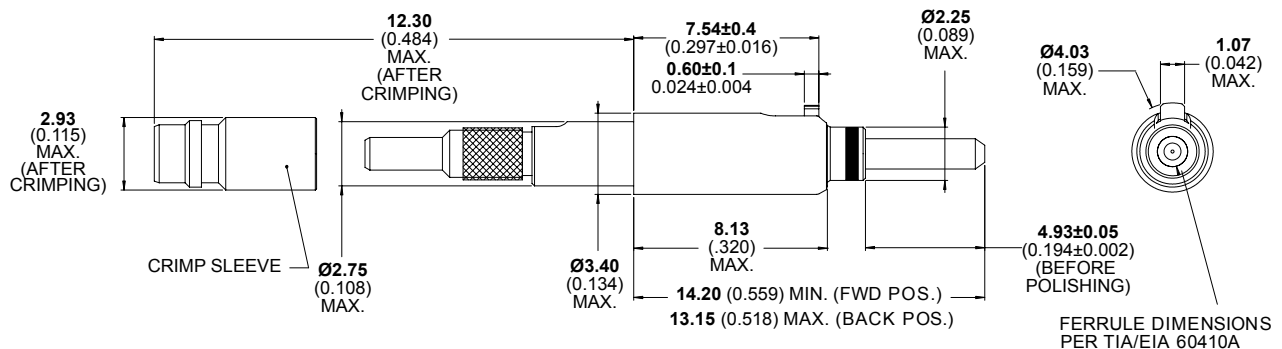

Fiber Type	Part No.			
	Tight Jacket		Loose Jacket	
	1.8 mm Cable	900µm Buffer Cable	1.8 mm Cable	900 µm Buffer Cable
Single Mode	459266-126S-02-1	459266-126S-00-1	459265-126S-02-1	459265-126S-00-1
Single Mode, APC	459266-125A-02-1	459266-125A-00-1	459265-125A-02-1	459265-125A-00-1
Single Mode	459266-126M-02-1	459266-126M-00-1	459265-126M-02-1	459265-126M-00-1

Note: Customer drawings, models, additional product information, and instruction sheets are available at te.com.



EASY TO USE

- Color band indicates full mating
- Insert-to-insert keying assists precision alignment
- Individual rear insertable/removable optical contacts enable easy assembly
- Removable alignment sleeve for easy cleaning
- Simple termination and tooling

RUGGED RELIABILITY

- Spring loaded optical contacts maintain physical contact under severe shock or vibration conditions
- Precision 2.5 mm zirconia ferrules and alignment
- Excellent repeatable optical performance
- MIL-DTL-38999 Series III anti-vibration coupling mechanism and tri-start thread

VERSATILE

- Backshells and adaptors available for most single and multifiber cable
- Alternative shell keyway orientations prevent mismatching
- Dynamic O-ring seal between mating shells for water submersion capability

DEUTSCH MC3 MkII Fiber Optic Connectors



MIL-DTL-38999 Series III Style Connectors

The DEUTSCH MC3 MkII Series ruggedized connectors incorporate individual rear-insertable optical contacts. The removable socket insert helps support easy access to the optical faces to help simplify cleaning and maintenance.

The MC3 MkII Series uses a removable alignment insert for easy cleaning (can be specified in both plug and receptacle shells), and is suitable for use with most single mode and multimode optical fibers with core diameters from 5 to 200 μm . 5, 8, 12 optical channels are accommodated in the MIL-DTL-38999 Series III-style connector shells.

Featuring spring-loaded optical contacts, tri-start threads and anti-vibration couplings, MC3 MkII connectors are a rugged choice for use in many severe environments and tough application conditions.



DEUTSCH MC3 MkII Fiber Optic Connectors

MIL-DTL-38999 Series III Style Connectors

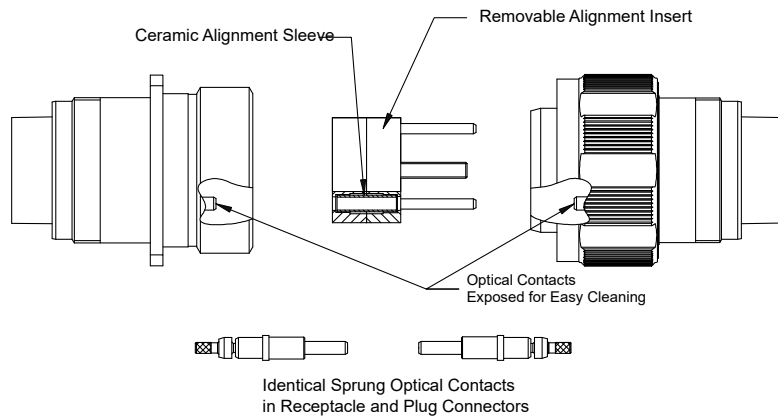

Specifications

FIBER TYPE

- **Channels:** 5, 8 and 12 optical channels
- **Cable Size:** 1.5 mm to 3.0 mm, outer jacket

MATERIALS

- **Shell:** Aluminum, stainless steel, marine bronze
- **Finishes:** Nickel, olive drab cadmium, or black zinc nickel (aluminum shell)
- **Contact Body:** Arcap, Titanium
- **Ferrule:** Zirconia
- **Alignment Sleeve:** Zirconia
- **Alignment Pin:**
- **Seals:** Fluorosilicone or nitrile

OPTICAL PERFORMANCE

- **Insertion Loss:** 0.25 dB typical*
- **Return Loss:** 40 dB typical*
- **Repeatability:** 0.1 dB with 50/125- μ m fiber

*Fiber and polishing process dependent.

ENVIRONMENTAL

- **Temperature Range:** -65°C to +155°C
- **Fluid Resistance:** Fluid immersion per EIA 364.10, including resistance to
 - MIL-PRF-5606: Hydraulic fluid
 - MIL-DTL-83133: JP-8 aviation fuel
 - MIL-PRF-7808: Lubricating oil
 - MIL-PRF-23699: Lubricating oil
 - MIL-A-8243: Deicing/defrosting fluid
 - MIL-C-25769: Aircraft cleaning compound
 - MIL-PRF-87937: Aircraft cleaning compound
 - MIL-G-3056: Gasoline
- **Salt Spray:** 48 hours (Nickel finish)
500 hours (Cadmium finish)
- **Thermal Cycling:** -65° to 150°C



DEUTSCH MC3 MkII Fiber Optic Connectors

MIL-DTL-38999 Series III Style Connectors

MECHANICAL

- **Sine Vibration:** 5 to 3000 Hz, 30 g
- **Bump:** 4000 bumps, 40 g
- **Random Vibration:** Up to 41.7 g for 16 hr. at 175° C
Up to 50 g for 16 hr. at ambient temperature
- **Shock:** 300 g, 3 ms in the 3 axes
- **Durability:** 500 mating cycles
- **Thermal Shock:** 10 cycles, 4°C max. to 90°C min.

Square Flange Receptacle

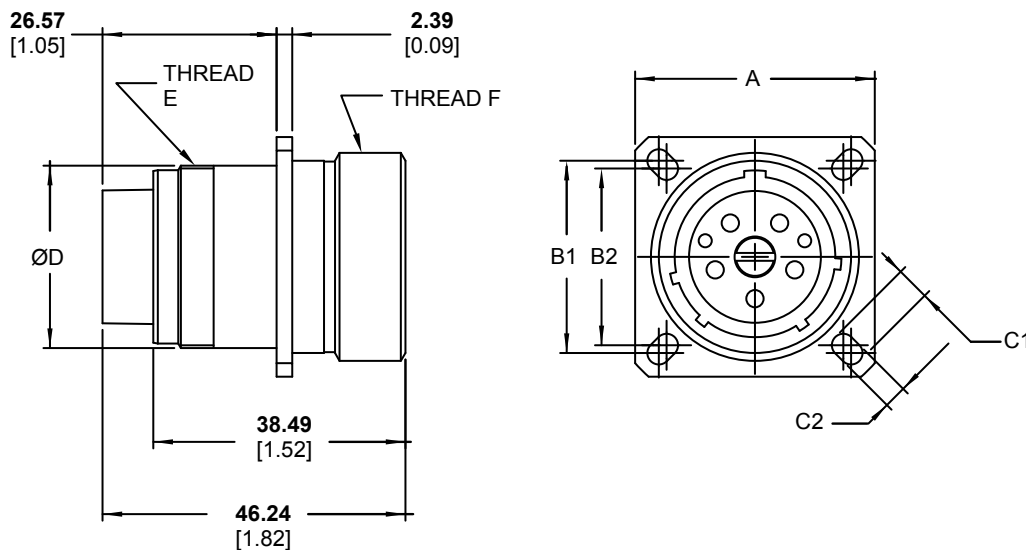

Size/ Arrangement	A	B1	B2	C1	C2	D	Thread E	Thread F
19-5	36.58 1.440	29.35 1.156	26.98 1.062	5.00 0.197	3.50 0.138	27.84 1.096	M28 x 1.0	31.75 1.250
23-8	42.98 1.692	34.92 1.375	31.75 1.250	6.23 0.245	4.00 0.157	33.84 1.332	M34 x 1.0	38.11 1.500
25-12	46.02 1.812	38.11 1.500	34.92 1.375	6.23 0.245	4.00 0.157	36.84 1.450	M37 x 1.0	41.28 1.625

Millimeters Inches

Plug

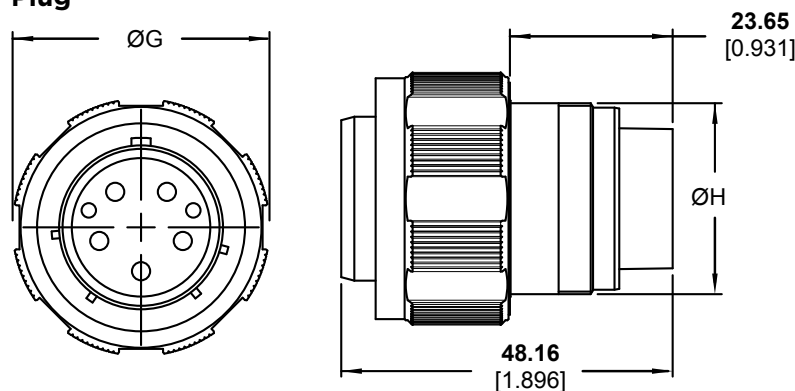

Size/ Arrangement	ØG
19-5	37.92 1.493
23-8	44.12 1.737
25-12	47.35 1.864

Millimeters Inches



DEUTSCH MC3 MkII Fiber Optic Connectors

MIL-DTL-38999 Series III Style Connectors

Dummy Receptacle

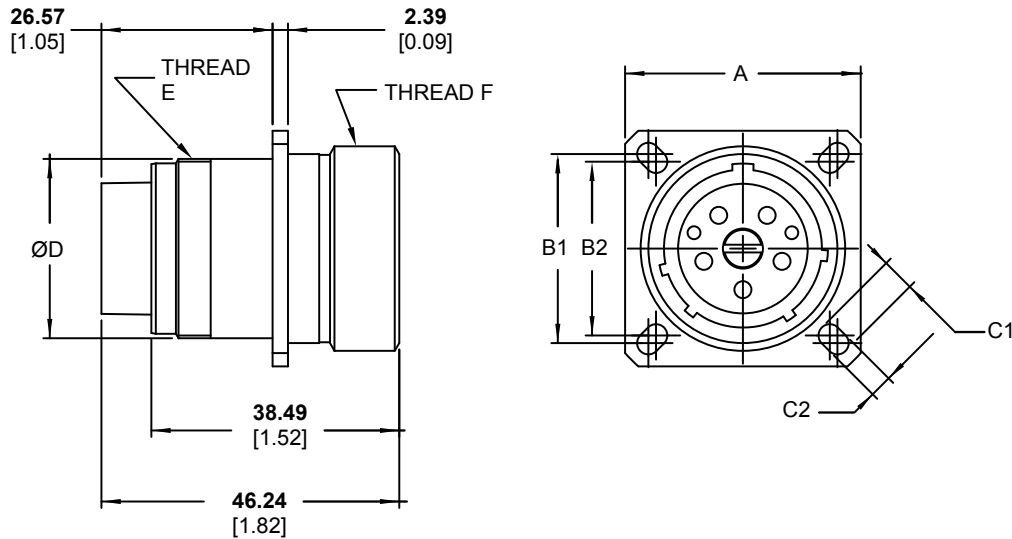

Size/ Arrangement	A	B1	B2	C1	C2
19-5	36.58 1.440	29.35 1.156	26.98 1.062	5.00 0.197	3.50 0.138
23-8	42.98 1.692	34.92 1.375	31.75 1.250	6.23 0.245	4.00 0.157
25-12	46.02 1.812	38.11 1.500	34.92 1.375	6.23 0.245	4.00 0.157

Millimeters Inches

Procaps

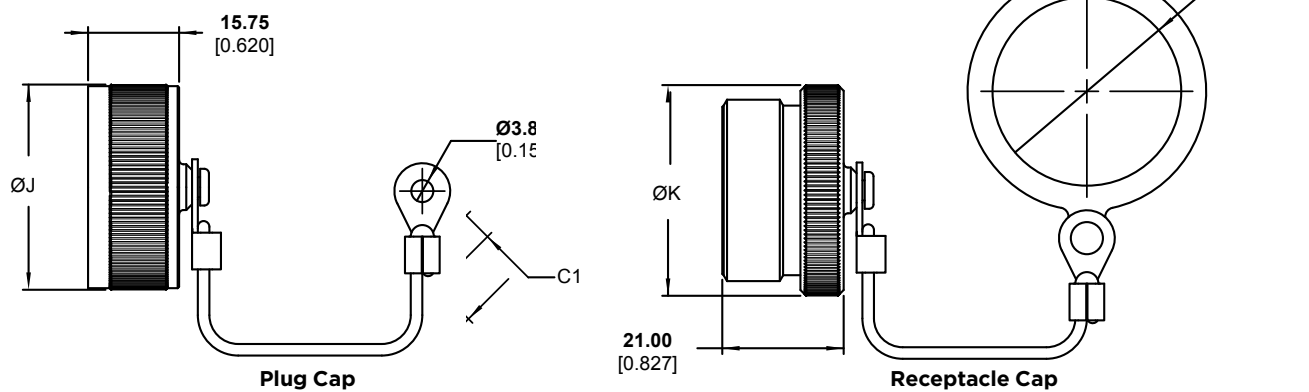

Size/ Arrangement	ØH	ØJ	ØK	ØL
19-5	27.7 1.091	35.4 1.394	36.92 1.454	29.46 1.160
23-8	33.7 1.327	41.75 1.664	43.12 1.698	35.81 1.410
25-12	36.7 1.445	44.93 1.769	46.35 1.825	38.99 1.535

Millimeters Inches



DEUTSCH MC3 MkII Fiber Optic Connectors

MIL-DTL-38999 Series III Style Connectors

Ordering Information

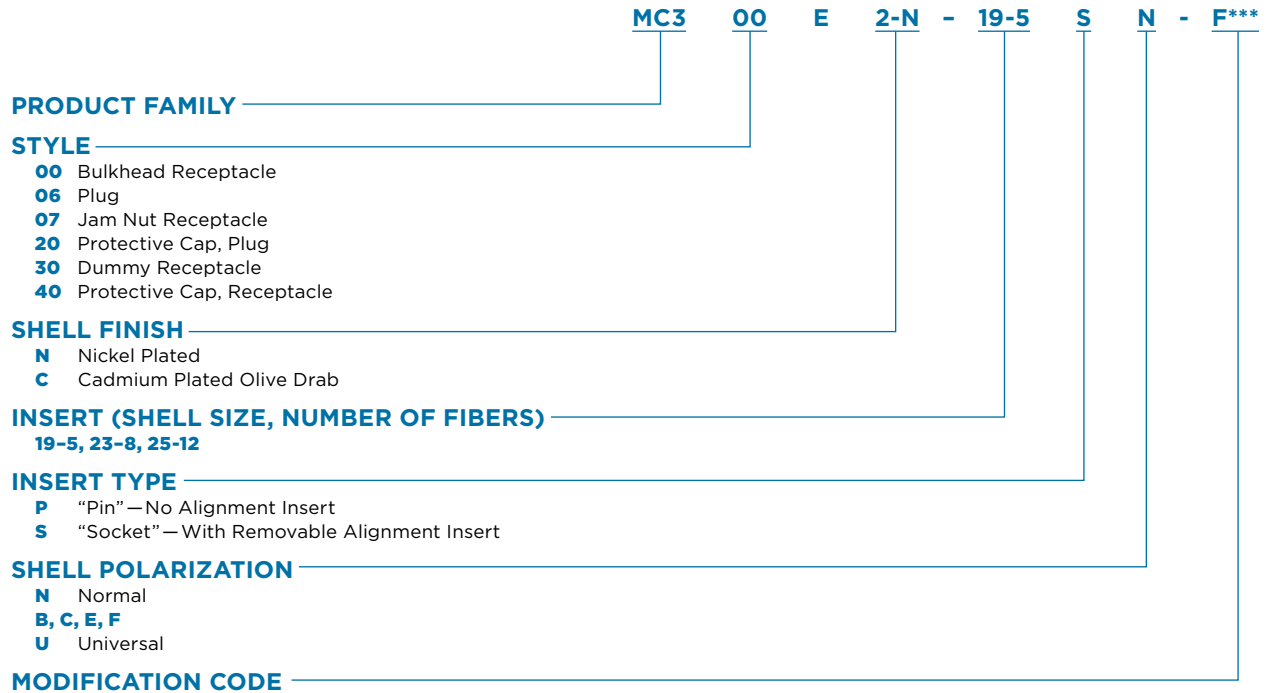



DEUTSCH MC3 MkII Fiber Optic Connectors

MIL-DTL-38999 Series III Style Connectors

Optical Termini (ordered separately)

Optical termini are supplied with a profile-formed optical end face and are available for single-mode or multimode fibers. Contacts are available in either sprung or rigid versions, depending upon application (rigid contacts should be used in bulkhead receptacles only).



Spring-Loaded Type
455500

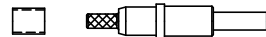

Rigid Type
455494

(Optional for bulkhead receptacles only)

Ordering Information

455500 - 128 - 1-01

TYPE

- 455500** Spring-Loaded Termini
- 455595** Rigid Termini (Bulkhead Receptacles Only)

FIBER HOLE SIZE

- 126**
- 127**
- 128**
- 145**
- 162**
- 176**
- 232**
- 283**
- 1MM** Plastic optical fiber

CABLE TYPE

- Tight Buffered**
- 1-00** 900 tight buffered
- Tight Jacketed**
- 1-01** 2.5 mm OD
- 1-02** 1.8 mm OD
- 1-03** 3.0 mm OD
- 1-04** 2.1 mm OD
- 00** 2.2 mm OD (1MM Fiber Size Only)

Crimp Sleeves and Crimp Dies

Cable OD	Sleeve Part No.	Crimp Dies Part No.	A/F
900 μm Tight Buffer	—	455608	1.64/1.74 0.065/0.069
2.5	455610-01	455608	3.10/3.12 0.122 / 0.123
1.8	455610-02	455608	3.10/3.12 0.122/0.123
2.0	455610-03	455608	3.56/3.48 0.140/0.137
2.1	455610-04	455608	3.10/3.12 0.122/0.123

Millimeters Inches



SPACE SAVING

- Two optical channels in a size 9 shell

HIGH PERFORMANCE

- Compact 2.5-mm precision zirconia ceramic ferrules
- Lightweight aluminum shells
- MIL-DTL-38999 Series III anti-vibration coupling mechanism and tri-start thread

EASY TO USE

- Simple termination process and tooling
- Purpose designed inserts, and insert-to-insert keying aid precision alignment
- Identical spring loaded optical contacts help maintain contact under severe shock and vibration

DEUTSCH MC4 Duplex Connectors



MIL-DTL-38999 Style Series III Connectors

The MC4 Duplex optical fiber connector is based upon shell size 9 Mil-C-38999 Series III making this an extremely compact environmentally sealed 2-way connector. The MC4 is suitable for use with most multimode fibers with core diameters of 50 to 200 μm . Simplex and duplex cable constructions can be accommodated with suitable connector backshells.

Precision ceramic ferrules and alignment sleeves help support optimum performance and reliability over the service life of the connector.

The optical termini are spring loaded in both the plug and receptacle shells. This helps provide an axial load equalization so that the contact can be maintained even when the connector is subjected to vibration levels in excess of 30 g.

The coupling nut has a built in antivibration clicker mechanism to help prevent inadvertent uncoupling under adverse vibration conditions.



DEUTSCH MC4 Duplex Connectors

MIL-DTL-38999 Style Series III Connectors

Specifications

OPTICAL

- **Attenuation:** Less than 0.4 dB (50/125 μm)
- **Repeatability:** Better than 0.2 dB
- **Fiber Types:** x/125, 100/140, 200/280 μm
- **Cable Types:**
 - 2.5 mm tight jacketed
 - 4.5 mm duplex
 - For other cable sizes consult TE

MATERIALS

- **Shell:** Aluminum alloy, nickel plated
- **Ferrule:** Zirconia
- **Alignment Sleeve:** Zirconia
- **Seals:** Fluorosilicone
- **Backshell:** Aluminum alloy, nickel plated

MECHANICAL

- **Temperature Range:** -65°C to +155°C
(Cable and epoxy dependent)
- **Durability:** 500 mating cycles



DEUTSCH MC4 Duplex Connectors

MIL-DTL-38999 Style Series III Connectors

Part Numbering System

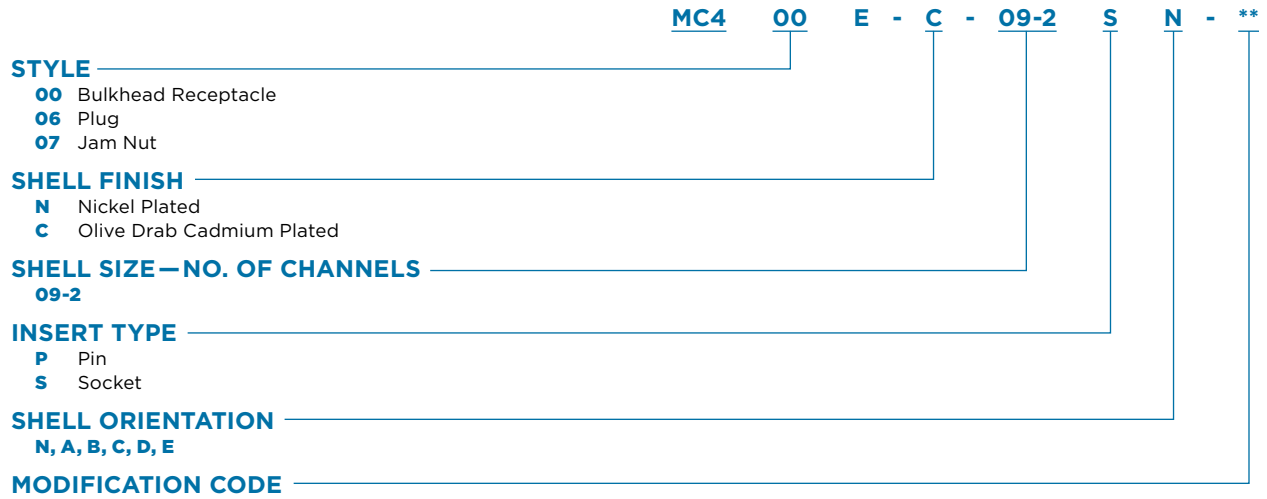

Jam Nut Receptacle

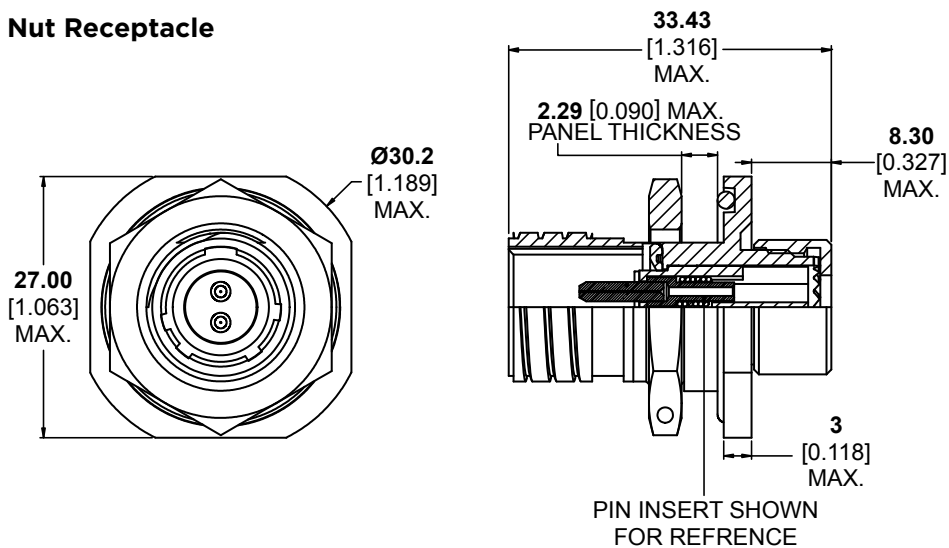



DEUTSCH MC4 Duplex Connectors

MIL-DTL-38999 Style Series III Connectors

Square Flange Receptacle

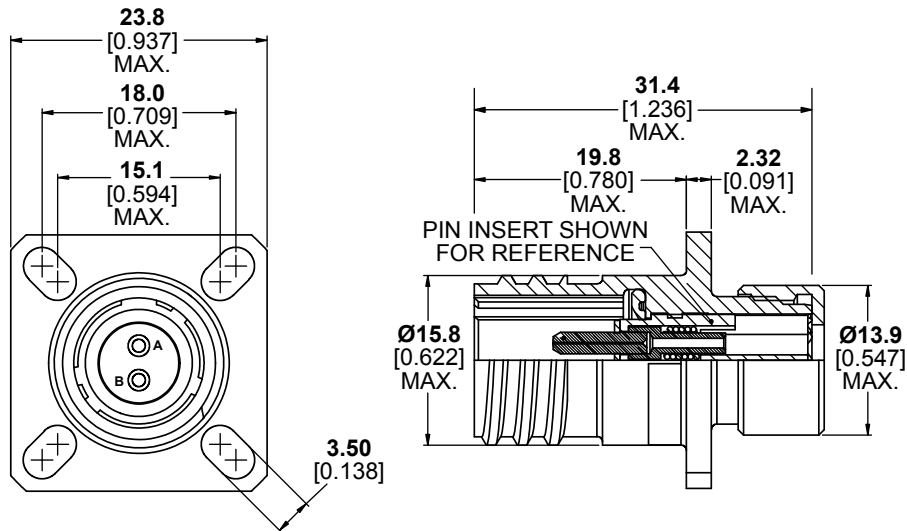

Plug

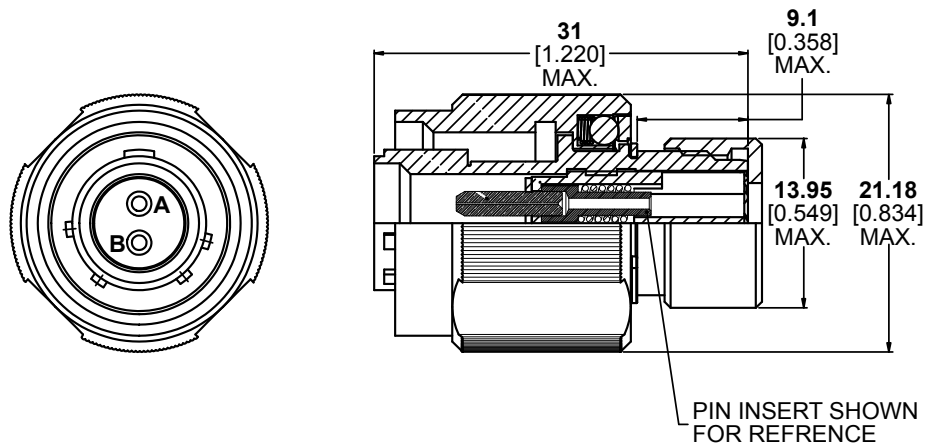



DEUTSCH MC4 Duplex Connectors

MIL-DTL-38999 Style Series III Connectors

Protective Cap for Receptacle Connectors

Part Numbering System

MC420E - N - 09

BASIC PART NUMBER

MC440E Pro Cap for Receptacle Connectors

MATERIAL/FINISH

- S Stainless Steel
- N Aluminum, Nickel Plated
- C Aluminum, Cadmium Plated

SHELL SIZE

09

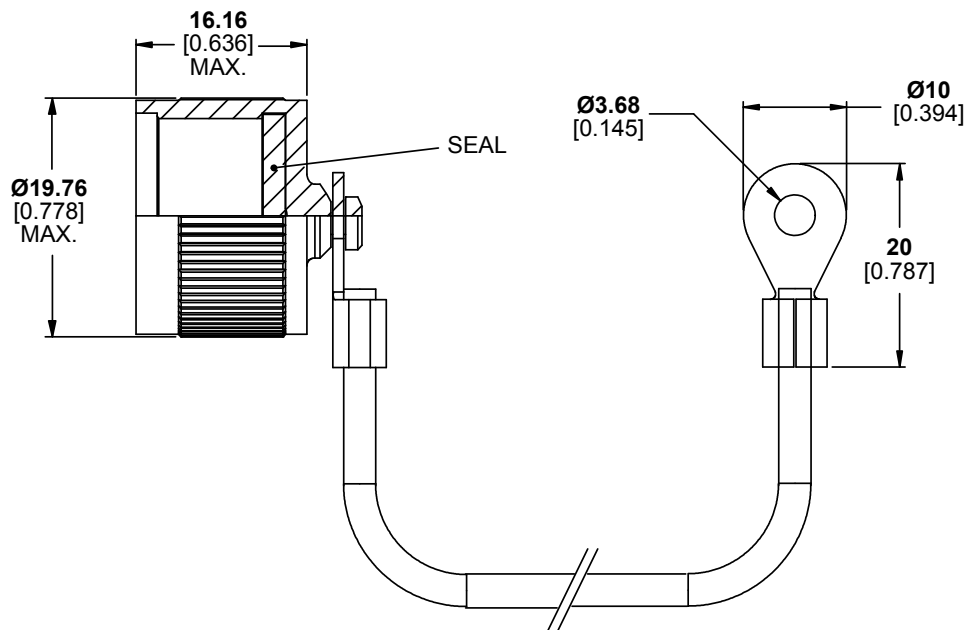



DEUTSCH MC4 Duplex Connectors

MIL-DTL-38999 Style Series III Connectors

Protective Caps for Plug Connectors

Part Numbering System

MC420E - N - 09 - N

BASIC PART NUMBER

MC420E Pro Cap for Plug Connectors

KEYING

N, A, B, C, D, E

SHELL SIZE

09

MATERIAL/FINISH

- S** Stainless Steel
- N** Aluminum, Nickel Plated
- C** Aluminum, Cadmium Plated

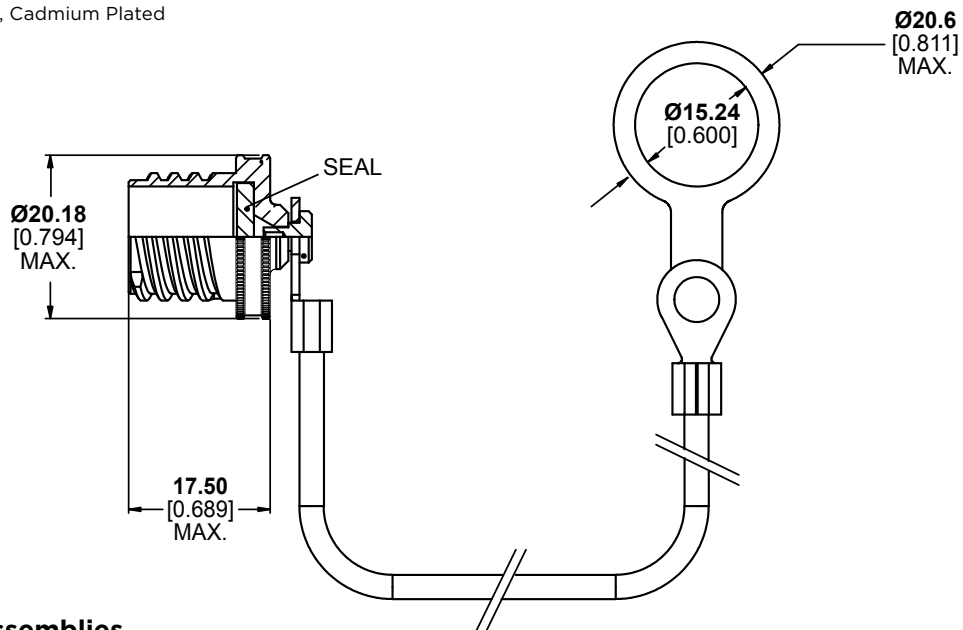

Back End Assemblies



HIGH PERFORMANCE

- Compact 1.25 mm precision zirconia ceramic ferrules
- Composite lightweight, high strength, corrosion resistant connector shells
- MIL-DTL-38999 Series III anti-vibration coupling mechanism and tri-start thread

EASY TO USE

- Simple termination process and tooling
- Purpose designed inserts, and insert-to-insert keying aid precision alignment
- Identical spring loaded optical contacts help maintain contact under severe shock and vibration

VERSATILE

- Extensive range: 1, 2, 4, 6, 8, 10, 18, 24 and 30 way connectors
- Choose from plug socket/ receptacle pin or plug pin/ receptacle socket configurations
- Easily removable alignment sleeve insert facilitates simple cleaning and maintenance

DEUTSCH MC5 Connectors



MIL-DTL-38999 Style Series III Connectors

The DEUTSCH MC5 high-density fiber optic multiway connector series from TE Connectivity (TE) is capable of sustained performance over a wide range of tough environmental conditions.

The MC5 connector uses precision ceramic ferrules and lightweight MIL-DTL-38999 Series III connector shell materials, combined with purpose-designed inserts to help ensure the optical performance meets the requirements of high reliability optical systems.

Compact spring-loaded precision optical contacts are individually insertable/removable for ease of assembly and maintenance, and the color band indicates full mating. The alignment sleeves provide highly reliable, repeatable optical performance.

The MC5 Series connectors provide excellent performance under some of the most demanding environmental conditions, including military aircraft.



DEUTSCH MC5 Connectors

MIL-DTL-38999 Style Series III Connectors

Specifications

FIBER TYPE

- **Channels:** 2, 4, 6, 8, 10, 18, 24, and 30 channels
- **Cable Size:** 1.8 mm, 2.1 mm and 2.5 mm jacket

MATERIALS

- **Shell:** Composite
- **Contact Body:** Arcap
- **Ferrules:** Zirconia
- **Alignment Sleeves:** Zirconia
- **Seals:** Fluorosilicone
- **Plating:** Nickel

OPTICAL PERFORMANCE

- **Insertion Loss:** 0.25 dB typical
- **Return Loss:** -40 dB typical
- **Repeatability:** 0.1 dB (with 50/125 μ m fiber)

TEMPERATURE

- **High Temperature Endurance:** +150°C, 760 hours
- **Low Temperature Endurance:** -65°C, 500 hours

MECHANICAL

- **Sine Vibration:** 5-3000 Hz, 40 g, 10 hours
- **Random Vibration:** 25-2000 Hz, 5 g²/Hz (50 Grms), 16 hours



DEUTSCH MC5 Connectors

MIL-DTL-38999 Style Series III Connectors

Ordering Information

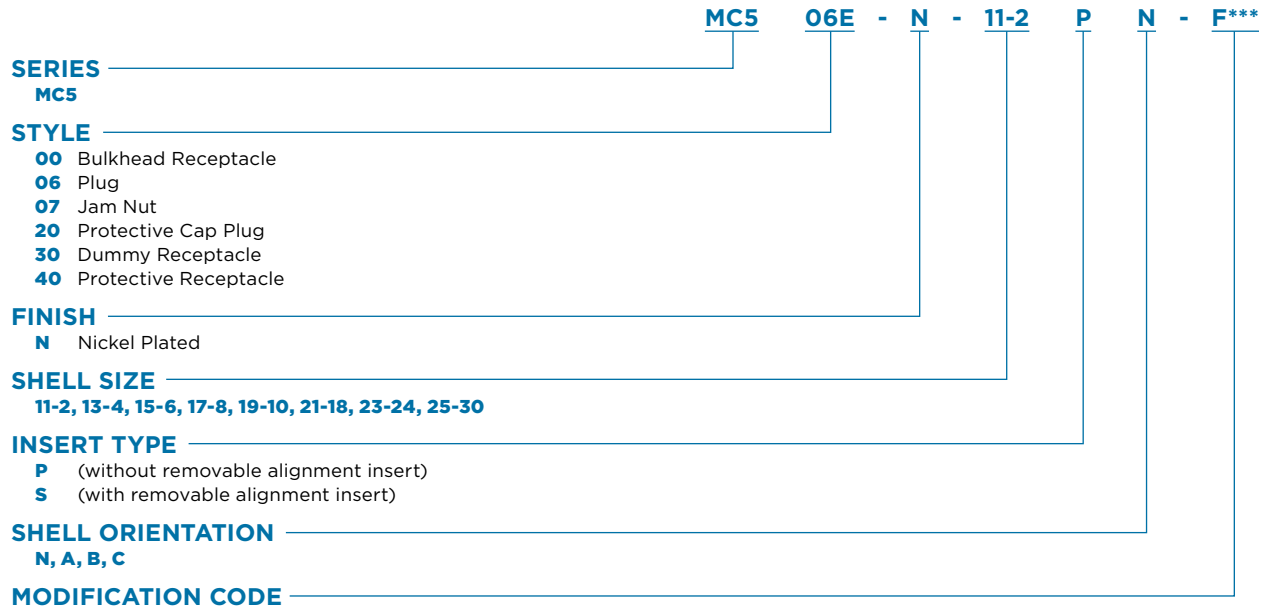

Plug
MC506E

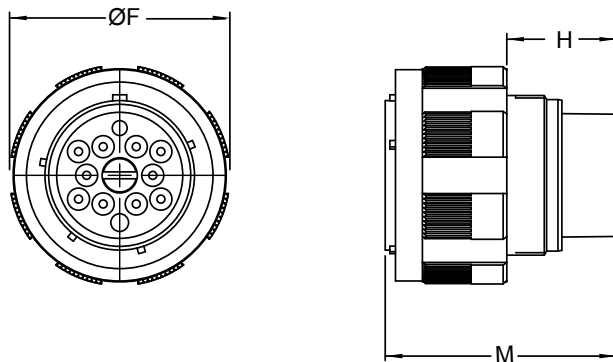

Dimensional Information

Size/ Arrangement	ØF Max.	H Max.	M Max.
11-2	24.94 0.982	19.9 0.783	40.86 1.609
13-4	29.34 1.155	19.9 0.783	40.86 1.609
15-6	32.46 1.278	19.9 0.783	40.86 1.609
17-8	35.66 1.404	19.9 0.783	40.86 1.609
19-10	38.46 1.514	19.7 0.776	40.86 1.609
21-18	41.66 1.640	19.7 0.776	40.86 1.609
23-24	44.86 1.766	19.7 0.776	40.86 1.609
25-30	47.98 1.889	19.7 0.776	40.86 1.609

Millimeters Inches



DEUTSCH MC5 Connectors

MIL-DTL-38999 Style Series III Connectors

Receptacle

MC500E

18.02

[0.71]
MAX.

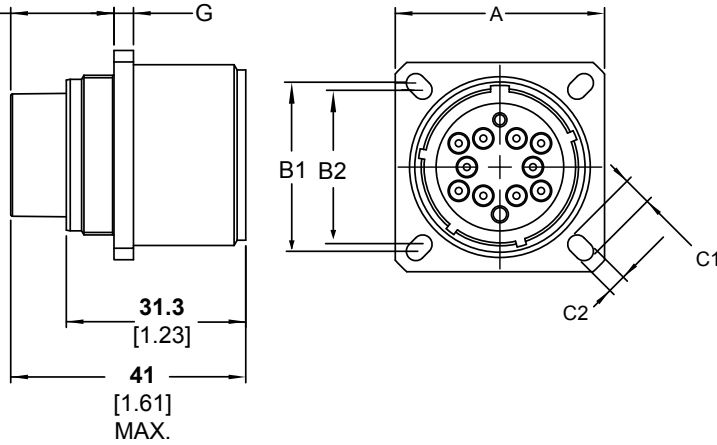

Dummy Receptacle

MC530E

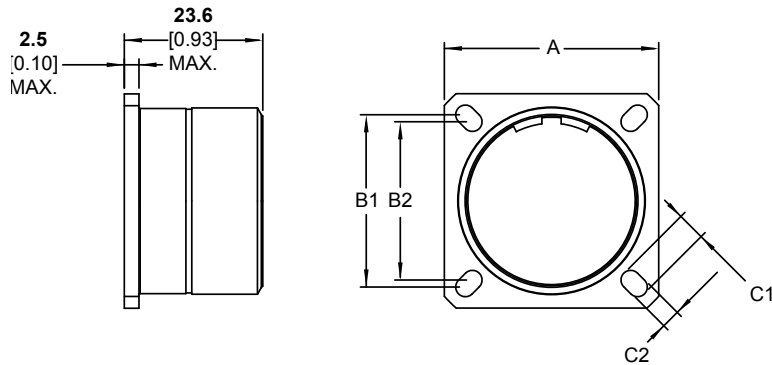

Size/ Arrangement	A Max.	B1	B2	C1 Min.	C2 Min.	G Max.
11-2	26.4 1.039	20.62 0.812	18.26 0.719	4.84 0.191	3.16 0.124	3.52 0.139
13-4	28.81 1.134	23.01 0.906	20.62 0.812	4.84 0.191	3.16 0.124	3.52 0.139
15-6	31.2 1.228	24.61 0.969	23.01 0.906	4.31 0.170	3.16 0.124	3.52 0.139
17-8	33.51 1.319	26.97 1.062	24.61 0.969	4.84 0.191	3.16 0.124	3.52 0.139
19-10	36.71 1.445	29.36 1.156	26.97 1.062	4.84 0.191	3.16 0.124	3.52 0.139
21-18	39.91 1.571	31.75 1.250	29.36 1.156	4.84 0.191	3.16 0.124	4.33 0.170
23-24	43.11 1.697	34.93 1.375	31.75 1.250	6.06 0.239	3.83 0.151	4.33 0.170
25-30	46.21 1.819	38.1 1.500	34.93 1.375	6.06 0.239	3.83 0.151	4.33 0.170

Millimeters Inches



DEUTSCH MC5 Connectors

MIL-DTL-38999 Style Series III Connectors

Procap
MC520E

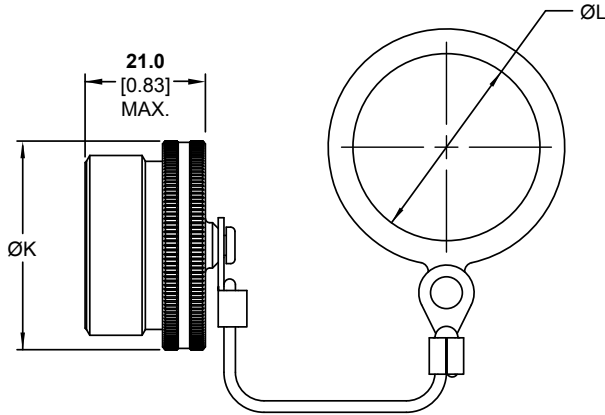

Procap
MC540E

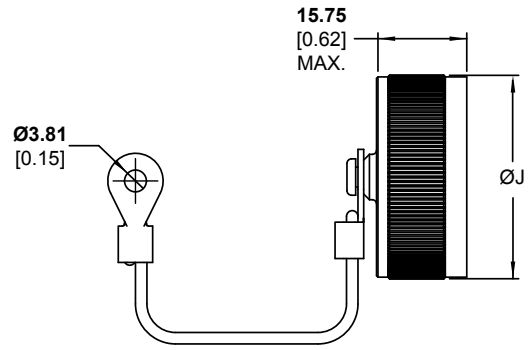

Size/ Arrangement	ØJ Max.	ØK Max.	ØL Min.
11-2	22.96 0.094	24.00 0.945	16.51 0.650
13-4	26.06 1.206	27.56 1.085	19.56 0.770
15-6	29.26 1.152	31.10 1.224	22.86 0.900
17-8	34.16 1.345	35.46 1.396	26.04 1.025
19-10	35.66 1.404	37.16 1.463	29.21 1.150
21-18	38.75 1.526	40.10 1.579	32.39 1.275
23-24	42.06 1.656	43.36 1.707	35.56 1.400
25-30	44.96 1.770	46.6 1.835	38.74 1.525

Millimeters Inches



DEUTSCH MC5 Connectors

MIL-DTL-38999 Style Series III Connectors

MC5 Optical Termini (ordered separately)

Optical termini are supplied with a profile formed optical end face and are available for single-mode or multimode fibers. Contacts are available in either spring-loaded or rigid versions, depending upon application. Rigid contacts should be used in bulkhead receptacles only.

Note: A crimp sleeve is not included for terminating 900- μ m buffered cable.

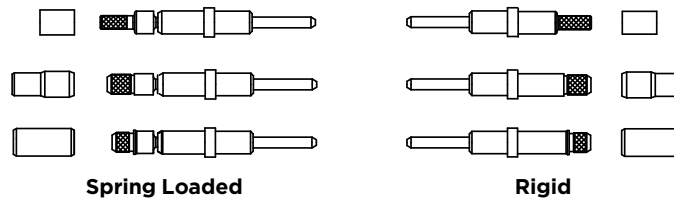

Ordering Information

	455335 - 126 1-01
TERMINUS TYPE	
455335 Spring Loaded	
455360 Rigid	
FERRULE FIBER HOLE SIZE (μM)	
125	
126	
127	
128	
144	
159	
172	
175	
CABLE JACKET DIAMETER	
1-00 900 μ m Buffer	
1-01 2.1 mm Dia.	
1-02 1.8 mm Dia.	
1-03 2.5 mm Dia.	

Tooling

- **Crimp Tool:** Part No. 471716
- **Crimping Dies:** 457440

MC5 Backshells for Multifiber Cables (ordered separately)

A variety of backshells are available for multifiber cables, with peripheral strain relief (for 900- μ m buffered cable) and central strain relief. Consult TE.



EASY TO USE

- Insert-to-insert keying aids in precision alignment
- Individually rear insertable and removable optical contacts
- Color band indicates full mating
- Easily accessible APC and PC end faces for cleaning and maintenance

VERSATILE

- Interchangeable with MIL-DTL-38999 Series III
- Backshells and adapters available for most single and multifiber cable types
- Insert accommodates 2 to 72 channels, and can be supplied pre-terminated
- Standard MT interface and multiple housing options help make integration into new and existing systems easy

RUGGED

- Lightweight, corrosion-resistant metal-plated composite shell
- Strong, durable and environmentally sealed
- Anti-vibration coupling with tri-start thread

DEUTSCH MC6 Fiber Optic Ribbon Cable Connectors



38999 Series III-Style Connectors

The DEUTSCH MC6 high-density fiber optic connector series is rugged, versatile, and easy to install and maintain. The connectors are compatible with standard MT ferrule inserts.

The MT ferrule inserts accommodate 2 to 72 channels and can be supplied pre-terminated, if required. The MC6 connector uses the compact MIL-DTL-38999 Series III, shell size 11 body, which is also used on the DEUTSCH MC5 connector.

MC6 connectors have a lightweight, corrosion resistant, metal-plated composite shell, which helps provide high strength and durability combined with excellent EMC shielding. MC6 connector shell are also available in aluminum and Marine Bronze materials

The result is a very compact, rugged, environmentally sealed solution for a wide range of applications, such as avionics, data bus and in-flight entertainment systems.



DEUTSCH MC6 Fiber Optic Ribbon Cable Connectors

38999 Series III-Style Connectors

Specifications

MATERIALS

- **Shell:** Aluminum, composite or Marine Bronze
- **Contact Body:** Nickel/cadmium plated composite polymer
- **Ferrule:** Thermoplastic
- **Alignment Pin:** Stainless steel
- **Seals:** Fluorinated silicone elastomer
- **Plating:** Nickel (Back zinc nickel available for aluminum shells)

OPTICAL

- **Insertion Loss:** 0.25 dB typ. (fiber dependent)
- **Return Loss:** -40 dB typ.
- **Repeatability:** 0.2 dB typ.

ENVIRONMENTAL/MECHANICAL

- **Temperature Range:** -55°C to +150°C
- **Vibration:** 20 to 2000 Hz, 20 g
- **Durability:** 500 mating cycles

FIBER TYPE

- **Channels:** 2 to 72
- **Cable Type:** Telecom grade cable
Aerospace grade cable

Thread Sizes

Shell Size	Accessory Thread (6g .100R)	Mating Thread (0.1P-0.3L)	Jam Nut Thread (6g .100R)
11	M15 x 1.0	.7500	M20 x 1.0



DEUTSCH MC6 Fiber Optic Ribbon Cable Connectors

38999 Series III-Style Connectors

Connector Part Numbering



MT Ferrule Part Numbering

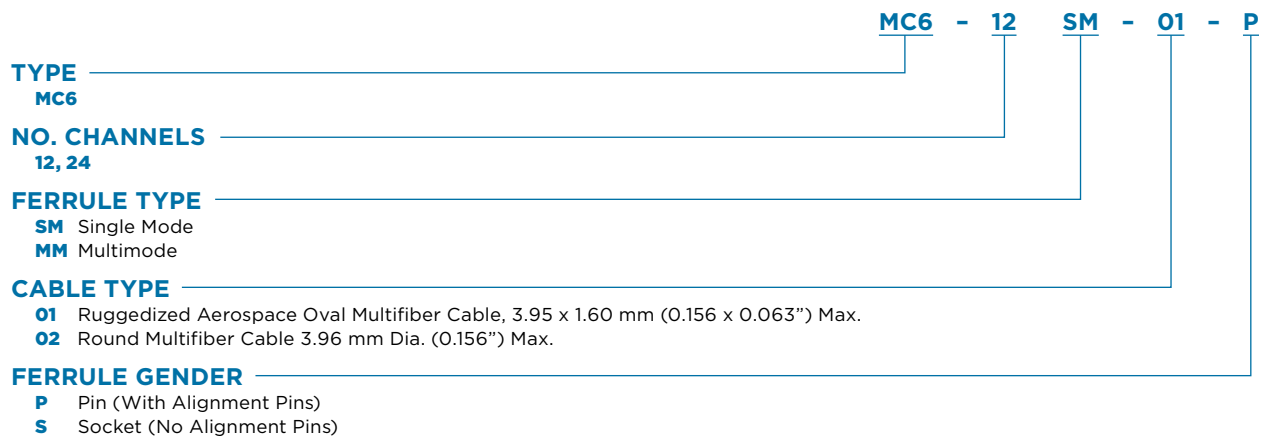



DEUTSCH MC6 Fiber Optic Ribbon Cable Connectors

38999 Series III-Style Connectors

Square Flange Receptacle

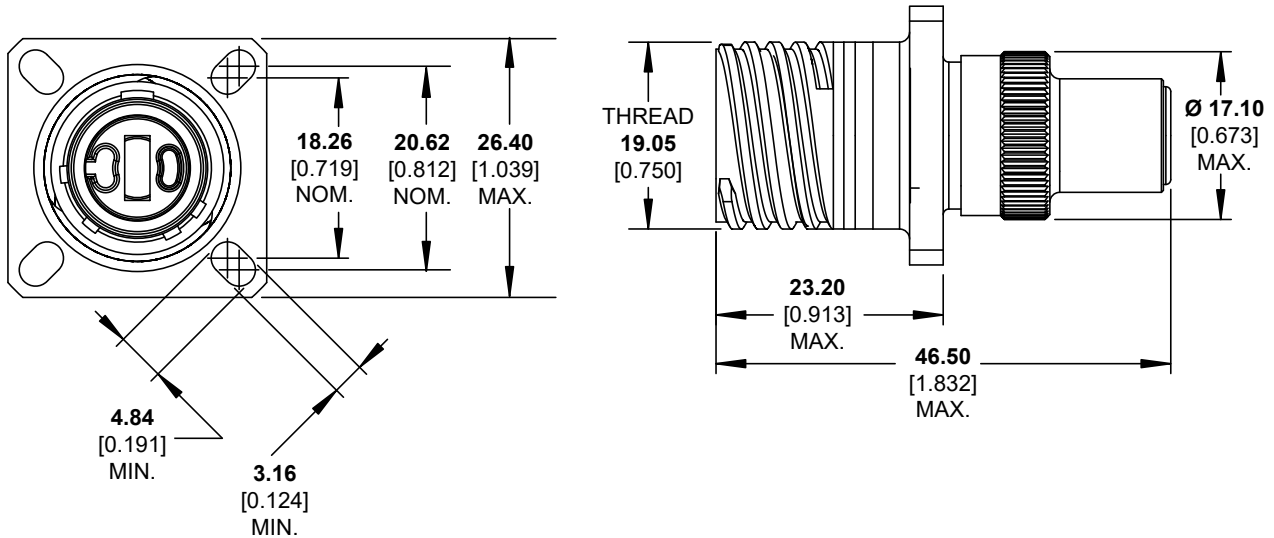

Jam Nut Receptacle

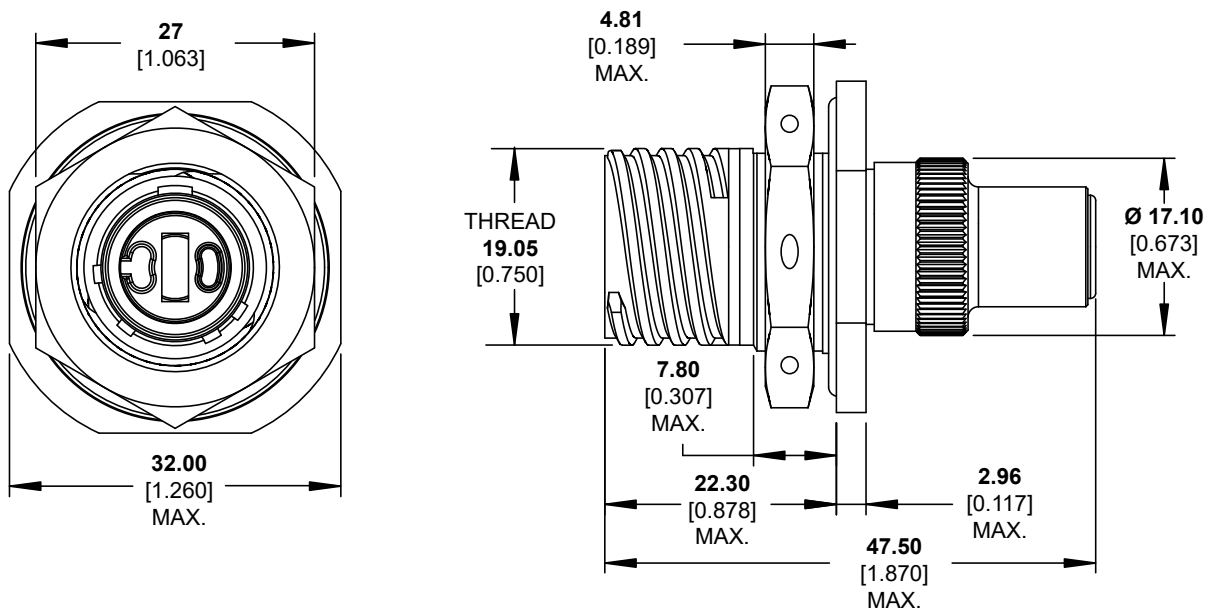



DEUTSCH MC6 Fiber Optic Ribbon Cable Connectors

38999 Series III-Style Connectors

Plug

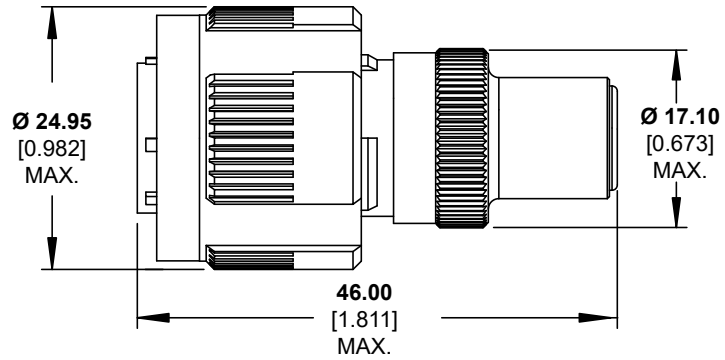
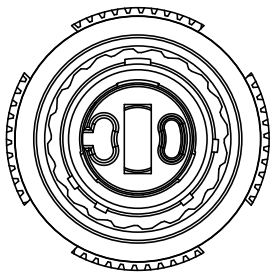

Dummy Receptacle

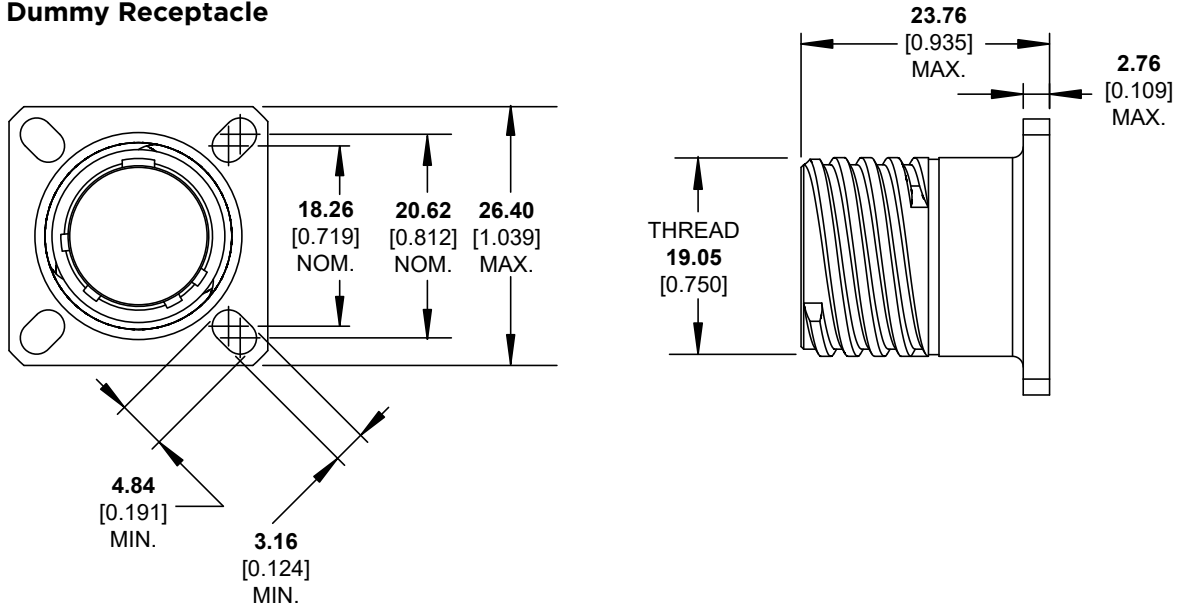



DEUTSCH MC6 Fiber Optic Ribbon Cable Connectors

38999 Series III-Style Connectors

Protective Caps for Receptacles

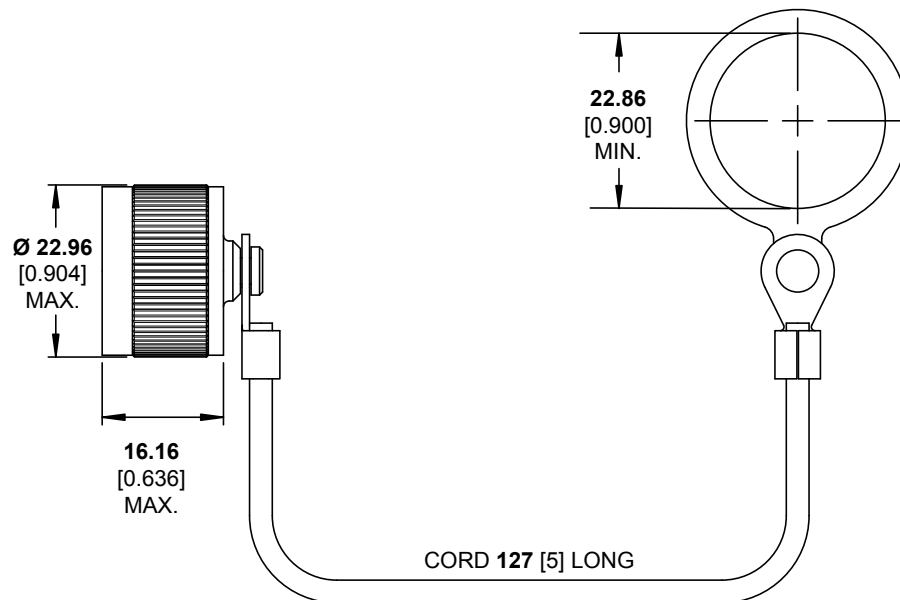
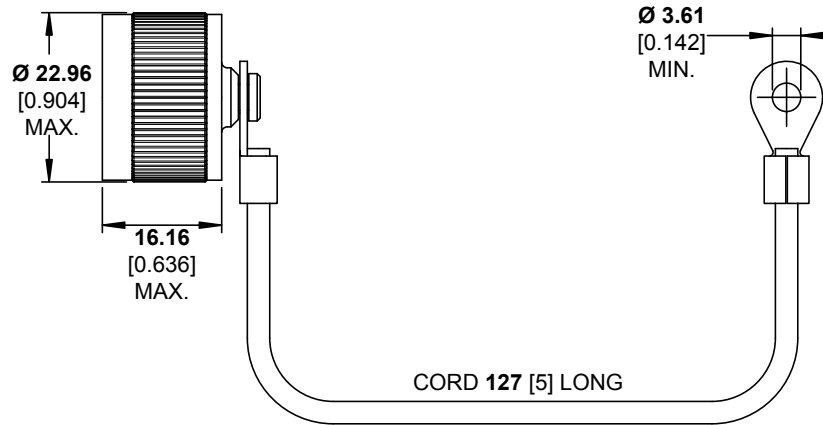



DEUTSCH MC6 Fiber Optic Ribbon Cable Connectors

38999 Series III-Style Connectors

Protective Caps for Plugs

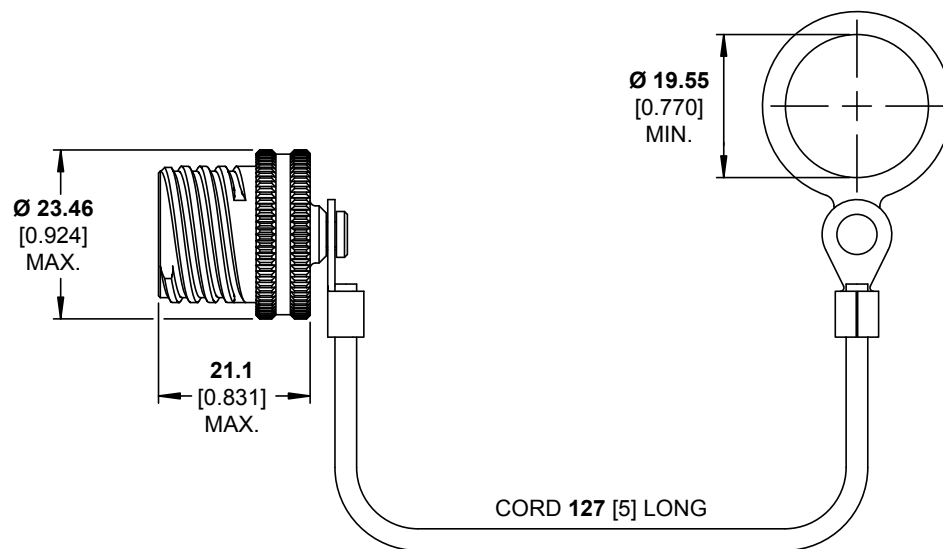



HIGH CAPACITY

- Holds four 12 or 24-fiber MT ferrules
- Up to 96 optical channels per connector
- Size 21 shell

EASY TO ASSEMBLE

- No special tools or fixtures required
- Only one part to assemble: the ferrule retainer to secure the ferrule
- Screwdriver is only tool required

HIGH PERFORMANCE

- Precision alignment for excellent optical performance
- Vibration resistant

COMPATIBLE

- Uses standard 38999 backshells

AviMT Connector



D38999 Series III Style Connector with Four MT Ferrules

The AviMT connector from TE Connectivity (TE) holds four MT ferrules—for up to 96 fibers—in a compact size 21 shell. The connector is well suited to applications requiring high fiber counts, such as UAV-based video surveillance, C5ISR, avionics, fiber backbone, radar and IFE systems.

Fast, Simple Assembly

The connector is very easily assembled, requiring only a screwdriver to fasten the ferrule retainer into place. The simple assembly contrasts dramatically with many connectors in the industry, which require special tools and fixtures to assemble multiple parts and subassemblies.

Specifications

MATERIALS

- **Shell:** Nickel-plated aluminum (Consult TE for other shell finishes)
- **Insert:** Thermoplastic
- **Front Retainer Ring:** Passivated stainless steel
- **Interfacial Seal:** Rubber
- **Ferrule Retainer:** Passivated stainless steel

OPTICAL (Tested with OM3 multimode fiber)

- **Insertion Loss (Avg.)**
12-Fiber Ferrule: 0.12 dB
24 Fiber Ferrule: 0.17 dB
- **Return Loss (Avg.)**
12-Fiber Ferrule: 29.3 dB
24 Fiber Ferrule: 29.8 dB

ENVIRONMENTAL/MECHANICAL

- **Low Temp Storage:** -50°C for 96 hours
- **High Temp Storage:** +85°C for 96 hours
- **Humidity Exposure:** Cycled to +55°C, 95% RH
- **Thermal Cycling:** -40°C to 70°C
- **Sine Sweep Vibration:** 10 Hz to 2000 Hz, 15 g peak
- **Random Vibration:** 16.91 grms
- **Mechanical Shock:** 50g

APPLICATIONS

- C5ISR
- Avionics
- Military aerospace
- Commercial aerospace ground radar
- Fiber backbone
- IFE systems



AviMT Connector

D38999 Series III Style Connector with Four MT Ferrules

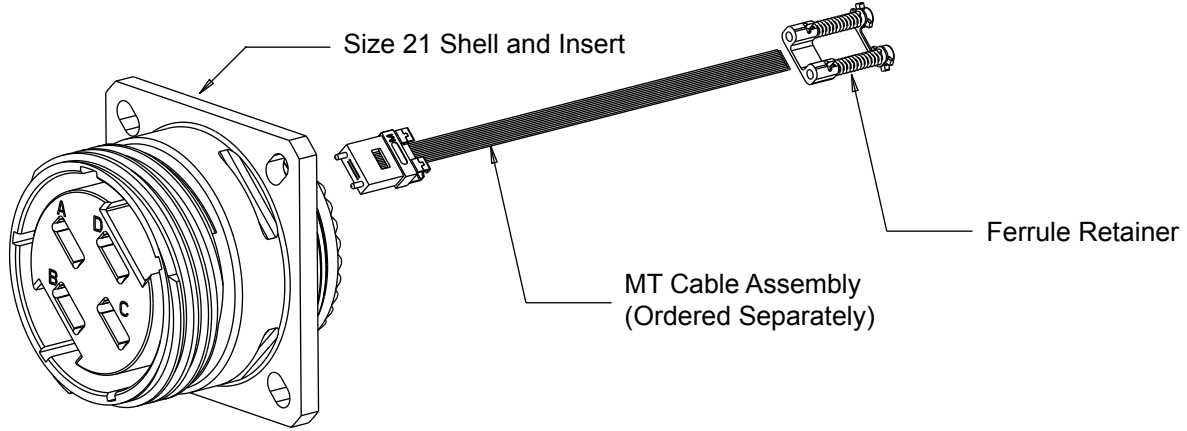

Ordering Information

Style	Part No.
Plug	2828342-1
Square Flange Receptacle	2828343-1
Jam Nut Receptacle	2320289-1

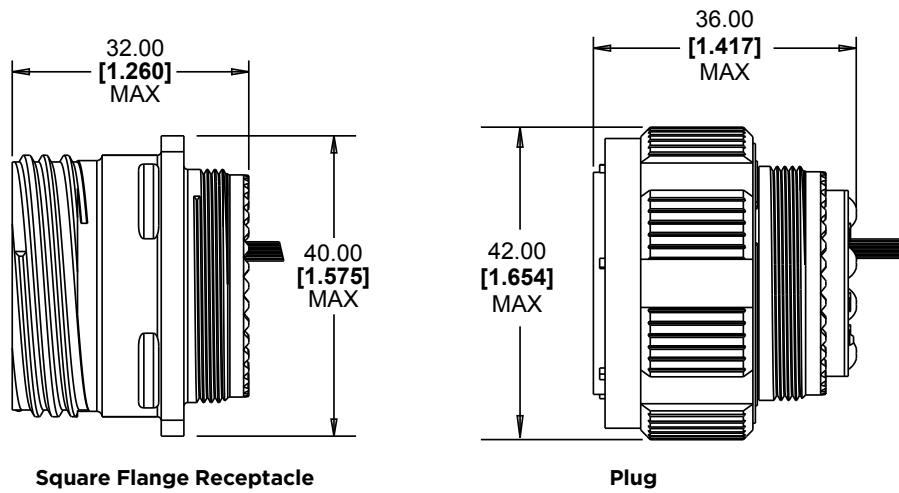



RUGGED

- Noncontacting fiber interface
- Minimal wear on fiber optic interface
- Vibration resistant

EASY TO USE

- Easy to handle
- Easy to clean
- Highly resistant to dirt/debris

CONSISTENT

- Repeatable low-loss performance in harsh environments
- Low sensitivity to thermal fluctuations and interface contamination
- Consistent overall optical link budget

VERSATILE

- Single mode or multimode
- Common 850/1300 dual, 1310, or 1550 nm wavelengths
- 2 or 4 optical channels in a size 15 shell
- 8 channels in a size 15 shell

38999-Style Connectors



Expanded beam inserts for 38999-style connectors use the same reliable insert technology as our PRO BEAM connectors. Available to accommodate 2 or 4 optical channels in a size 11 shell or 8 channels in a size 15 shell, the inserts give you many of the advantages of expanded beam interfaces in the familiar 38999 form factor.

Connector kits are available to accommodate popular fiber optic cable styles used in the military and aerospace industry—including tactical cable, 1.8 and 2.2-mm avionics cable, and buffered-only cable.

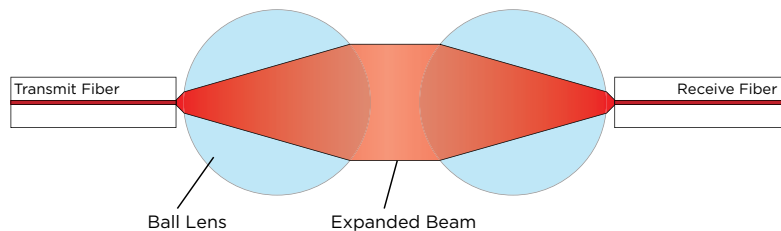

Expanded beam technology, which physically expands and collimates the transmission signal into an optical beam over 14 times its original diameter for multimode fiber and over 45 times for single-mode fiber. The beam is then refocused back down onto the core of the receiving fiber. This approach provides ease of alignment and low sensitivity to thermal changes and contamination.



38999-Style Connectors with Expanded Beam Inserts

Standard Styles

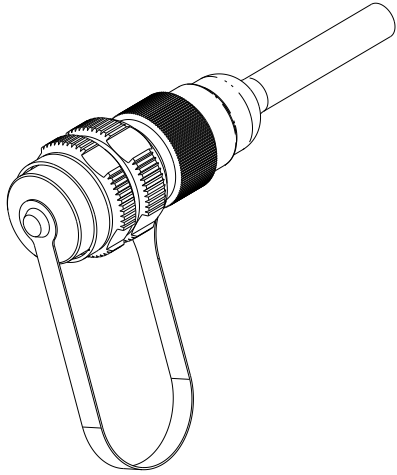

Plug Connector

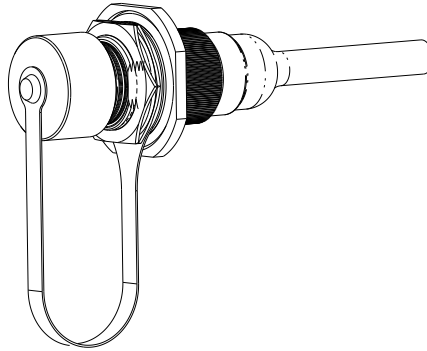

Jam Nut Receptacle Connector

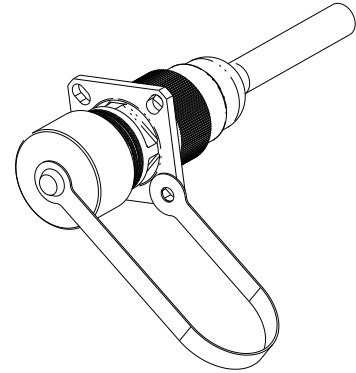

Square Flange Receptacle

Insert Kits

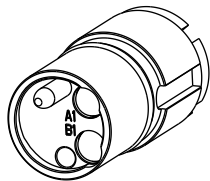

2-Channel Mini Insert
(Size 11 Shell)

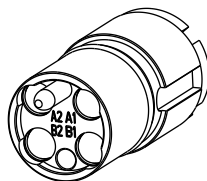

4 Channel Mini Insert
(Size 11 Shell)

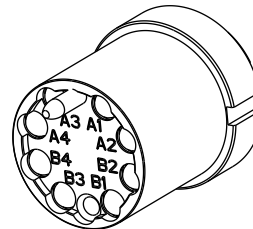

8-Channel Sr. Insert
(Size 15 Shell)

EB Insert Type	No. of Fibers	Part No.		
		Multimode 850/1300 nm	Single Mode 1310 nm	Single Mode 1550 nm
Mini	2	1374759-4	1588129-2	1588128-2
	4	1374759-2	1588129-3	1588128-3
Sr.	8	1516256-1	1516258-1	1516258-2



38999-Style Connectors with Expanded Beam Inserts

Shell Kits

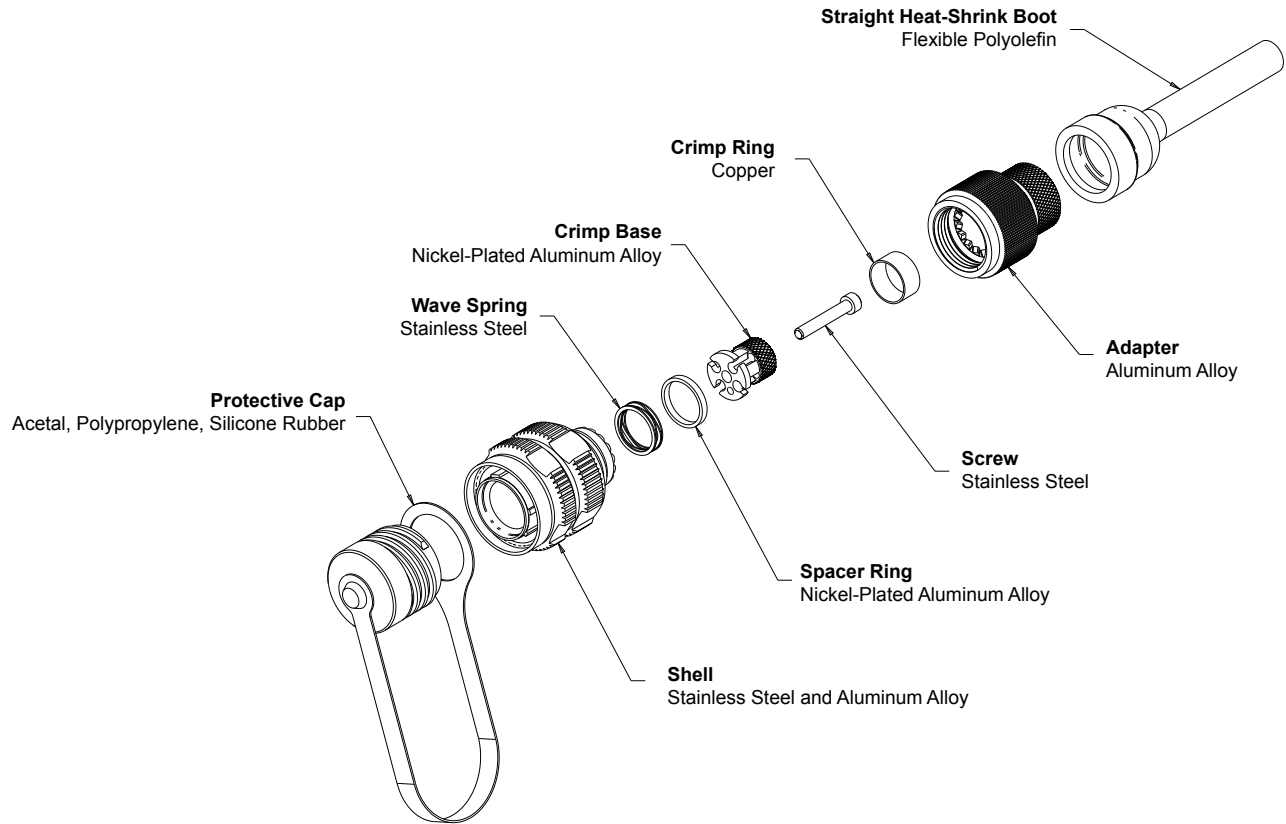

Typical Configuration and Materials
(Plug Connector Shown)



38999-Style Connectors with Expanded Beam Inserts

Ferrule Kits

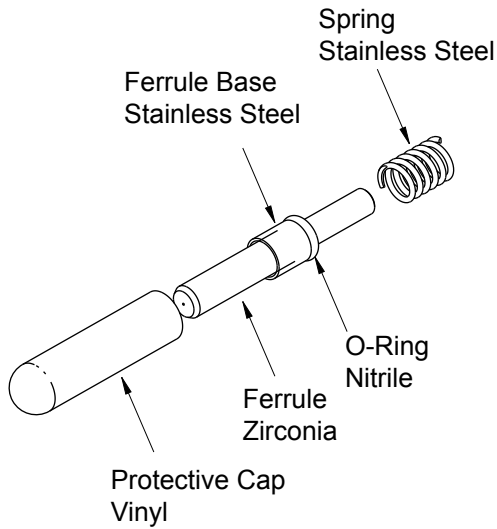

Fiber Hole Size (μm)	Fiber Type	Part No.	
		Mini	Sr.
125	Single Mode	1754700-1	1985635-1
126	Single Mode	1754700-2	1985635-2
	Multimode	1754699-1	1985107-1

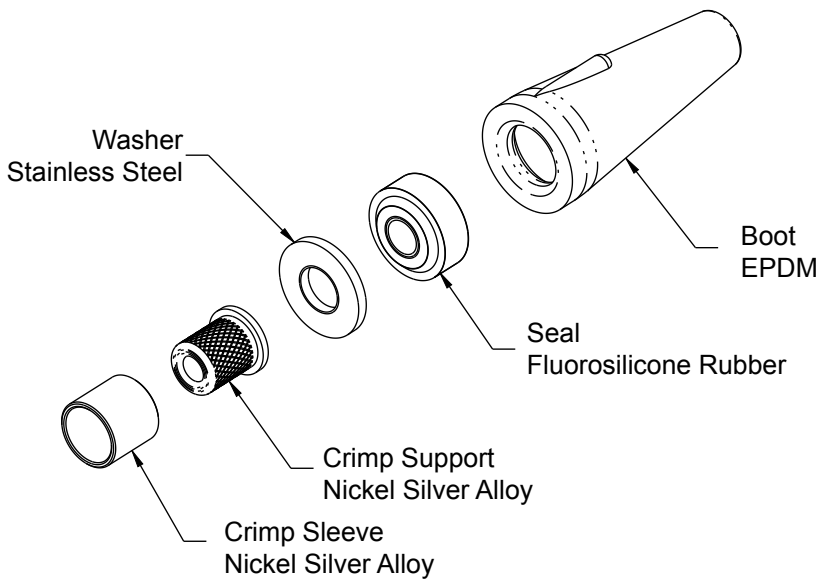

Cable Dia.	Part No.
5.1 mm	1516228-1
5.6 mm	1516228-2
6.2 mm	1516228-3



38999-Style Connectors with Expanded Beam Inserts

Shell Kits (Plug Connector Shown) Typical Configuration and Materials

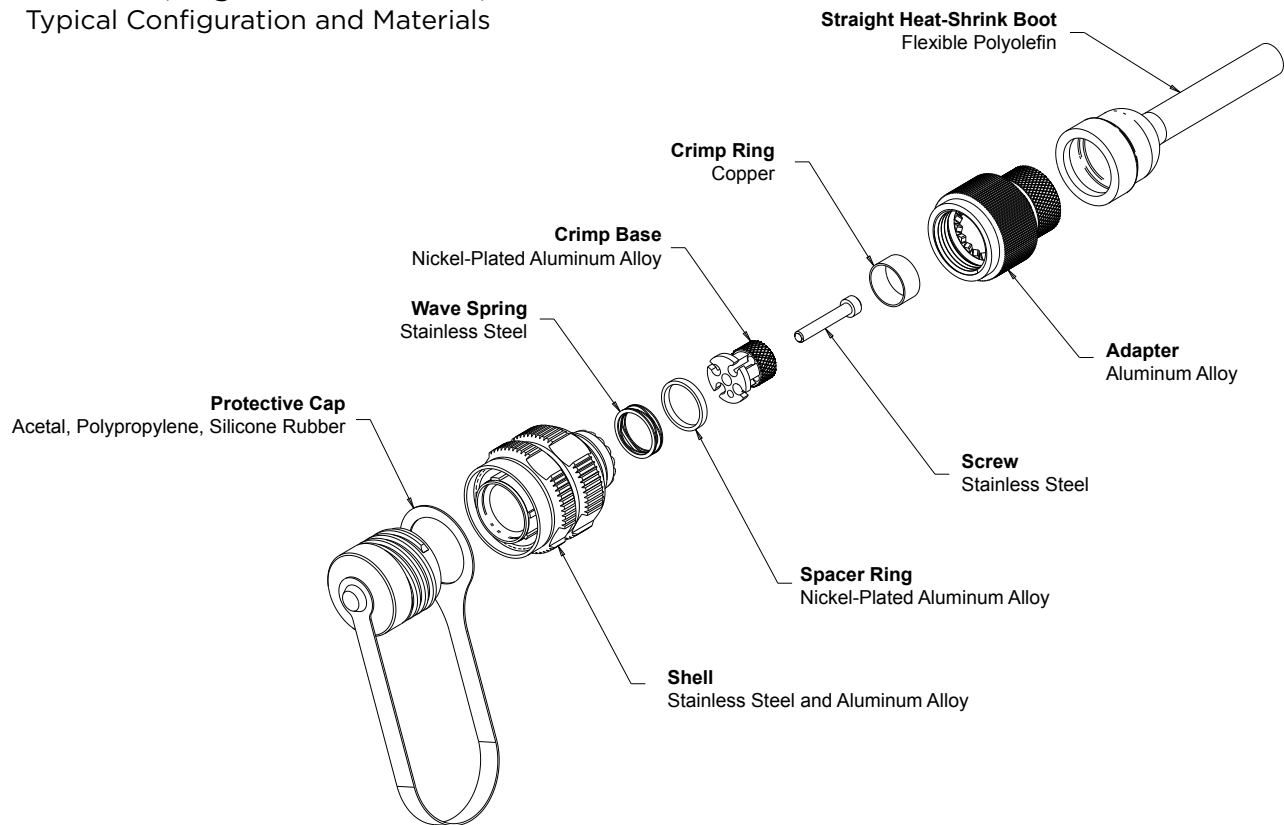

Shell Kits

Part numbers are for N keyed connectors with black zinc nickel finish. Consult TE for other keying and plating options.

Shell Size 11 Kit

Connector Style	Part No.		
	1.8 mm Avionics Cable	Mil Tactical Distrib. Cable	Buffered Fiber
Plug	6754518-7	1-1985021-3	1-1918883-3
Jam Nut Receptacle	6754519-7	1-2064163-3	1-1918884-3
Flange-Mount Receptacle	—	1-2064166-3	1-1918885-3

Shell Size 15 Kit

Connector Style	Part No.	
	2.2 mm Avionics Cable	End Nut Backshell for Non-Jacketed Cable
Plug	1516342-7	1516338-7
Jam Nut Receptacle	1516343-7	1516339-7
Flange-Mount Receptacle	1516344-7	1516340-7



38999-Style Connectors with Expanded Beam Inserts

Plug

Shell Size 11

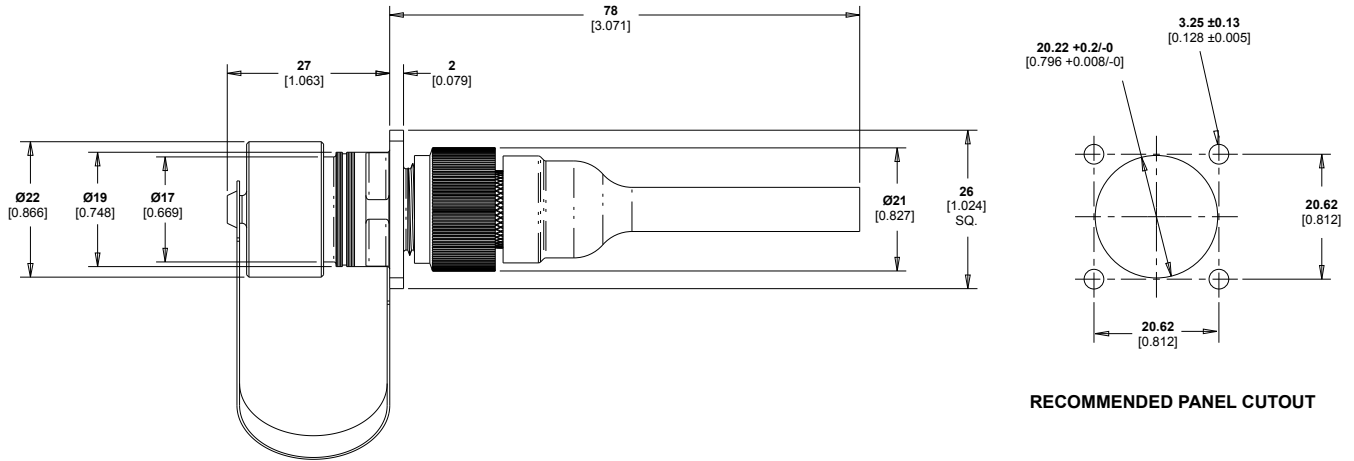

Jam Nut Receptacle

Shell Size 11

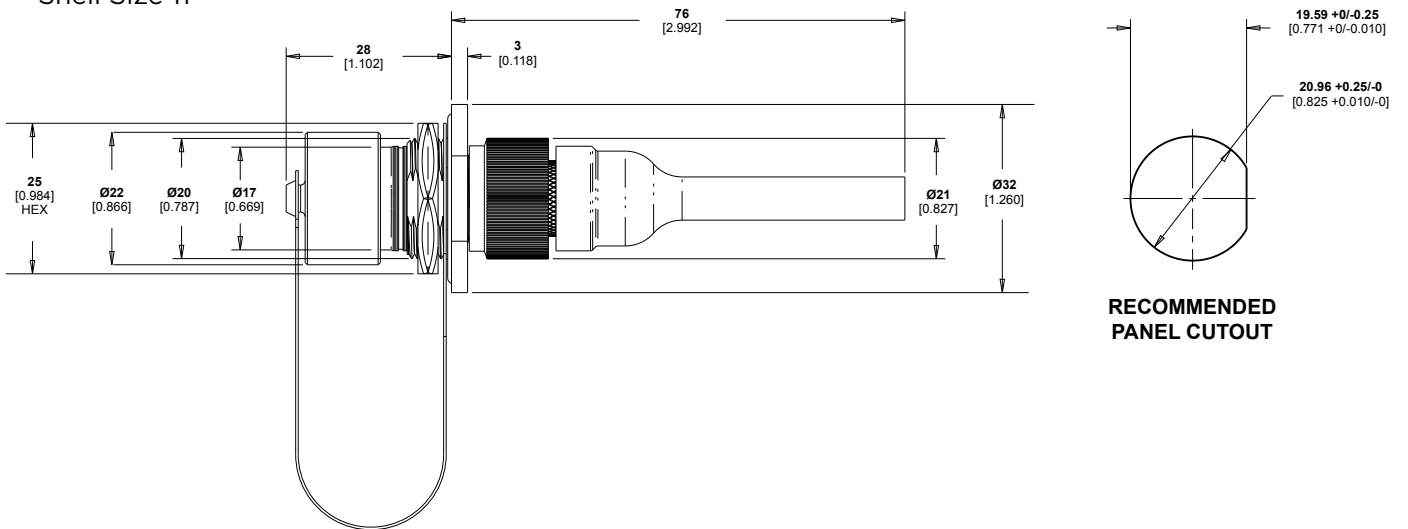



38999-Style Connectors with Expanded Beam Inserts

Square Flange Receptacle Shell Size 11

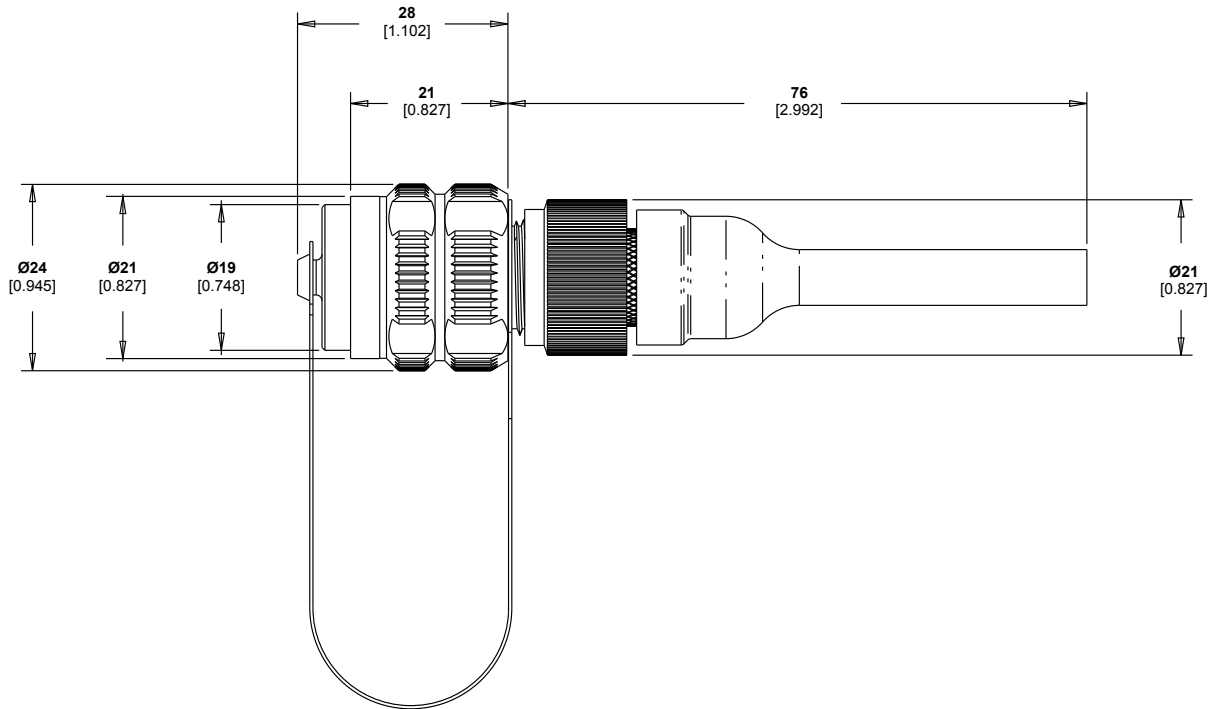

Recommended Panels Cutouts

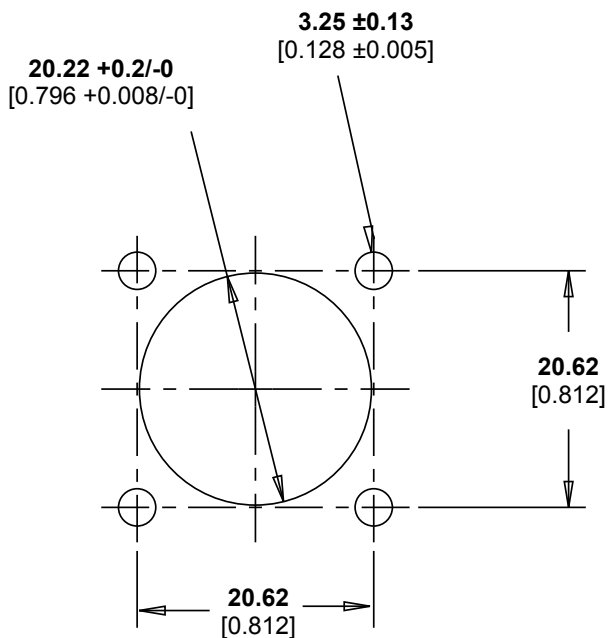

Square Flange Receptacle

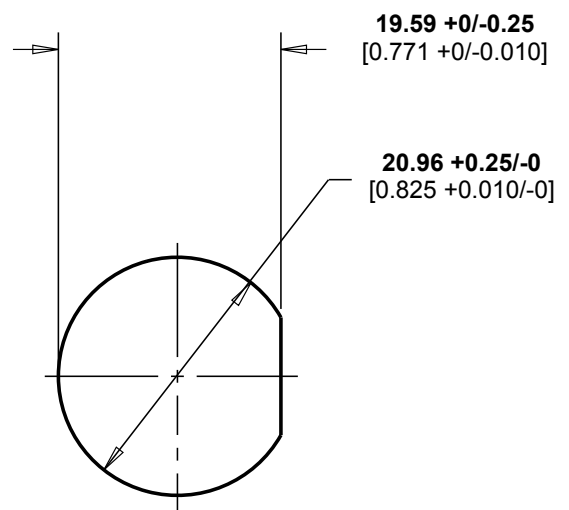

Jam Nut Receptacle



INDUSTRY STANDARDIZATION

- Selected for the ARINC 845 standard

DURABLE

- Minimal wear on fiber optic Interface
- Vibration resistant
- Resistant to dirt and debris

REPEATABLE LOW-LOSS PERFORMANCE

- Low sensitivity to thermal fluctuations and interface contamination
- Consistent overall optical “link budget”
- Stable operation over life of system

EASY TO USE

- Drop-in replacement for M29504/4 and /5 physical contact termini
- Durable non-contacting interface helps ensure ease of use/cleaning
- Simplified cleaning process

VERSATILE

- Fit standard size 16 cavity
- Field terminable

PRO BEAM EB16 Optical Termini



Bring Rugged Optical Performance to Mil-Standard Connectors

Leveraging our industry-accepted PRO BEAM expanded beam technology, the PRO BEAM EB16 termini are adding rugged, reliable optical performance to familiar Mil Spec connectors. The EB16 termini are a size 16 optical contact, fit-form compliant to MIL-DTL-38999 Series III size 16 cavities. These termini are a drop-in replacement for the M29504/4 and /5 physical contact termini used in many ruggedized circular connector systems.

Non-Contacting Interface

The non-contacting interface typically results in less wear and tear overall, especially in high-mating cycle or high-vibration applications.

The termini's ball lens physically expands and collimates the optical signal into an optical beam well beyond its original size to help provide easier optical alignment, lowers sensitivity to contamination, and helps provide consistent performance over thermal changes. The beam is then refocused back down onto the core of the receiving fiber.

The beam area is expanded 30 times between lenses. The signal will not deteriorate by airborne contamination particles of the same size that affect the performance of the PC connection. The termini's endface is easily cleaned.



PRO BEAM EB16 Optical Termini



Specifications

MATERIALS

- **Terminus Body and Crimp Sleeve:** Nickel-plated brass
- **Ferrule and Split Sleeve:** Zirconia
- **Ball Lens:** Glass, with antireflection coating
- **Spacer:** Stainless steel
- **Spring:** Stainless steel
- **Protective Cap:** Vinyl

MECHANICAL/ENVIRONMENTAL

- **Durability:** >1000 mating cycles
- **Operating Temperature:** -65°C to +165°C (Cable dependent)
- **Sinusoidal Vibration:** TIA/EIA-455-11C, Test Condition IV
- **Random Vibration:** TIA/EIA-455-11C, Test Condition VI-J
- **Mechanical Shock:** TIA/EIA-455-14A, Test Condition C
- **Thermal Cycling:** TIA/EIA-455-3B, Test Condition C-2
- **Thermal Shock:** TIA/EIA-455-71, Schedule C-0 (5 cycles)

OPTICAL

- **Insertion Loss:** 1.5 dB max. @ 850/1300 nm (Multimode fiber)

STANDARDS

- **Industry Standards:** SAE AS3 AS6250, AS6251, and ARINC 845
- **TE Application Specification:** 108-127013
- **TE Instruction Sheet:** 408-32132
- **TE Qualification Test Report:** 501-32028

APPLICATIONS

- Radar and Sensor Systems
- Rugged Network Applications
- Fixed Wing and Rotary Aircraft
- Unmanned Systems
- Commercial Aviation

Type	Part No.
Pin	2125059-1
Socket	2125046-1

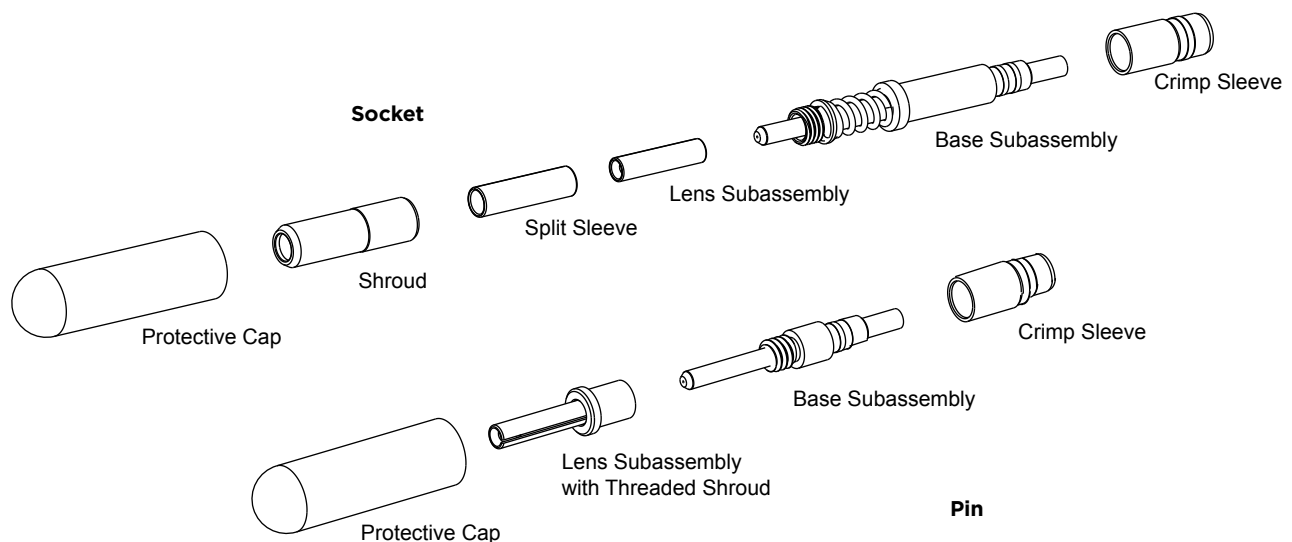



MIL SPEC

- Manufactured to meet the requirements of MIL-T-29504/4 and 5
- Designed for use in any MIL-DTL-38999 Size 16 cavity

HIGH PERFORMANCE

- Widely used in both rotary and fixed-wing aerospace applications
- Spring-loaded socket contacts help ensure consistent mating pressure and performance levels

MIL-T-29504 Style Optical Termini



Widely used in rotary and fixed-wing aerospace applications, our rugged optical termini is rated for 500 mating cycles and feature spring-loaded socket contacts to help ensure consistent mating pressure and performance levels. They are designed for use in any MIL-DTL-38999 Size 16 cavity, and manufactured to meet MIL-T-29504/4 and/5 requirements.

Specifications

FIBER TYPES

- **Single Mode:** 9/125 μm
- **Multimode:** 50/125, 62.5/125, 200/280 μm
- **Cable Size:** 1.8 mm, 2.5 mm

OPTICAL PERFORMANCE

(Depends on fiber type and finish)

- **Insertion Loss:** 0.6 dB typical
- **Return Loss:** -40 dB typical
- **Repeatability:** 0.2 dB typical

MATERIALS

- **Ferrule:** Zirconia
- **Alignment Sleeve:** Ceramic zirconia
- **Spring:** Stainless steel
- **Terminus Assembly:** ARCAP alloy
- **Heat Shrink Sleeve:** PVDF

ENVIRONMENTAL/MECHANICAL

- **Temperature Range:** -55°C to +150°C
- **Durability:** 500 mating cycles
- **Vibration:** 20 g, 20 to 2000 Hz



MIL-T-29504 Style Optical Termini

Socket (457462)

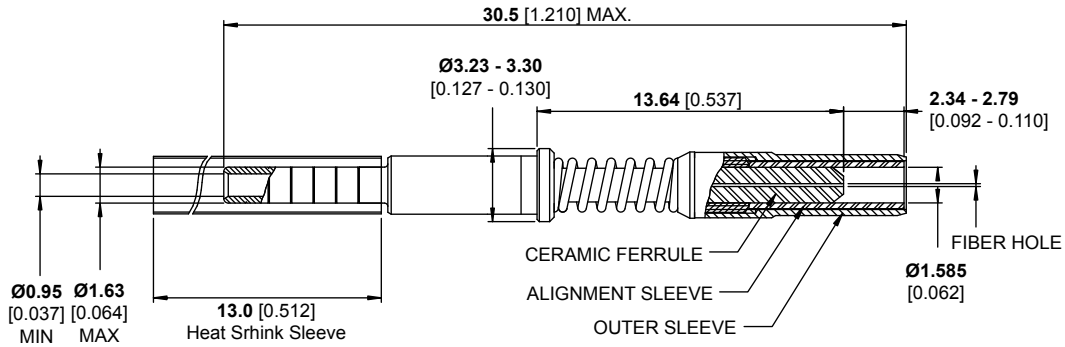

Pin (457463)

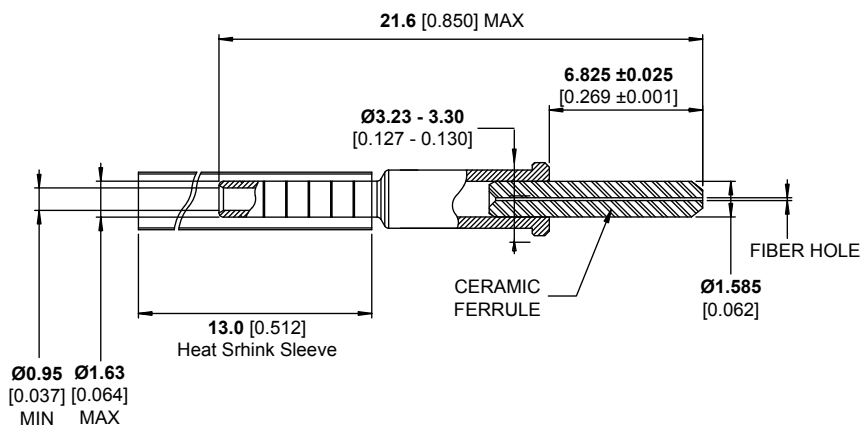

Part Numbering

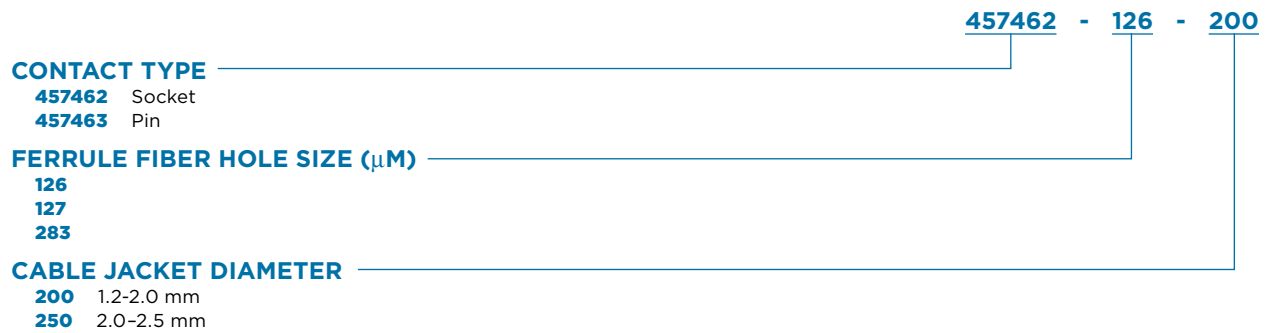



- EASY TO USE**
- Screen termination by stainless steel band
 - Sealing and strain relief of backshell by heat shrink boot
- VERSATILE**
- Versions for all 38999 series
 - Straight, 45°, and 90° profiles
 - Optional pigtail termination slots

POLAMCO BT Series Banding Backshells



BT Series backshells terminate the shield with a stainless steel band strap. Additional strain relief can be obtained with a heat-shrink boot.

Part Numbering System

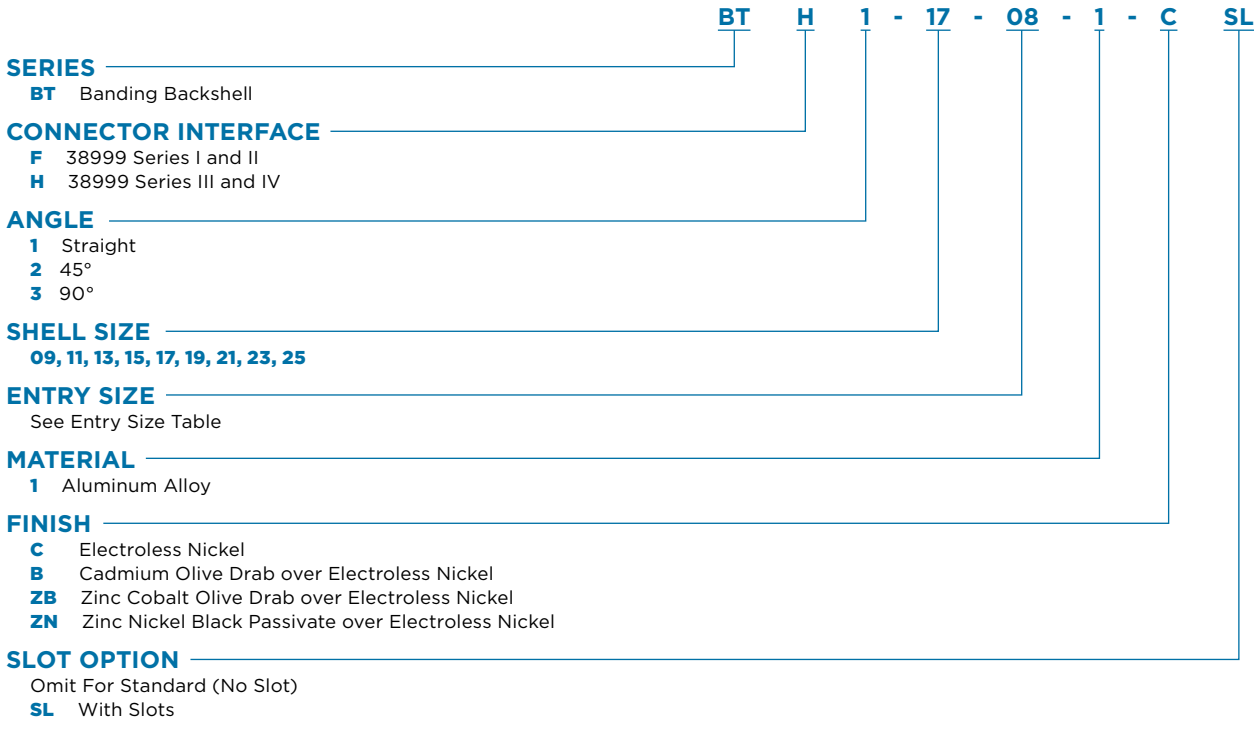



POLAMCO BT Series Banding Backshells

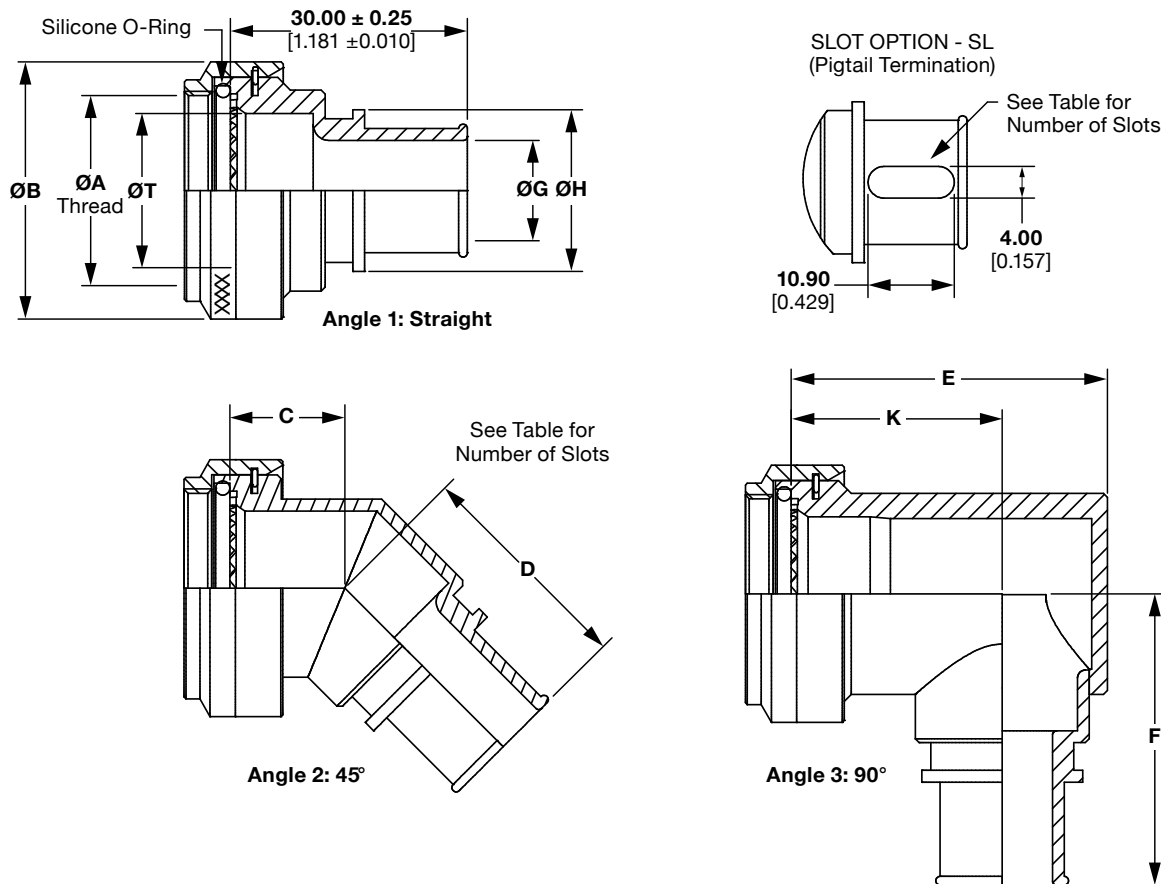

BTF Series for 38999 Series I (Consult TE for Series II)

Shell Size	A Thread BTH (BTF)	ØB Max. BTF	ØT Min.	C Max.	D Max.	E Max.	F Max.	K ±0.5 (0.020)
09	7/16-28	18.3 0.720	6.7 0.264	13.1 0.516	25.7 1.012	25.7 1.012	30.5 1.201	17.5 0.689
11	9/16-24	21.5 0.846	10.2 0.402	13.9 0.547	26.9 1.059	26.7 1.051	32.2 1.268	17.5 0.689
13	11/16-24	24.5 0.965	13.5 0.531	14.5 0.571	27.3 1.075	31.2 1.228	33.7 1.327	20.0 0.787
15	13/16-20	27.8 1.094	16.2 0.638	15.5 0.610	28.2 1.110	37.2 1.465	35.2 1.386	24.5 0.965
17	15/16-20	30.8 1.213	19.4 0.764	16.1 0.634	29.0 1.142	40.2 1.583	36.9 1.453	26.7 1.051
19	1-1/16-18	34.1 1.343	21.8 0.858	16.8 0.661	29.3 1.154	44.7 1.760	38.5 1.516	27.0 1.063
21	1-3/16-18	37.3 1.469	25.1 0.988	17.1 0.673	30.1 1.185	49.2 1.937	40.1 1.579	30.5 1.201
23	1-5/16-18	40.5 1.594	28.2 1.110	17.7 0.697	30.5 1.201	51.7 2.035	41.6 1.638	31.5 1.240
25	1-7/16-18	43.7 1.720	31.4 1.236	18.4 0.724	31.4 1.236	53.2 2.094	43.1 1.697	28.5 1.122

Millimeters Inches



POLAMCO BT Series Banding Backshells

BTH Series for 38999 Series III and IV

Shell Size	A Thread	ØB Max.	ØT Min.	C Max.	D Max.	E Max.	F Max.	K ±0.5 (0.020)
09	M12 x 1.0	18.0 0.709	6.7 0.264	13.1 0.516	25.7 1.012	25.7 1.012	30.5 1.201	17.5 0.689
11	M15 x 1.0	21.0 0.827	10.2 0.402	13.9 0.547	26.9 1.059	26.7 1.051	32.2 1.268	17.5 0.689
13	M18 x 1.0	24.5 0.965	13.5 0.531	14.5 0.571	27.3 1.075	31.2 1.228	33.7 1.327	20.0 0.787
15	M22 x 1.0	29.0 1.142	16.2 0.638	15.5 0.610	28.2 1.110	37.2 1.465	35.2 1.386	24.5 0.965
17	M25 x 1.0	32.5 1.280	19.4 0.764	16.1 0.634	29.0 1.142	40.2 1.583	36.9 1.453	26.7 1.051
19	M28 x 1.0	35.5 1.398	21.8 0.858	16.8 0.661	29.3 1.154	44.7 1.760	38.5 1.516	27.0 1.063
21	M31 x 1.0	37.0 1.457	25.1 0.988	17.1 0.673	30.1 1.185	49.2 1.937	40.1 1.579	30.5 1.201
23	M34 x 1.0	40.0 1.575	28.2 1.110	17.7 0.697	30.5 1.201	51.7 2.035	41.6 1.638	31.5 1.240
25	M37 x 1.0	43.5 1.713	31.4 1.236	18.4 0.724	31.4 1.236	53.2 2.094	43.1 1.697	28.5 1.122

Millimeters Inches

Entry Size Dimensions

Entry Size	ØG Min.	ØH Max.	No. Of Optional Slots
03	4.7 0.185	13.9 0.547	1
04	6.3 0.248	13.9 0.547	1
05	7.9 0.311	15.5 0.610	1
06	9.5 0.374	17.2 0.677	2
07	11.1 0.437	18.7 0.736	2
08	12.7 0.500	20.3 0.799	2
09	14.2 0.559	21.9 0.862	2
10	15.8 0.622	23.5 0.925	2
11	17.4 0.685	25.1 0.988	2
12	19.0 0.748	26.7 1.051	2
13	20.6 0.811	28.3 1.114	2

Millimeters Inches

Entry Size	ØG Min.	ØH Max.	No. Of Optional Slots
14	22.2 0.874	29.9 1.177	4
15	23.8 0.937	31.5 1.240	4
16	25.4 1.000	33.1 1.303	4
17	27.0 1.063	34.7 1.366	4
18	28.6 1.126	36.3 1.429	4
19	30.2 1.189	37.9 1.492	4
20	31.8 1.252	39.5 1.555	4
21	33.3 1.311	41.1 1.618	4
22	35.0 1.378	42.7 1.681	4
23	36.5 1.437	44.3 1.744	4
24	38.1 1.500	45.9 1.807	4

Millimeters Inches



EASY TO USE

- Individual screen termination using castellated cone
- No application tooling required for termination or re-work
- Alternate angles and lengths on request

RELIABLE

- Sealing and strain relief of backshell by heat shrink boot
- Solid machined construction for reliable strength and performance
- Cable clamp option available for additional mechanical strain relief

VERSATILE

- Plain nut version available
- Cone clamp feature may be re-used
- Straight, 45 degree, and 90 degree standard
- Aluminum, bronze, and stainless steel

POLAMCO 64 Series Cone Clamp Adapters



The 64 Series adapters terminate individual shields with a castellated cone to compress the braid.

Part Numbering System

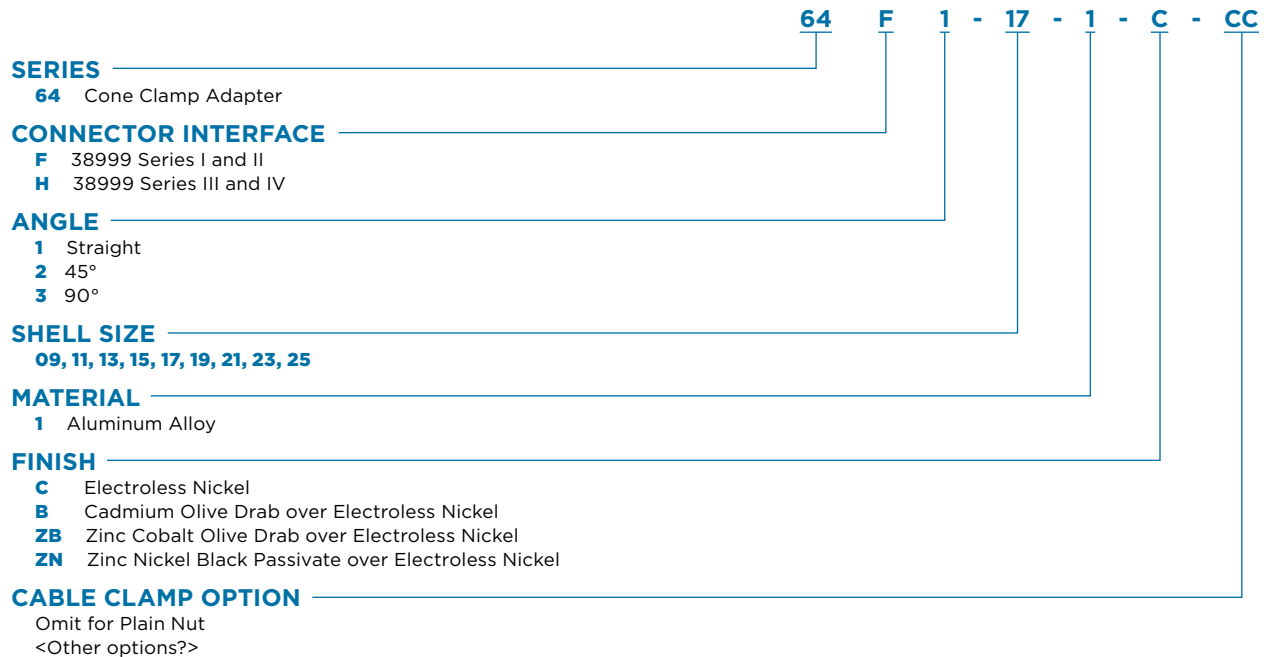



POLAMCO 64 Series Cone Clamp Adapters

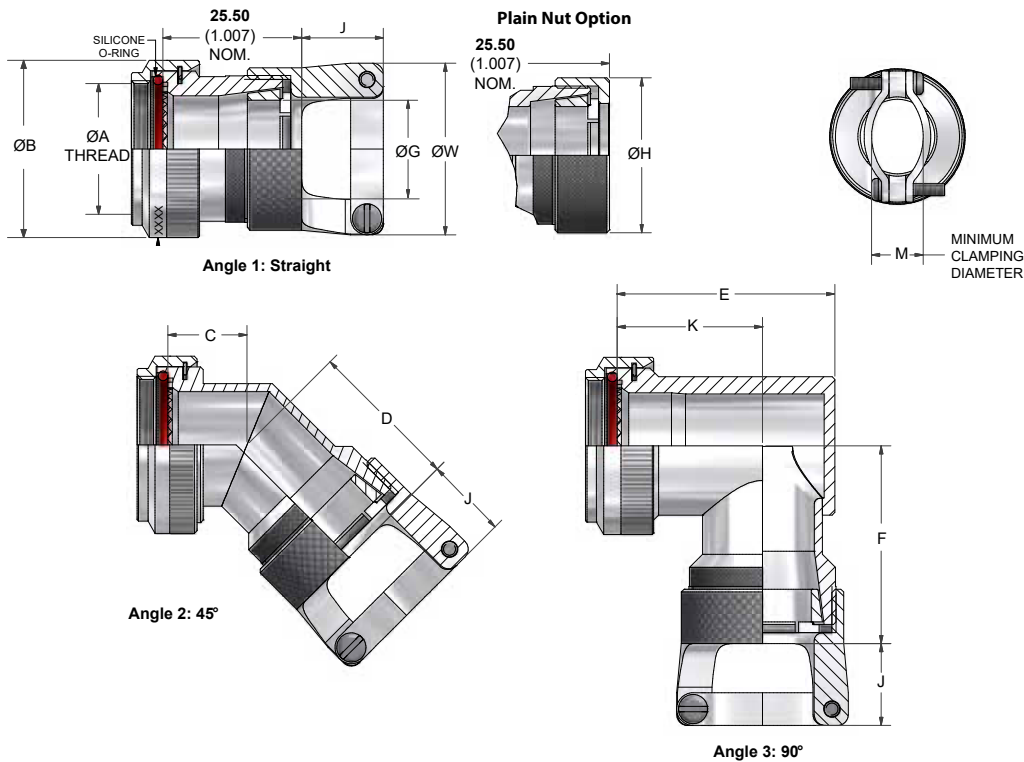

64F Series for 38999 Series I Connectors (Consult TE for Series II)

Shell Size	A Thread (UNEF)	ØB Max.	C ±0.5 (0.020)	D Max.	E Max.	F Max.	ØG Min.	ØW Max.	ØH Max.	J Max.	K ±0.5 (0.020)	M ±0.5 (0.020)
09	7/16-28	18.0 0.709	16.4 0.646	24.6 0.969	22.7 0.894	30.1 1.185	6.6 0.260	20.7 0.815	16.0 0.630	15.2 0.598	15.0 0.591	7.8 0.307
11	9/16-24	21.0 0.827	17.2 0.677	25.4 1.000	26.2 1.031	31.9 1.256	9.3 0.366	23.8 0.937	19.0 0.748	15.2 0.598	17.0 0.669	8.6 0.339
13	11/16-24	24.5 0.965	17.6 0.693	26.3 1.035	29.2 1.150	33.4 1.315	12.6 0.496	27.0 1.063	22.0 0.866	15.2 0.598	18.0 0.709	10.2 0.402
15	13/16-20	27.8 1.094	18.5 0.728	26.7 1.051	32.2 1.268	34.9 1.374	14.6 0.575	28.6 1.126	25.4 1.000	15.2 0.598	20.0 0.787	10.4 0.409
17	15/16-20	30.8 1.213	19.2 0.756	27.5 1.083	35.7 1.406	36.6 1.441	17.7 0.697	31.8 1.252	28.5 1.122	15.2 0.598	21.5 0.846	12.4 0.488
19	1-1/16-18	34.1 1.343	19.6 0.772	27.8 1.094	39.7 1.563	38.2 1.504	19.8 0.780	35.0 1.378	32.0 1.260	18.2 0.717	23.0 0.906	15.4 0.606
21	1-3/16-18	37.3 1.469	20.4 0.803	28.6 1.126	42.2 1.661	39.8 1.567	23.0 0.906	38.1 1.500	35.0 1.378	18.2 0.717	25.0 0.984	17.3 0.681
23	1-5/16-18	41.0 1.614	20.8 0.819	29.5 1.161	45.2 1.780	41.3 1.626	26.2 1.031	39.7 1.563	38.0 1.496	18.2 0.717	26.0 1.024	18.8 0.740
25	117/16-18	43.7 1.720	21.7 0.854	29.9 1.177	48.2 1.898	42.8 1.685	29.1 1.146	44.5 1.752	41.0 1.614	18.2 0.717	28.0 1.102	22.4 0.882

Millimeters Inches



POLAMCO 64 Series Cone Clamp Adapters

64H Series for 38999 Series III and IV

Shell Size	A Thread	ØB Max.	C ±0.5 (0.020)	D Max.	E Max.	F Max.	ØG Min.	ØW Max.	ØH Max.	J Max.	K ±0.5 (0.020)	M ±0.5 (0.020)
09	M12 x 1.0	18.0 0.709	13.1 0.516	24.6 0.969	25.7 1.012	30.1 1.185	6.6 0.260	20.7 0.815	16.0 0.630	15.2 0.598	17.5 0.689	7.8 0.307
11	M15 x 1.0	21.0 0.827	13.9 0.547	25.4 1.000	26.7 1.051	31.9 1.256	9.3 0.366	23.8 0.937	19.0 0.748	15.2 0.598	17.5 0.689	8.6 0.339
13	M18 x 1.0	24.5 0.965	14.5 0.571	26.3 1.035	31.2 1.228	33.4 1.315	12.6 0.496	27.0 1.063	22.0 0.866	15.2 0.598	20.0 0.787	10.2 0.402
15	M22 x 1.0	29.0 1.142	15.5 0.610	26.7 1.051	37.2 1.465	34.9 1.374	14.6 0.575	28.6 1.126	26.5 1.043	15.2 0.598	24.5 0.965	10.4 0.409
17	M25 x 1.0	32.5 1.280	16.1 0.634	27.5 1.083	40.2 1.583	36.6 1.441	17.7 0.697	31.8 1.252	29.8 1.173	15.2 0.598	26.7 1.051	12.4 0.488
19	M28 x 1.0	35.5 1.398	16.8 0.661	27.8 1.094	44.7 1.760	38.2 1.504	19.8 0.780	35.0 1.378	33.0 1.299	18.2 0.717	27.0 1.063	15.4 0.606
21	M31 x 1.0	37.0 1.457	17.1 0.673	28.6 1.126	49.2 1.937	39.8 1.567	23.0 0.906	38.1 1.500	35.0 1.378	18.2 0.717	30.5 1.201	17.3 0.681
23	M34 x 1.0	40.0 1.575	17.7 0.697	29.5 1.161	51.7 2.035	41.3 1.626	26.2 1.031	39.7 1.563	38.0 1.496	18.2 0.717	31.5 1.240	18.8 0.740
25	M37 x 1.0	43.5 1.713	18.4 0.724	29.9 1.177	53.2 2.094	42.8 1.685	29.1 1.146	44.5 1.752	41.0 1.614	18.2 0.717	28.5 1.122	22.4 0.882

Millimeters Inches



VERSATILE

- Interfaces with 38999 Series I, II, III and IV connectors
- Available in straight, 45°, and 90° angle mounting configurations
- Variety of finishes available

LIGHTWEIGHT

- Aluminum alloy saves weight
- Low-profile shield termination

HIGH RELIABILITY

- Magna-form memory ring adapter technology
- Optional pre-terminated braid sock

POLAMCO 70 Series Memory Ring Adapters



The 70 Series adapters help provide a high-reliability, low profile shield termination using magna-form memory ring technology. The adapters are available with an optional pre-terminated braid sock.

Part Numbering System

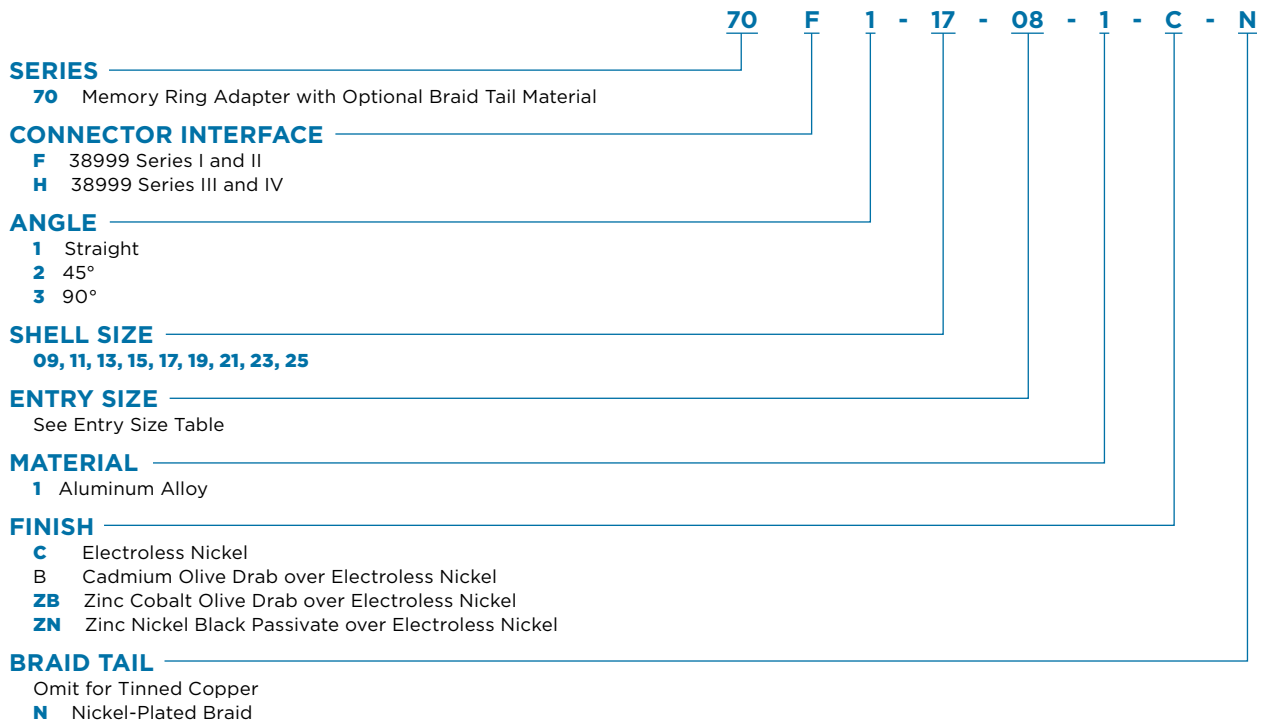



POLAMCO 70 Series Memory Ring Adapters

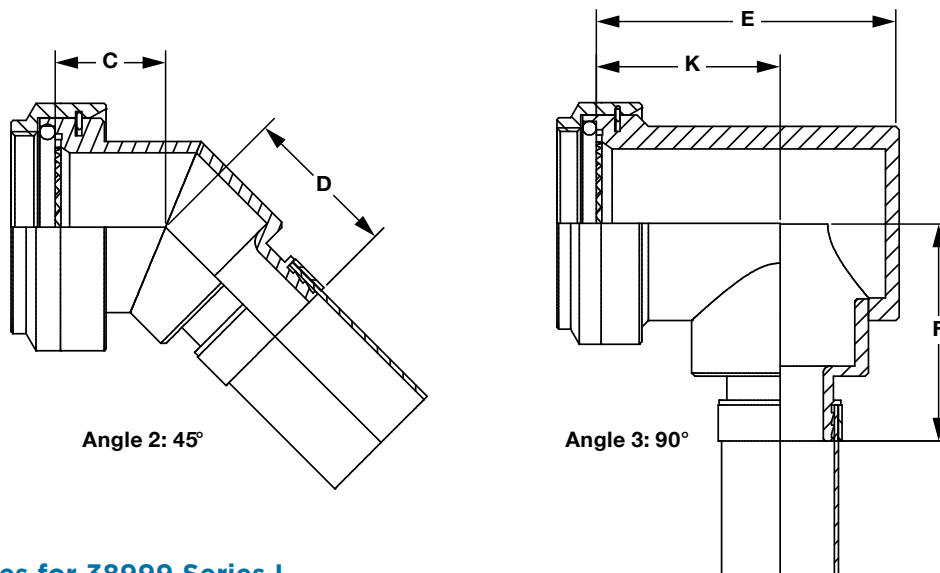
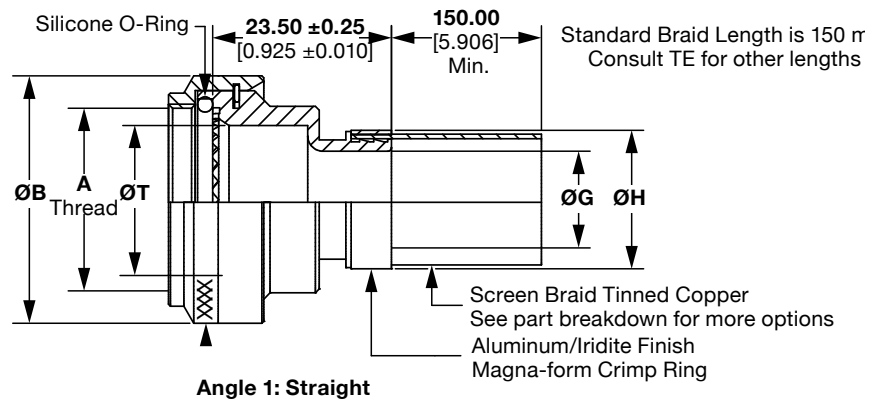

70F Series for 38999 Series I (Consult TE for Series II)

Shell Size	A Thread (UNEF)	ØB Max.	ØT Min.	C Max.	D ±0.5 (0.020)	E Max.	F Max.	K ±0.5 (0.020)
09	7/16-28	18.0 0.709	6.8 0.268	16.4 0.646	17.1 0.673	22.7 0.894	24.0 0.945	15.0 0.591
11	9/16-24	21.0 0.827	10.2 0.402	17.2 0.677	18.2 0.717	26.2 1.031	25.7 1.012	17.0 0.669
13	11/16-24	24.5 0.965	13.1 0.516	17.6 0.693	18.6 0.732	29.2 1.150	27.2 1.071	18.0 0.709
15	13/16-20	27.8 1.094	16.2 0.638	18.5 0.728	19.5 0.768	32.2 1.268	28.7 1.130	20.0 0.787
17	15/16-20	30.8 1.213	19.3 0.760	20.2 0.795	20.3 0.799	35.7 1.406	30.4 1.197	21.5 0.846
19	1-1/16-18	34.1 1.343	22.3 0.878	19.6 0.772	20.8 0.819	39.7 1.563	32.0 1.260	23.0 0.906
21	1-3/16-18	37.3 1.469	25.8 1.016	20.4 0.803	21.7 0.854	42.2 1.661	33.6 1.323	25.0 0.984
23	1-5/16-18	41.0 1.614	28.3 1.114	20.8 0.819	22.0 0.866	45.2 1.780	35.1 1.382	26.0 1.024
25	1-7/16-18	43.7 1.720	31.5 1.240	21.7 0.854	22.9 0.902	48.2 1.898	36.6 1.441	28.0 1.102

Millimeters Inches



POLAMCO 70 Series Memory Ring Adapters

70H Series for 38999 Series III and IV

Shell Size	A Thread	ØB Max.	ØT Min.	C Max.	D ±0.5 (0.020)	E Max.	F Max.	K ±0.5 (0.020)
09	M12 x 1.0	18.0 0.709	6.7 0.264	13.1 0.516	17.1 0.673	25.7 1.012	24.0 0.945	17.5 0.689
11	M15 x 1.0	21.0 0.827	10.2 0.402	13.9 0.547	18.2 0.717	26.7 1.051	25.7 1.012	17.5 0.689
13	M18 x 1.0	24.5 0.965	13.5 0.531	14.5 0.571	18.6 0.732	31.2 1.228	27.2 1.071	20.0 0.787
15	M22 x 1.0	29.0 1.142	16.2 0.638	15.5 0.610	19.5 0.768	37.2 1.465	28.7 1.130	24.5 0.965
17	M25 x 1.0	32.5 1.280	19.4 0.764	16.1 0.634	20.3 0.799	40.2 1.583	30.4 1.197	26.7 1.051
19	M28 x 1.0	35.5 1.398	21.8 0.858	16.8 0.661	20.8 0.819	44.7 1.760	32.0 1.260	27.0 1.063
21	M31 x 1.0	37.0 1.457	25.1 0.988	17.1 0.673	21.7 0.854	49.2 1.937	33.6 1.323	30.5 1.201
23	M34 x 1.0	40.0 1.575	28.2 1.110	17.7 0.697	22.0 0.866	51.7 2.035	35.1 1.382	31.5 1.240
25	M37 x 1.0	43.5 1.713	31.4 1.236	18.4 0.724	22.9 0.902	53.2 2.094	36.6 1.441	28.5 1.122

Millimeters Inches

Entry Size Dimensions

Entry Size	ØG Min.	ØH Max.	No. Of Optional Slots
03	4.7 0.185	13.9 0.547	1
04	6.3 0.248	13.9 0.547	1
05	7.9 0.311	15.5 0.610	1
06	9.5 0.374	17.2 0.677	2
07	11.1 0.437	18.7 0.736	2
08	12.7 0.500	20.3 0.799	2
09	14.2 0.559	21.9 0.862	2
10	15.8 0.622	23.5 0.925	2
11	17.4 0.685	25.1 0.988	2
12	19.0 0.748	26.7 1.051	2
13	20.6 0.811	28.3 1.114	2

Millimeters Inches

Entry Size	ØG Min.	ØH Max.	No. Of Optional Slots
14	22.2 0.874	29.9 1.177	4
15	23.8 0.937	31.5 1.240	4
16	25.4 1.000	33.1 1.303	4
17	27.0 1.063	34.7 1.366	4
18	28.6 1.126	36.3 1.429	4
19	30.2 1.189	37.9 1.492	4
20	31.8 1.252	39.5 1.555	4
21	33.3 1.311	41.1 1.618	4
22	35.0 1.378	42.7 1.681	4
23	36.5 1.437	44.3 1.744	4
24	38.1 1.500	45.9 1.807	4

Millimeters Inches



VERSATILE

- Interfaces with 38999 Series I, II, III and IV connectors
- Available in straight, 45°, and 90° angle mounting configurations
- Variety of finishes available

LIGHTWEIGHT

- Aluminum alloy saves weight
- Low-profile shield termination

HIGH RELIABILITY

- Constant force stainless steel spring enables fast, reliable termination

EASY TO USE

- Tool-free screen termination
- Variety of shell sizes available from stock
- Heat-shrink boot option available for strain relief and cable sealing

POLAMCO 91 Series Spring Adapters



The 91 Series adapters use a constant-force spring to help provide a fast, reliable shield termination without tools.

Part Numbering System

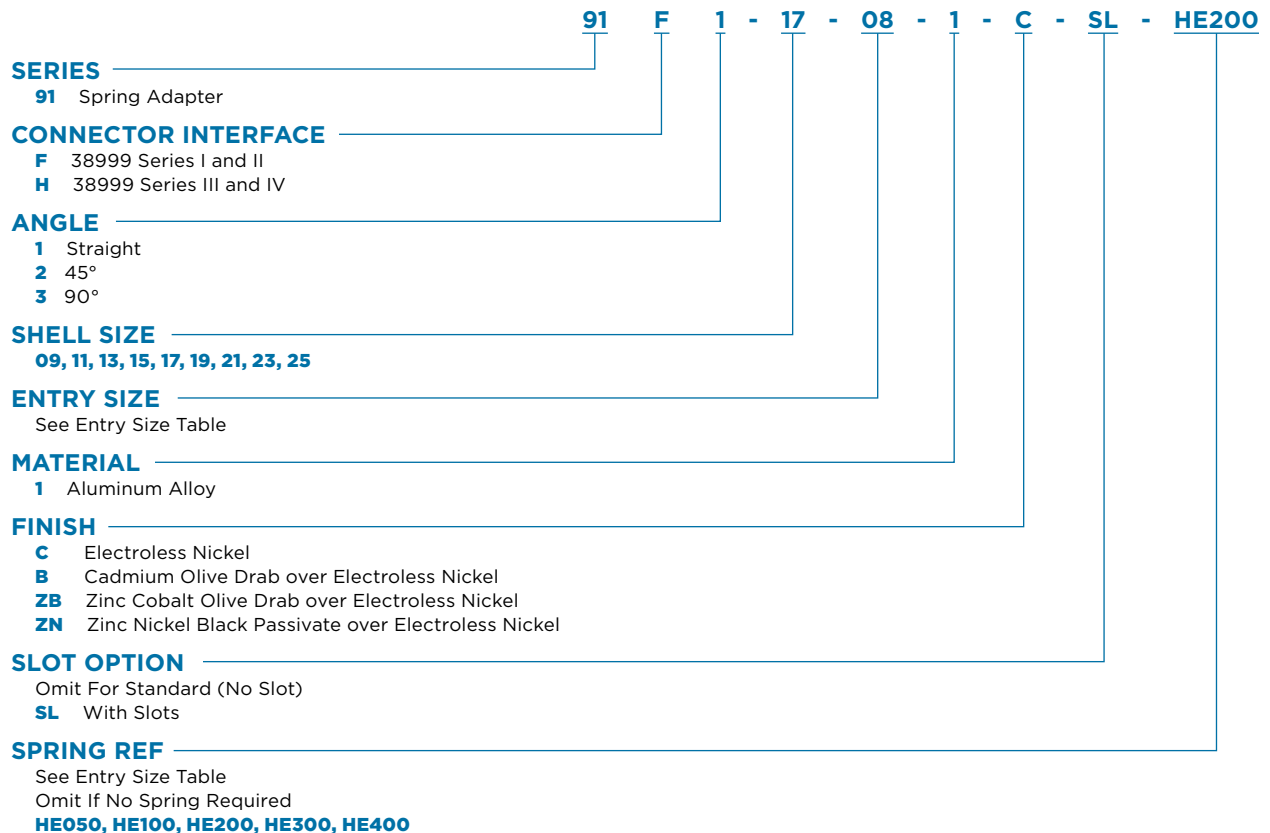



POLAMCO 91 Series Spring Adapters

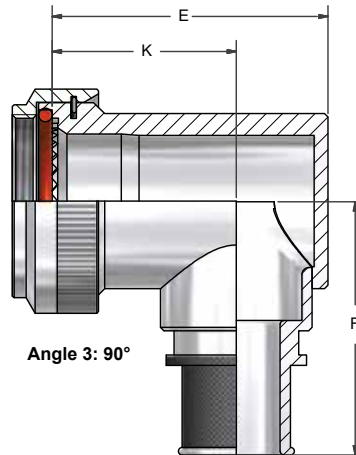
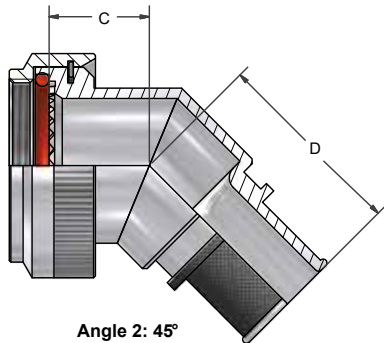
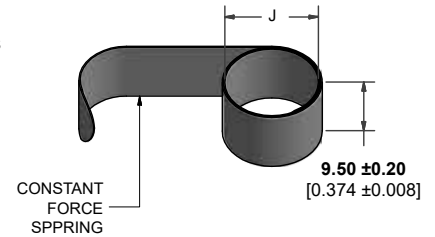
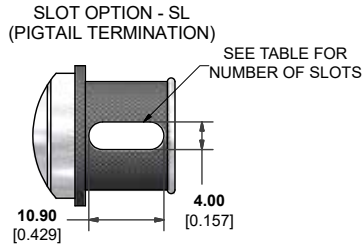
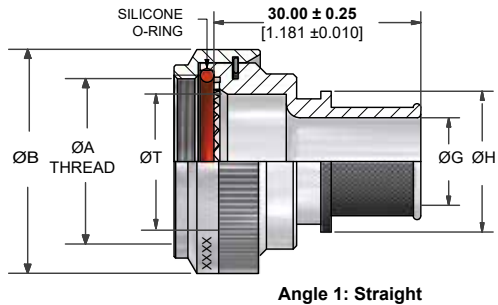

91F Series for 38999 Series I
(Consult TE for Series II)

Shell Size	A Thread (UNEF)	ØB Max.	ØT Min.	C ±0.5 (0.020)	D Max.	E Max.	F Max.	K ±0.5 (0.020)
09	7/16-28	18.0 0.709	6.8 0.268	16.4 0.646	25.7 1.012	22.7 0.894	30.5 1.201	15.0 0.591
11	9/16-24	21.0 0.827	10.2 0.402	17.2 0.677	26.9 1.059	26.2 1.031	32.2 1.268	17.0 0.669
13	11/16-24	24.5 0.965	13.1 0.516	17.6 0.693	27.3 1.075	29.2 1.150	33.7 1.327	18.0 0.709
15	13/16-20	27.8 1.094	16.2 0.638	18.5 0.728	28.2 1.110	32.2 1.268	35.2 1.386	20.0 0.787
17	15/16-20	30.8 1.213	19.3 0.760	19.2 0.756	29.0 1.142	35.7 1.406	36.9 1.453	21.5 0.846
19	1-1/16-18	34.1 1.343	22.3 0.878	19.6 0.772	29.3 1.154	39.7 1.563	38.5 1.516	23.0 0.906
21	1-3/16-18	37.3 1.469	25.8 1.016	20.4 0.803	30.1 1.185	42.2 1.661	41.1 1.618	25.0 0.984
23	1-5/16-18	41.0 1.614	28.3 1.114	20.8 0.819	30.5 1.201	45.2 1.780	41.6 1.638	26.0 1.024
25	1-7/16-18	43.7 1.720	31.5 1.240	21.7 0.854	31.4 1.236	48.2 1.898	43.1 1.697	28.0 1.102

Millimeters Inches



POLAMCO 91 Series Spring Adapters

91H Series for 38999 Series III and IV

Shell Size	A Thread	ØB Max.	ØT Min.	C ±0.5 (0.020)	D Max.	E Max.	F Max.	K ±0.5 (0.020)
09	M12 x 1.0	18.0 0.709	6.7 0.264	13.1 0.516	25.7 1.012	25.7 1.012	30.5 1.201	17.5 0.689
11	M15 x 1.0	21.0 0.827	10.2 0.402	13.9 0.547	26.9 1.059	26.7 1.051	32.2 1.268	17.5 0.689
13	M18 x 1.0	24.5 0.965	13.5 0.531	14.5 0.571	27.3 1.075	31.2 1.228	33.7 1.327	20.0 0.787
15	M22 x 1.0	29.0 1.142	16.2 0.638	15.5 0.610	28.2 1.110	37.2 1.465	35.2 1.386	24.5 0.965
17	M25 x 1.0	32.5 1.280	19.4 0.764	16.1 0.634	29.0 1.142	40.2 1.583	36.9 1.453	26.7 1.051
19	M28 x 1.0	35.5 1.398	21.8 0.858	16.8 0.661	29.3 1.154	44.7 1.760	38.5 1.516	27.0 1.063
21	M31 x 1.0	37.0 1.457	25.1 0.988	17.1 0.673	30.1 1.185	49.2 1.937	40.1 1.579	30.5 1.201
23	M34 x 1.0	40.0 1.575	28.2 1.110	17.7 0.697	30.5 1.201	51.7 2.035	41.6 1.638	31.5 1.240
25	M37 x 1.0	43.5 1.713	31.4 1.236	18.4 0.724	31.4 1.236	53.2 2.094	43.1 1.697	28.5 1.122

Millimeters Inches

Entry Size Dimensions

Entry Size	ØG Min.	ØH Max.	No. Of Optional Slots	Spring Ref	J Max. (Unconstrained)	Entry Size	ØG Min.	ØH Max.	No. Of Optional Slots	Spring Ref	J Max. (Unconstrained)		
03	4.7 0.185	13.9 0.547	1	HE050	7.5 0.295	12	19.0 0.748	26.7 1.051	2	HE300	17.9 0.705		
04	6.3 0.248	13.9 0.547	1			13	20.6 0.811	28.3 1.114	2				
05	7.9 0.311	15.5 0.610	1			14	22.2 0.874	29.9 1.177	4				
06	9.5 0.374	17.2 0.677	2	HE100	9.1 0.358	15	23.8 0.937	31.5 1.240	4				
07	11.1 0.437	18.7 0.736	2			16	25.4 1.000	33.1 1.303	4				
08	12.7 0.500	20.3 0.799	2	HE200	12.8 0.504	17	27.0 1.063	34.7 1.366	4				
09	14.2 0.559	21.9 0.862	2			18	28.6 1.126	36.3 1.429	4				
10	15.8 0.622	23.5 0.925	2			19	30.2 1.189	37.9 1.492	4				
11	17.4 0.685	25.1 0.988	2			20	31.8 1.252	39.5 1.555	4			HE400	21.8 0.858
						21	33.3 1.311	41.1 1.618	4				
22	35.0 1.378	42.7 1.681	4	23	36.5 1.437	44.3 1.744	4						
24	38.1 1.500	45.9 1.807	4										

Millimeters Inches



SAVE WEIGHT

- Lightweight open-frame cable clamp
- Backshell machined from solid aluminum to help maximize strength and reliability

VERSATILE

- Interfaces with 38999 Series I, II, III and IV connectors
- Available in straight and 90° angle mounting configurations
- Variety of finishes available

POLAMCO 96 Series Strain Relief Adapters



The 96 Series adapters provide strain relief in an open-frame cable clamp. The backshell is machined from solid aluminum alloy to support strength, reliability, and low weight.

Part Numbering System

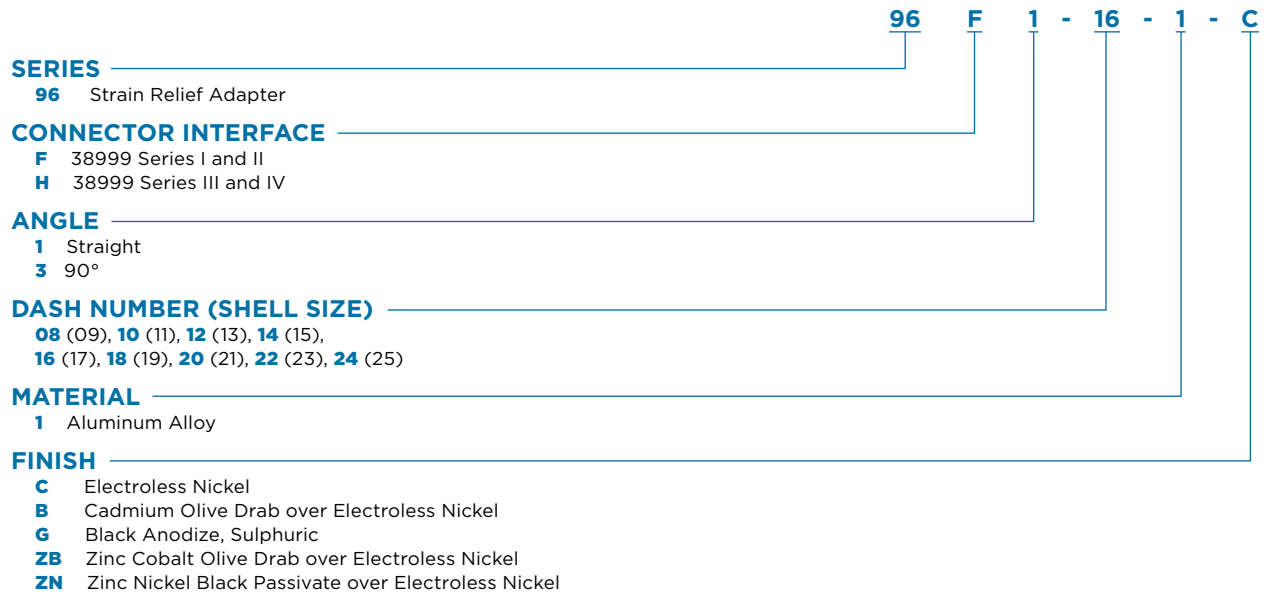



POLAMCO 96 Series Strain Relief Adapters

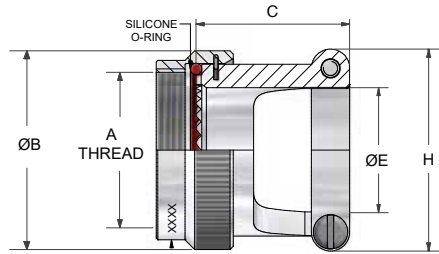

Angle 1: Straight

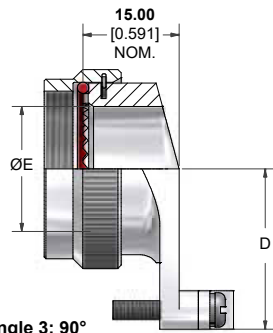

Angle 3: 90°

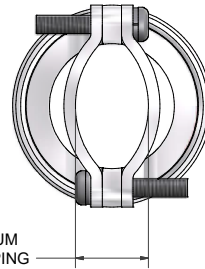

K
MINIMUM
CLAMPING
DIAMETER



M
MINIMUM
CLAMPING
DIAMETER

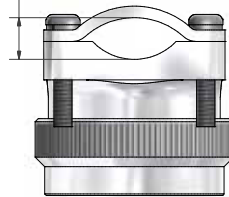



POLAMCO 96 Series Strain Relief Adapters

96F Series for 38999 Series I and II

Dash No.	Shell Size: Series I (Series II)	A Thread (UNEF)	ØB Max.	C Max.	D Max.	ØE Min.	H Max.	J Max.	K ±0.5 (0.020) Clamping Diameter	M ±0.5 (0.020) Clamping Diameter
08	09 (08)	7/16-28	18.3 0.720	21.5 0.846	18.8 0.740	6.7 0.264	19.0 0.748	19.0 0.748	5.7 0.224	4.7 0.185
10	11 (10)	9/16-24	21.5 0.846	21.5 0.846	21.1 0.831	10.1 0.398	22.2 0.874	22.2 0.874	6.9 0.272	5.3 0.209
12	13 (12)	11/16-24	24.5 0.965	23.5 0.925	23.1 0.909	13.0 0.512	25.2 0.992	25.2 0.992	8.5 0.335	5.8 0.228
14	15 (14)	13/16-20	27.8 1.094	23.5 0.925	25.5 1.004	16.1 0.634	28.5 1.122	28.5 1.122	10.4 0.409	7.7 0.303
16	17 (16)	15/16-20	30.8 1.213	24.5 0.965	29.1 1.146	19.3 0.760	31.7 1.248	31.7 1.248	11.4 0.449	8.2 0.323
18	19 (18)	1-1/16-18	34.1 1.343	27.5 1.083	35.1 1.382	21.8 0.858	34.9 1.374	34.9 1.374	14.9 0.587	9.7 0.382
20	21 (20)	1-3/16-18	37.3 1.469	34.5 1.358	37.7 1.484	25.2 0.992	38.0 1.496	38.0 1.496	16.8 0.661	10.7 0.421
22	23 (22)	1-5/16-18	40.5 1.594	34.5 1.358	39.8 1.567	28.1 1.106	42.8 1.685	41.2 1.622	23.9 0.941	11.8 0.465
24	25 (24)	1-7/16-18	43.7 1.720	34.5 1.358	42.0 1.654	31.3 1.232	46.0 1.811	44.4 1.740	22.8 0.898	12.7 0.500

Millimeters Inches

96H Series for 38999 Series III and IV

Shell Size	A Thread	ØB Max.	C Max.	D Max.	ØE Min.	H Max.	J Max.	K ±0.5 Clamping Diameter	M ±0.5 Clamping Diameter
09	M12 x 1.0	18.0 0.709	21.5 0.846	20.4 0.803	6.7 0.264	19.0 0.748	20.6 0.811	5.7 0.224	5.2 0.205
11	M15 x 1.0	21.0 0.827	21.5 0.846	21.4 0.843	10.1 0.398	22.2 0.874	22.2 0.874	6.9 0.272	5.2 0.205
13	M18 x 1.0	24.5 0.965	23.5 0.846	22.4 0.882	13.0 0.512	25.2 0.992	23.7 0.933	8.5 0.335	5.6 0.220
15	M22 x 1.0	27.5 1.083	23.5 0.925	23.4 0.921	16.1 0.634	28.5 1.122	26.9 1.059	10.4 0.409	6.4 0.252
17	M25 x 1.0	31.0 1.220	24.5 0.925	25.4 1.000	19.3 0.760	31.7 1.248	28.5 1.122	11.4 0.449	6.5 0.256
19	M28 x 1.0	34.0 1.339	27.5 0.965	27.9 1.098	21.8 0.858	34.9 1.374	31.7 1.248	14.9 0.587	7.0 0.276
21	M31 x 1.0	37.0 1.457	34.5 1.083	31.9 1.256	25.2 0.992	38.0 1.496	34.9 1.374	16.8 0.661	8.5 0.335
23	M34 x 1.0	40.0 1.575	37.5 1.358	35.4 1.394	28.1 1.106	42.8 1.685	38.0 1.496	23.9 0.941	9.4 0.370
25	M37 x 1.0	43.5 1.713	37.5 1.476	36.4 1.433	31.3 1.232	46.0 1.811	38.0 1.496	22.8 0.898	9.4 0.370

Millimeters Inches



HIGH PERFORMANCE

- Profile of backshell specifically designed to help optimize performance with heat shrink boot
- Optional heat-shrink boot available to help provide strain relief
- Alternative to M85049/62

VERSATILE

- Interfaces with 38999 Series I, II, III and IV connectors
- Available in straight, 45°, and 90° angle mounting configurations
- Variety of finishes available
- Standard range - many sizes available from stock

POLAMCO 97 Series Heat-Shrink Boot Adapters



The 97 Series adapters are designed to help provide high performance when used with an optional heat-shrink boot to provide strain relief. Many shell sizes are available from stock, providing an easy alternative to M85049/62 backshells.

Part Numbering System

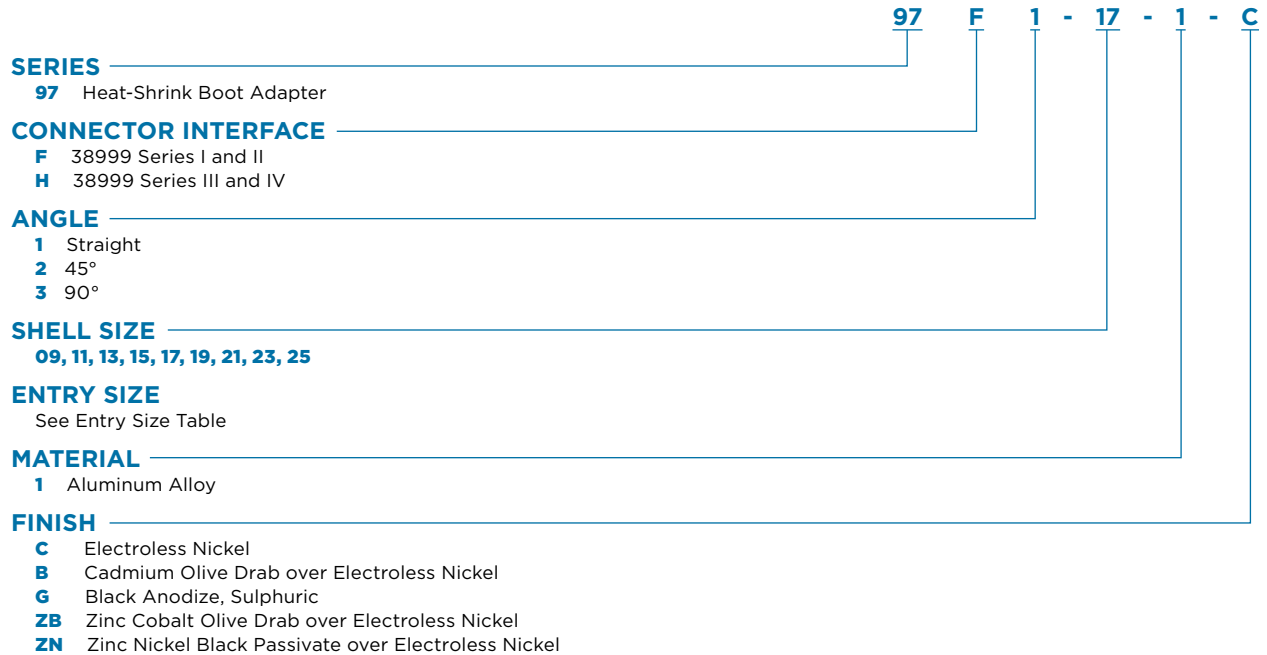



POLAMCO 97 Series Heat-Shrink Boot Adapters

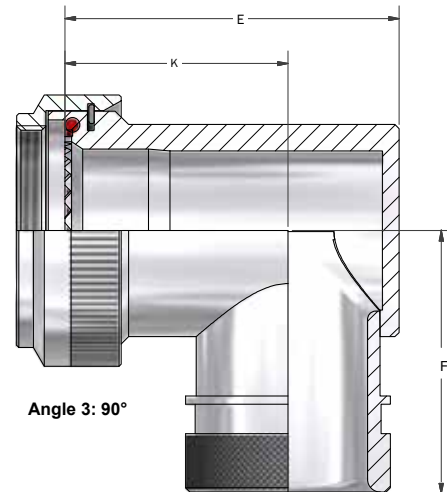
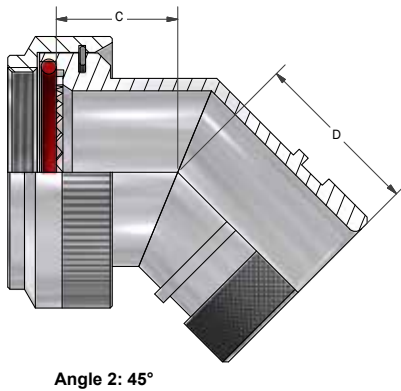
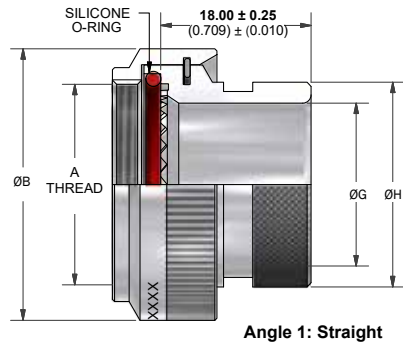
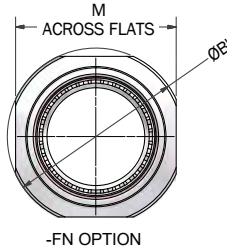

97F Series for 38999 Series I (Consult TE for Series II)

Shell Size	A Thread	ØB Max.	ØG Max.	ØH Max.	C ±0.5	D Max.	E Max.	F Max.	K ±0.5 (0.020)	Recommended Boot Size
09	7/16-28	18.0 0.709	6.8 0.268	13.5 0.531	16.4 0.646	17.6 0.693	22.7 0.894	25.5 1.004	15.0 0.591	202K121
11	9/16-24	21.0 0.827	10.2 0.402	15.4 0.606	17.2 0.677	18.4 0.724	26.2 1.031	27.3 1.075	17.0 0.669	202K121
13	11/16-24	24.5 0.965	13.1 0.516	19.7 0.776	17.6 0.693	19.3 0.760	29.2 1.150	28.7 1.130	18.0 0.709	202K142
15	13/16-20	27.8 1.094	16.2 0.638	21.3 0.839	18.5 0.728	19.6 0.772	32.2 1.268	30.2 1.189	20.0 0.787	202K142
17	15/16-20	30.8 1.213	19.3 0.760	24.5 0.965	19.2 0.756	20.4 0.803	35.7 1.406	31.9 1.256	21.5 0.846	202K153
19	1-1/16-18	34.1 1.343	22.3 0.878	26.5 1.043	19.6 0.772	20.8 0.819	39.7 1.563	33.5 1.319	23.0 0.906	202K153
21	1-3/16-18	37.3 1.469	25.8 1.016	31.0 1.220	20.4 0.803	21.6 0.850	42.2 1.661	35.1 1.382	25.0 0.984	202K153
23	1-5/16-18	41.0 1.614	28.3 1.114	34.4 1.354	20.8 0.819	22.5 0.886	45.2 1.780	36.7 1.445	26.0 1.024	202K163
25	1-7/16-18	43.7 1.720	31.5 1.240	36.6 1.441	21.7 0.854	22.9 0.902	48.2 1.898	38.1 1.500	28.0 1.102	202K163

Millimeters Inches



POLAMCO 97 Series Heat-Shrink Boot Adapters

97H Series for 38999 Series III and IV

Shell Size	A Thread	ØB Max.	ØB' Max.	ØG Max.	ØH Max.	C ±0.5	D Max.	E Max.	F Max.	K ±0.5 (0.020)	Recommended Boot Size	M
09	M12 x 1.0	18.0 0.709	20.30 0.799	6.8 0.268	13.5 0.531	13.1 0.516	17.6 0.693	25.7 1.012	25.5 1.004	17.5 0.689	202K121	17.00 0.669
11	M15 x 1.0	21.0 0.827	23.70 0.933	9.9 0.390	15.4 0.606	13.9 0.547	18.4 0.724	26.7 1.051	27.3 1.075	17.5 0.689	202K121	30.40 1.197
13	M18 x 1.0	24.5 0.965	27.15 1.069	13.6 0.535	19.7 0.776	14.5 0.571	19.3 0.760	31.2 1.228	28.7 1.130	20.0 0.787	202K142	23.85 0.939
15	M22 x 1.0	29.0 1.142	32.05 1.262	15.9 0.626	21.3 0.839	15.5 0.610	19.6 0.772	37.2 1.465	30.2 1.189	24.5 0.965	202K142	28.75 1.132
17	M25 x 1.0	32.5 1.280	35.35 1.392	18.9 0.744	24.5 0.965	16.1 0.634	20.4 0.803	40.2 1.583	31.9 1.256	26.7 1.051	202K153	32.05 1.262
19	M28 x 1.0	35.5 1.398	38.55 1.518	21.9 0.862	26.5 1.043	16.8 0.661	20.8 0.819	44.7 1.760	33.5 1.319	27.0 1.063	202K153	35.25 1.388
21	M31 x 1.0	37.0 1.457	39.85 1.569	25.2 0.992	31.0 1.220	17.1 0.673	21.6 0.850	49.2 1.937	35.1 1.382	30.5 1.201	202K153	36.55 1.439
23	M34 x 1.0	40.0 1.575	42.95 1.691	27.4 1.079	34.4 1.354	17.7 0.697	22.5 0.886	51.7 2.035	36.7 1.445	31.5 1.240	202K163	39.65 1.561
25	M37 x 1.0	43.5 1.713	46.12 1.816	30.4 1.197	36.6 1.441	18.4 0.724	22.9 0.902	53.2 2.094	38.1 1.500	28.5 1.122	202K163	42.82 1.686

Millimeters Inches

Entry Size Dimensions

Entry Size	ØG Min.	ØH Max.	No. Of Optional Slots
03	4.7 0.185	13.9 0.547	1
04	6.3 0.248	13.9 0.547	1
05	7.9 0.311	15.5 0.610	1
06	9.5 0.374	17.2 0.677	2
07	11.1 0.437	18.7 0.736	2
08	12.7 0.500	20.3 0.799	2
09	14.2 0.559	21.9 0.862	2
10	15.8 0.622	23.5 0.925	2
11	17.4 0.685	25.1 0.988	2
12	19.0 0.748	26.7 1.051	2
13	20.6 0.811	28.3 1.114	2

Millimeters Inches

Entry Size	ØG Min.	ØH Max.	No. Of Optional Slots
14	22.2 0.874	29.9 1.177	4
15	23.8 0.937	31.5 1.240	4
16	25.4 1.000	33.1 1.303	4
17	27.0 1.063	34.7 1.366	4
18	28.6 1.126	36.3 1.429	4
19	30.2 1.189	37.9 1.492	4
20	31.8 1.252	39.5 1.555	4
21	33.3 1.311	41.1 1.618	4
22	35.0 1.378	42.7 1.681	4
23	36.5 1.437	44.3 1.744	4
24	38.1 1.500	45.9 1.807	4

Millimeters Inches



HIGH PERFORMANCE

- Mesh tape bundle creates windowless EMI barrier, even without overall screen braid
- 360° termination of multiple or individual screens
- Optional heat-shrink boot available for sealing and strain relief

EASY TO USE

- Tool-free termination
- Reworkable

KMA Series Mesh Tape Backshells



The KMA Series backshells are a mesh tape bundle system that creates a windowless EMI barrier, even without overall screen braid by using 360° termination of multiple individual screens.

Part Numbering System

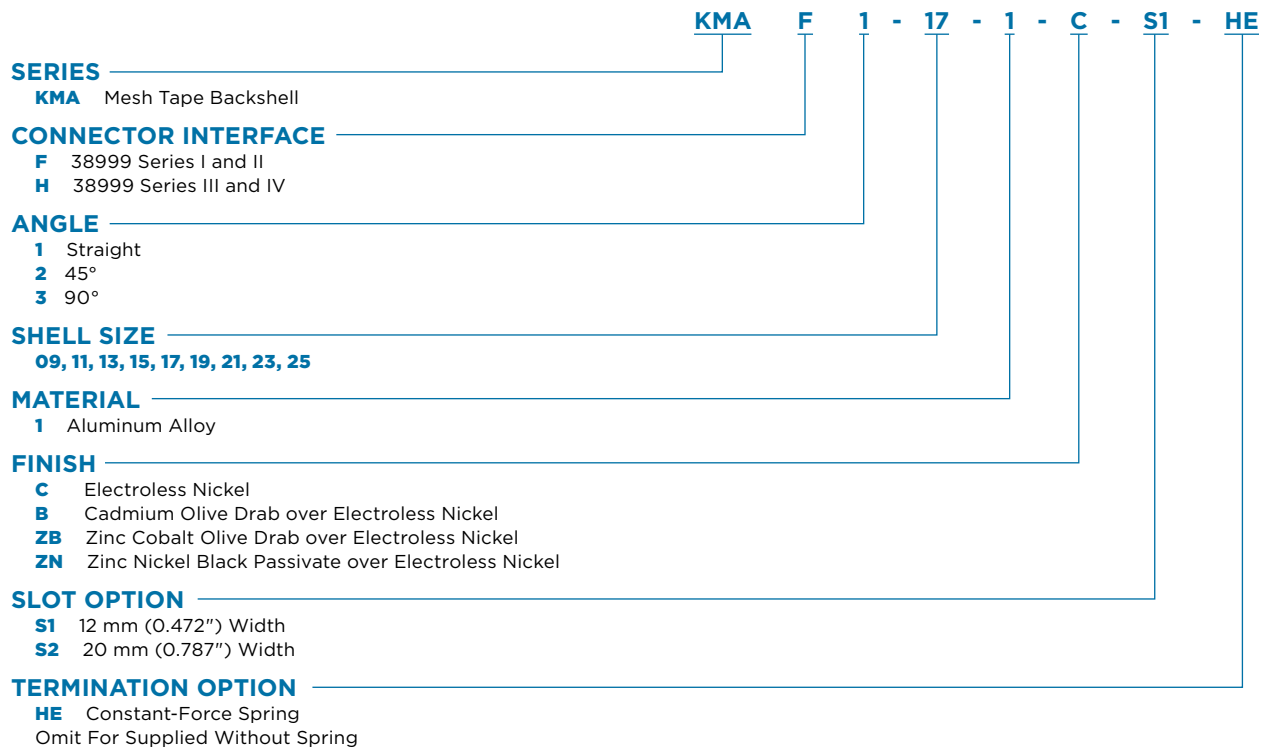



KMA Series Mesh Tape Backshells

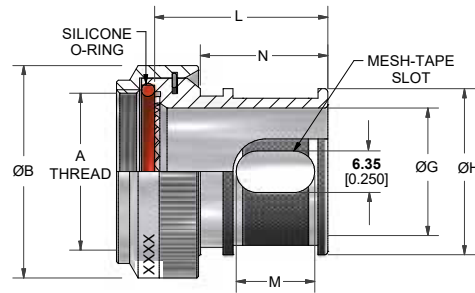

Angle A: Straight

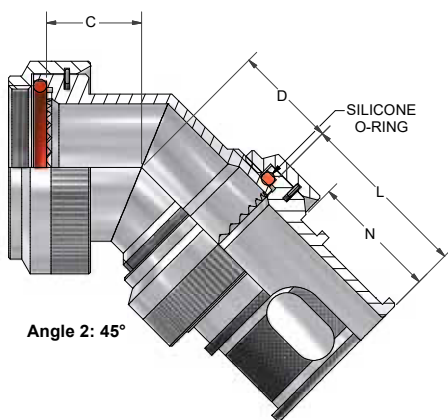

Angle 2: 45°

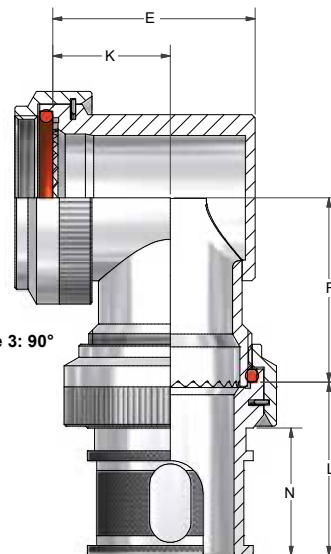

Angle 3: 90°

KMAF Series for 38999 Series I (Consult TE for Series II)

Shell Size	A Thread (UNEF)	ØB Max.	C Max.	D Max.	E Max.	F Max.	K ±0.5 (0.020)	ØG Min.	ØH Max.
09	7/16-28	18.0 0.709	12.5 0.492	14.5 0.571	20.0 0.787	21.5 0.846	13.7 0.539	6.8 0.268	13.2 0.520
11	9/16-24	21.0 0.827	13.0 0.512	15.0 0.591	23.0 0.906	23.0 0.906	14.7 0.579	10.2 0.402	16.7 0.657
13	11/16-24	24.5 0.965	13.6 0.535	15.5 0.610	27.0 1.063	24.5 0.965	17.2 0.677	13.1 0.516	20.0 0.787
15	13/16-20	27.8 1.094	14.0 0.551	16.0 0.630	28.0 1.102	28.5 1.122	16.7 0.657	16.2 0.638	22.7 0.894
17	15/16-20	30.8 1.213	15.0 0.591	17.0 0.669	31.0 1.220	30.0 1.181	18.2 0.717	19.3 0.760	25.4 1.000
19	1-1/16-18	34.1 1.343	16.0 0.630	18.0 0.709	36.0 1.417	31.5 1.240	21.2 0.835	22.3 0.878	28.3 1.114
21	1-3/16-18	37.3 1.469	16.6 0.654	18.5 0.728	39.0 1.535	33.0 1.299	22.2 0.874	25.8 1.016	31.6 1.244
23	1-5/16-18	41.0 1.614	17.0 0.669	19.0 0.748	41.0 1.614	34.5 1.358	23.2 0.913	28.3 1.114	34.7 1.366
25	1-7/16-18	43.7 1.720	17.4 0.685	19.5 0.768	47.0 1.850	36.0 1.417	27.7 1.091	31.5 1.240	37.9 1.492

Millimeters Inches



KMA Series Mesh Tape Backshells

KMAH Series for 38999 Series III and IV

Shell Size	A Thread	ØB Max.	C Max.	D Max.	E Max.	F Max.	K ±0.5 (0.020)	ØG Min.	ØH Max.
09	M12 x 1.0	18.0 0.709	12.5 0.492	14.5 0.571	20.0 0.787	21.5 0.846	13.5 0.531	6.8 0.268	13.2 0.520
11	M15 x 1.0	21.0 0.827	13.0 0.512	15.0 0.591	23.0 0.906	23.0 0.906	14.5 0.571	10.3 0.406	16.7 0.657
13	M18 x 1.0	24.5 0.965	13.6 0.535	15.5 0.610	27.0 1.063	24.5 0.965	17.0 0.669	13.6 0.535	20.0 0.787
15	M22 x 1.0	29.0 1.142	14.0 0.551	16.0 0.630	28.0 1.102	28.5 1.122	16.5 0.650	16.3 0.642	22.7 0.894
17	M25 x 1.0	32.5 1.280	15.0 0.591	17.0 0.669	31.0 1.220	30.0 1.181	18.0 0.709	19.5 0.768	25.4 1.000
19	M28 x 1.0	35.5 1.398	16.0 0.630	18.0 0.709	36.0 1.417	31.5 1.240	21.0 0.827	21.9 0.862	28.3 1.114
21	M31 x 1.0	37.0 1.457	16.6 0.654	18.5 0.728	39.0 1.535	33.0 1.299	22.0 0.866	25.2 0.992	31.6 1.244
23	M34x1.0	40.0 1.575	17.0 0.669	19.0 0.748	41.0 1.614	34.5 1.358	23.0 0.906	28.3 1.114	34.7 1.366
25	M37x1.0	43.5 1.713	17.4 0.685	19.5 0.768	47.0 1.850	36.0 1.417	27.5 1.083	31.5 1.240	37.9 1.492

Millimeters Inches



INDUSTRY STANDARD

- Meets AS85049 NAVAIR standards

RELIABLE

- Self-coupling locking nut provides excellent mechanical protection against loosening under vibration
- Corrosion resistant stainless steel

EASY TO USE

- Band straps available flat for side entry or precoiled for end entry
- Side-entry band straps allow easier installation and repair

VERSATILE

- Three band strap widths

Raychem AS85049 Band Straps



The AS85049 industry standard is used on most military circular connectors, including M38999. The band strap termination system provides ease of installation and repair. TE offers the corrosion-resisting steel bands in three styles to help meet your shield termination needs and termination tool of your choice.

APPLICATION TOOLING

- M85049/128-7 & 8 AS81306/1-02
- M85049/128-3 & 4 AS81306/1-01
- M85049/128-1 & 2 AS81306/2-01

Part Numbering System

M85049/128 - X

CONFIGURATION

- 1** Flat, 6.22 (0.245) Width
- 2** Precoiled, 6.22 (0.245) Width
- 3** Flat, 6.35 (0.250) Width
- 4** Precoiled, , 6.35 (0.250) Width
- 7** Flat, 3.05 (0.120) Width
- 8** Precoiled, 3.05 (0.120) Width



Raychem AS85049 Band Straps

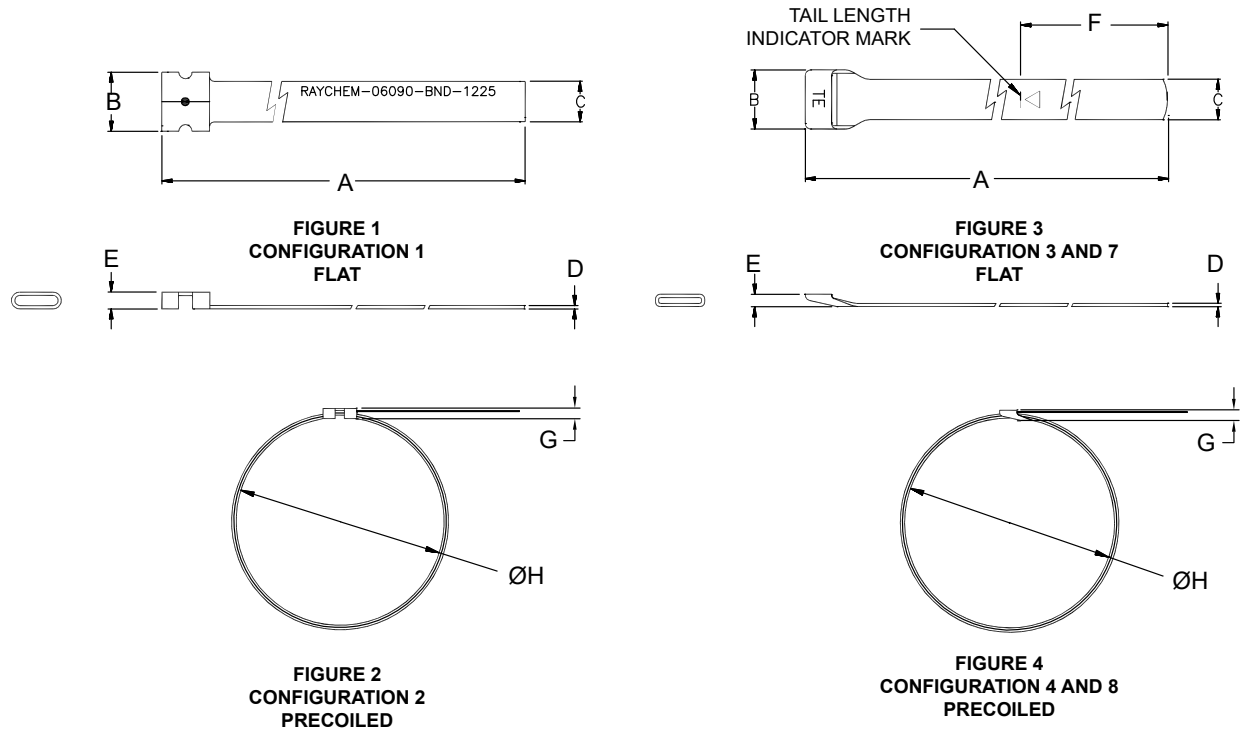

Configurations and Dimensions

Configuration	Figure	A ± 1.52 (.060)	B ± 0.79 (.031)	C ± 0.25 (.010)	D Ref.	E Ref.	F Ref.	G Max.	H Ref.
1	1	355.6 14.0	8.33 0.328	6.22 0.245	0.48 0.019	2.54 0.100	—	—	—
2	2	—	—	—	—	—	—	3.56 0.140	44.46 1.750
3	3	362.10 14.526	8.89 0.350	6.35 0.250	0.51 0.020	3.30 0.130	51.59 2.031	—	—
4	4	—	—	—	—	—	—	3.81 0.150	44.45 1.750
7	3	206.38 8.125	4.95 0.195	3.05 0.120	0.38 0.015	1.35 0.053	51.59 2.031	—	—
8	4	—	—	—	—	—	—	1.85 0.073	21.8 0.860

Millimeters Inches



Raychem AS85049 Adapters and Bandstraps

INDUSTRY STANDARD

- Meets AS85049 NAVAIR standards
- Terminates a shielded cable

RELIABLE

- Detented self-locking coupling nut with audible click
- Sealed adapter-to-connector interface
- Accepts lipped heat-shrinkable boots

VERSATILE

- Straight, 45°, and 90° configurations
- Cadmium, electroless nickel, or black zinc nickel plating

APPLICATIONS

- Aerospace
- Marine
- Military Ground Vehicles
- Space-Based Systems



Meeting NAVAIR requirements, Raychem AS85049 adapters help provide a reliable termination of shielded cables. The detented self-locking coupling nut helps provide mechanical protection against loosening under vibration and provides audible indication of proper engagement.

MATERIALS

- **Adapters:** Aluminum
- **Plating:** Olive drab cadmium, electroless nickel, or black zinc nickel

Part Numbering System

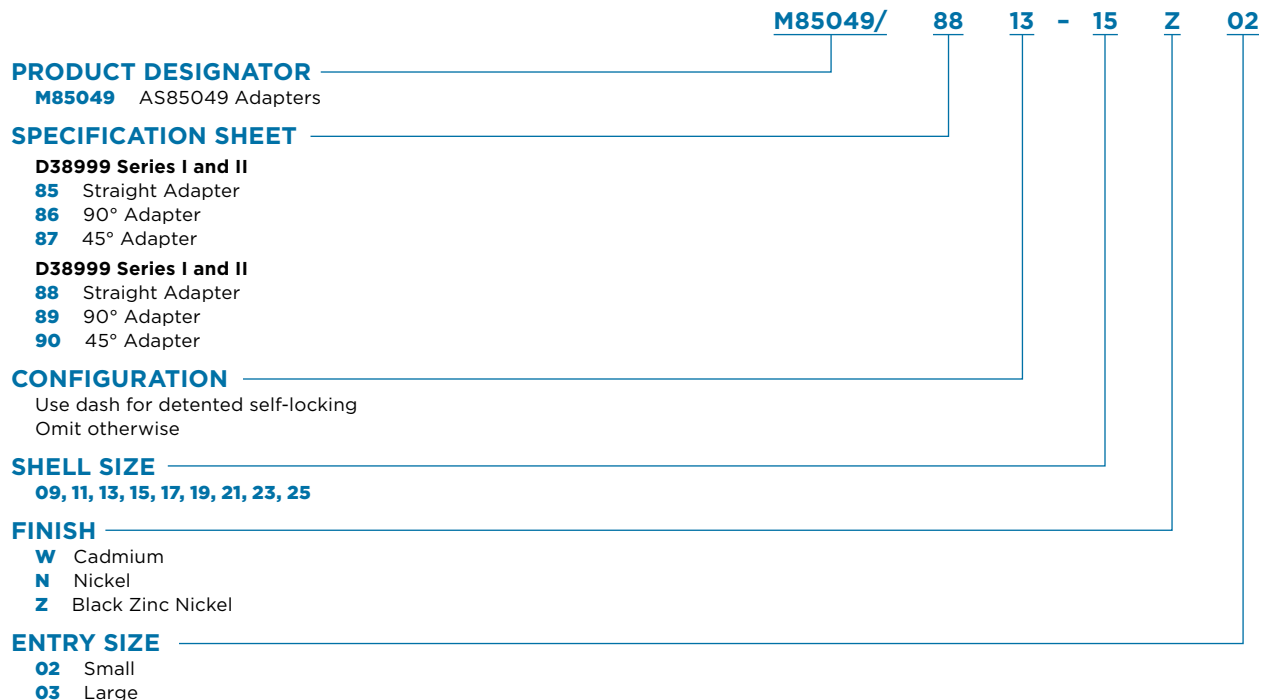



Raychem AS85049 Adapters and Bandstraps

Straight Adapters

AS85049/85 Adapters for 38999 Series I and II

AS85049/88 Adapters for 38999 Series III and IV

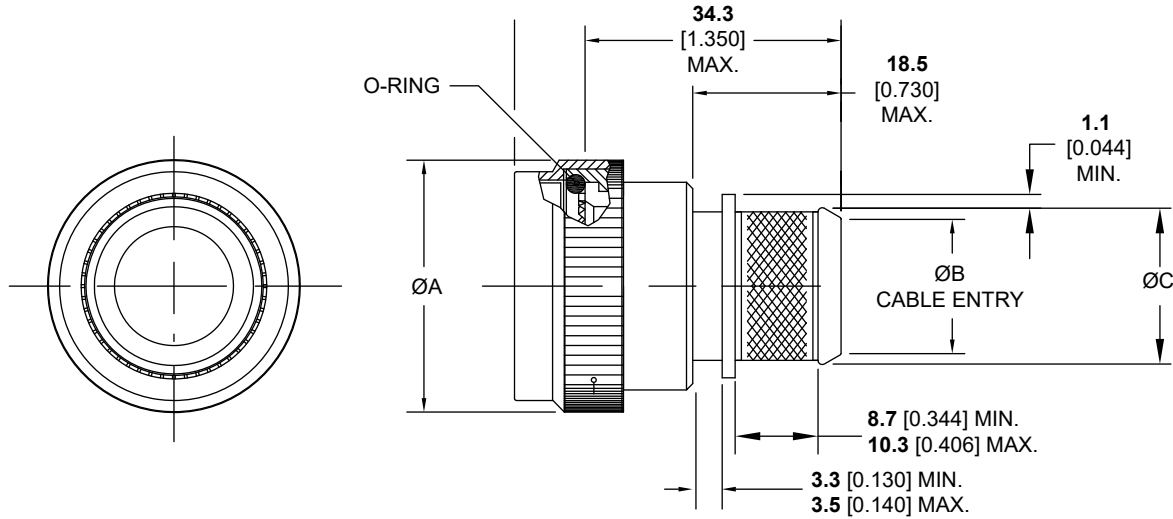

Shell Size	A Dia. Max.	B Dia. ±.010		C Dia. Ref		
		02	03	02	03	
9	A	21.8 0.858	N/A	6.4 0.250	N/A	10.0 0.395
11	B	25.0 0.984	N/A	7.9 0.312	N/A	11.6 0.457
13	C	29.4 1.157	7.9 0.312	11.1 0.438	11.6 0.457	14.8 0.583
15	D	32.5 1.279	11.1 0.438	14.3 0.562	14.8 0.583	18.0 0.707
17	E	35.7 1.406	12.7 0.500	15.9 0.625	16.4 0.645	19.6 0.770
19	F	38.5 1.516	15.9 0.625	19.1 0.750	19.6 0.770	22.7 0.895
21	G	41.7 1.642	15.9 0.625	20.6 0.812	19.6 0.770	24.3 0.957
23	H	44.9 1.768	17.5 0.688	23.8 0.938	21.1 0.829	27.5 1.083
25	J	48.0 1.889	19.1 0.750	25.4 1.000	22.7 0.895	29.1 1.145

Millimeters Inches



Raychem AS85049 Adapters and Bandstraps

45° Adapters

AS85049/86 Adapters for 38999 Series I and II

AS85049/89 Adapters for 38999 Series III and IV

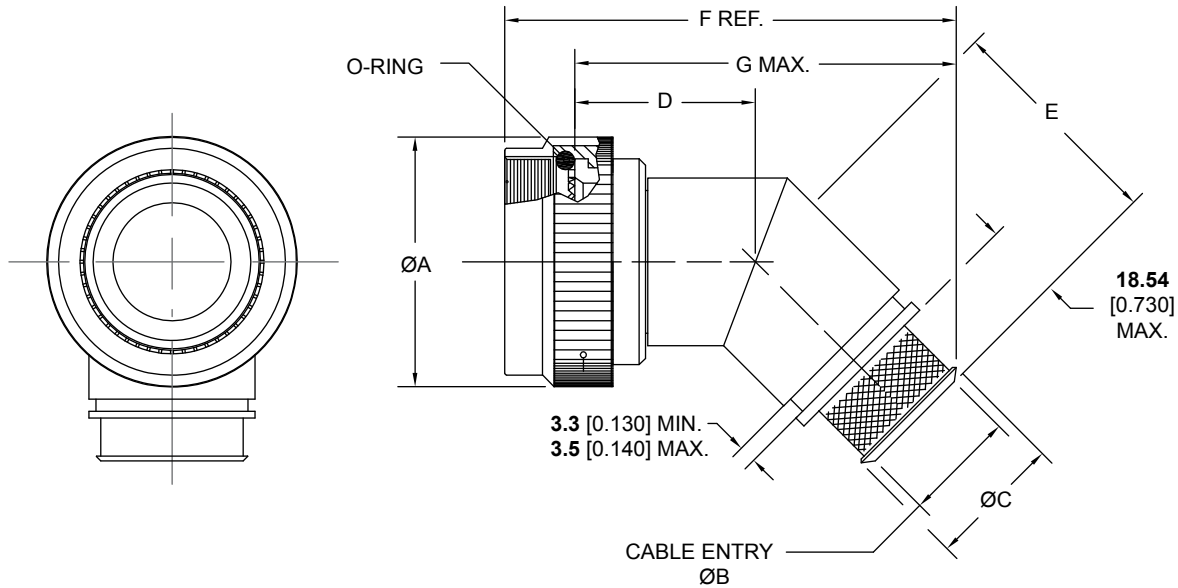

Shell Size	A Dia. Max.	B Dia. ±.010		C Dia. Ref		D	E	F Ref.		G Max.		
		02	03	02	03			02	03	02	03	
9	A	21.8 0.858	N/A	6.4 0.250	N/A	10.0 0.395	25.7 1.01	29.5 1.16	N/A	56.3 2.22	N/A	50.0 1.97
11	B	25.0 0.984	N/A	7.9 0.312	N/A	11.6 0.457	26.2 1.03	30.2 1.19	N/A	57.9 2.28	N/A	51.6 2.03
13	C	29.4 1.157	7.9 0.312	11.1 0.438	11.6 0.457	14.8 0.583	26.9 1.06	30.7 1.21	59.1 2.33	60.2 2.37	52.8 2.08	53.9 2.12
15	D	32.5 1.279	11.1 0.438	14.3 0.562	14.8 0.583	18.0 0.707	27.4 1.08	31.5 1.24	61.2 2.41	62.4 2.46	54.9 2.16	56.1 2.21
17	E	35.7 1.406	12.7 0.500	15.9 0.625	16.4 0.645	19.6 0.770	28.2 1.11	32.0 1.26	62.9 2.48	64.0 2.52	56.6 2.23	57.7 2.27
19	F	38.5 1.516	15.9 0.625	19.1 0.750	19.6 0.770	22.7 0.895	28.4 1.12	32.3 1.27	64.5 2.54	65.6 2.58	58.2 2.29	59.3 2.33
21	G	41.7 1.642	15.9 0.625	20.6 0.812	19.6 0.770	24.3 0.957	29.2 1.15	33.0 1.30	65.8 2.59	67.5 2.66	59.5 2.34	61.2 2.41
23	H	44.9 1.768	17.5 0.688	23.8 0.938	21.1 0.829	27.5 1.083	29.7 1.17	33.8 1.33	67.4 2.65	69.6 2.74	61.1 2.40	63.3 2.49
25	J	48.0 1.889	19.1 0.750	25.4 1.000	22.7 0.895	29.1 1.145	30.5 1.20	34.3 1.35	69.1 2.72	71.3 2.81	62.8 2.47	65.0 2.56

Millimeters Inches



Raychem AS85049 Adapters and Bandstraps

90° Adapters

AS85049/87 Adapters for 38999 Series I and II

AS85049/90 Adapters for 38999 Series III and IV

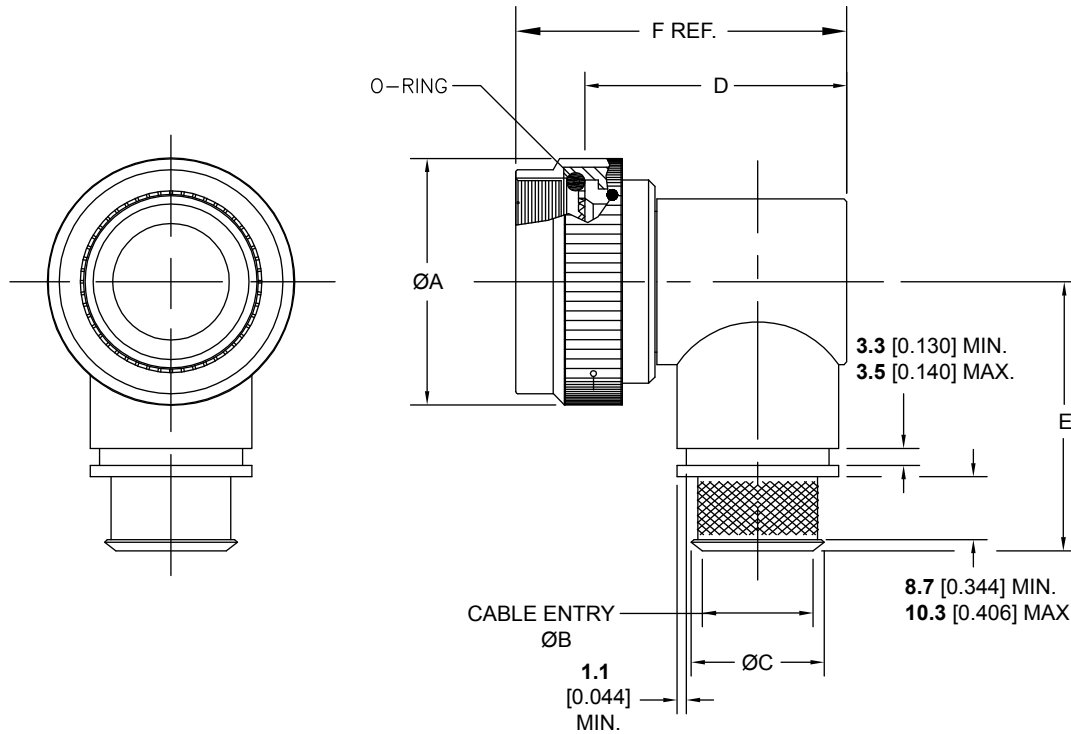

Shell Size	A Dia. Max.	B Dia. ±.010		C Dia. Ref		D	E	F Ref.	
		02	03	02	03				
9	A	21.8 0.858	N/A	6.4 0.250	N/A	10.0 0.395	34.9 1.375	36.0 1.417	41.2 1.623
11	B	25.0 0.984	N/A	7.9 0.312	N/A	11.6 0.457	36.5 1.437	37.6 1.480	42.8 1.685
13	C	29.4 1.157	7.9 0.312	11.1 0.438	11.6 0.457	14.8 0.583	39.7 1.562	39.4 1.553	46.0 1.810
15	D	32.5 1.279	11.1 0.438	14.3 0.562	14.8 0.583	18.0 0.707	42.8 1.687	41.0 1.614	49.1 1.935
17	E	35.7 1.406	12.7 0.500	15.9 0.625	16.4 0.645	19.6 0.770	44.4 1.750	42.6 1.678	50.8 1.998
19	F	38.5 1.516	15.9 0.625	19.1 0.750	19.6 0.770	22.7 0.895	47.6 1.875	45.0 1.773	53.9 2.123
21	G	41.7 1.642	15.9 0.625	20.6 0.812	19.6 0.770	24.3 0.957	49.2 1.938	45.6 1.796	55.5 2.186
23	H	44.9 1.768	17.5 0.688	23.8 0.938	21.1 0.829	27.5 1.083	52.4 2.062	47.2 1.859	58.7 2.310
25	J	48.0 1.889	19.1 0.750	25.4 1.000	22.7 0.895	29.1 1.145	54.0 2.125	48.7 1.919	60.3 2.373

Millimeters Inches



Raychem AS85049 Adapters and Bandstraps

AS85049/128 Band Straps

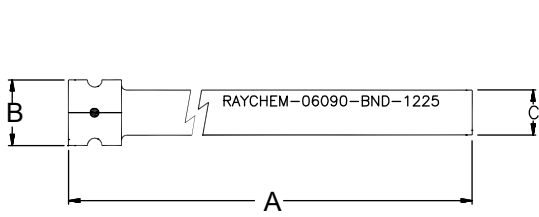

**FIGURE 1
CONFIGURATION 1
FLAT**

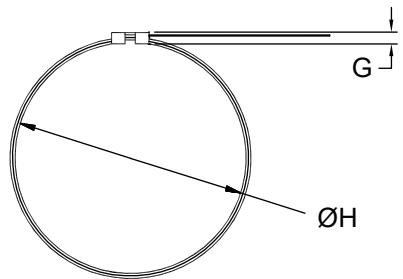
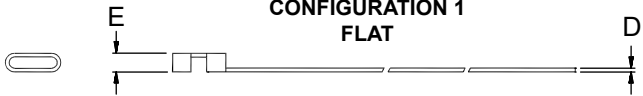

**FIGURE 2
CONFIGURATION 2
PRECOILED**

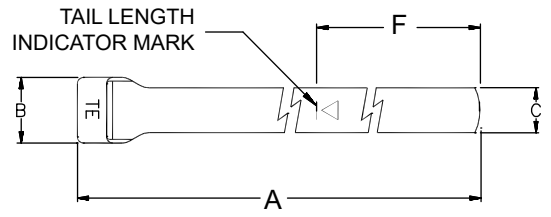

**FIGURE 3
CONFIGURATION 3 AND 7
FLAT**



**FIGURE 4
CONFIGURATION 4 AND 8
PRECOILED**

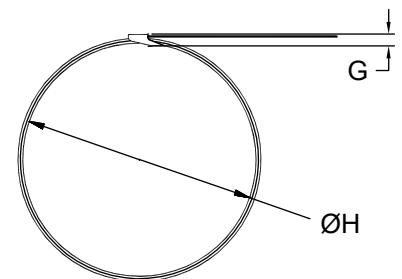



HIGH PERFORMANCE

- Excellent EMC shielding performance
- Excellent mechanical and environmental resistance
- Provides strain relief on each individual cable

EASY TO USE

- One-piece assembly for simple installation
- Easy reentry
- Simplified maintenance and repair

VERSATILE

- Accommodates up to four shielded cables per ferrule
- Compact size for easy installation in confined areas
- Available for circular connectors in straight, 45°, and 90° assemblies, plus swept and long bodies.

APPLICATIONS

- Civilian and military aircraft
- Avionics
- Missiles and launch support systems
- Armored and military support vehicles
- Military ships (total shipboard hardening)
- Military communications
- Engines (FADEC harness hardening)

Raychem HexaShield EMC Adaptors



High-Performance EMC Protection for Harsh Military and Commercial Environments

Raychem HexaShield high-performance adaptors help provide excellent EMC protection and reliability in a variety of military and commercial applications.

Easy to install, maintain and repair, HexaShield adaptors help provide outstanding shielding effectiveness by providing 360-degree EMC shielding on the termination area of each individual cable. They are available for circular connectors in a variety of angles, plus swept and long body configurations.

HexaShield adaptors outperform traditional pigtail terminations, especially in HIRF application. They provide excellent EMC protection with minimal degradation of shielding performance. The adaptors also help provide excellent mechanical and environmental protection.

Specifications

MATERIALS

- **Shell:** Aluminum alloy
- **Platings:** Electroless nickel (MIL-DTL-26074) or olive drab cadmium (QQ-P-416 Type II, Class 3)

INSTALLATION PROCEDURES

- **RPIP-696-00:** HEX-A-02X and HET-A-04X
- **RPIP-696-03:** HET-03X

GENERAL PROCEDURES

- **RPIP-696-07:** Cylindrical connectors, right-angle body
- **RPIP-696-04:** Cylindrical connectors, straight body



Raychem HexaShield EMC Adaptors

HexaShield Adaptors for Circular Connectors

Straight Backshells

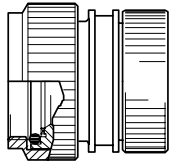

45° Backshells

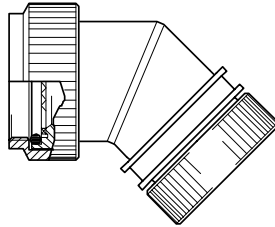

90° Backshells

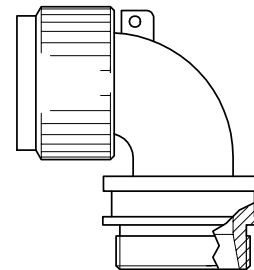
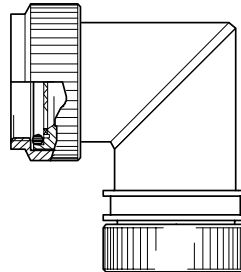

Swept Version

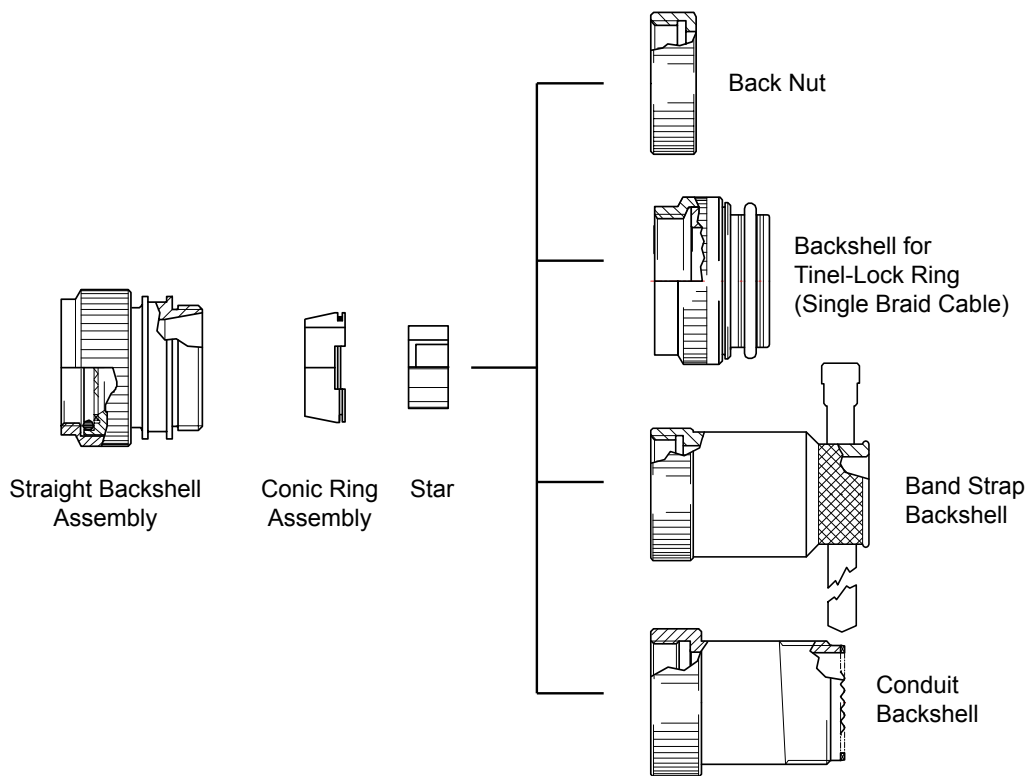



Raychem HexaShield EMC Adaptors

HexaShield Adaptor for Circular Connectors

Part Numbering System

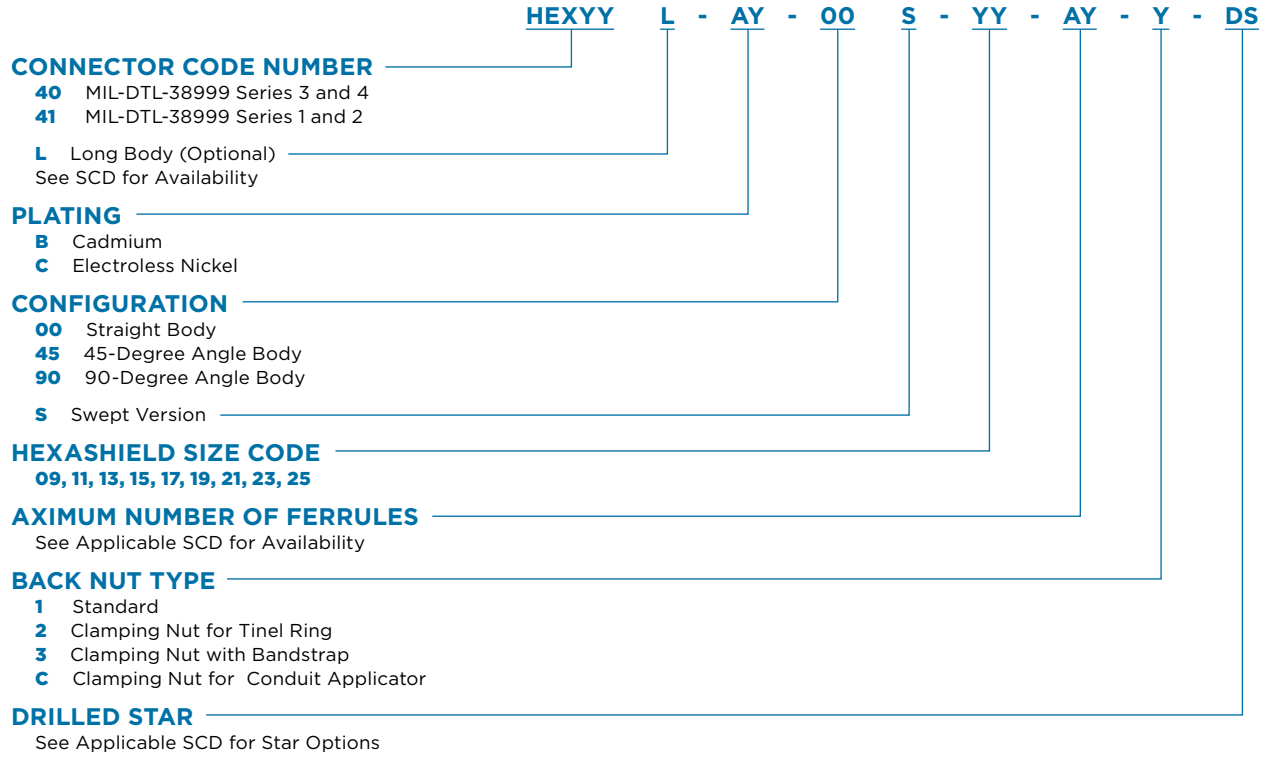

HexaShield Ferrule Kits

Use	Part No.	
	Cadmium Finish	Electroless Nickel Finish
Small-Size Cable with SolderShield Terminator	HET-A-02B	HET-A-02C
Ferrules with Heat-Shrinkable Tubing for Unshielded Cables	HET-A-03B	HET-A-03C
Large-Size Cable with SolderShield Terminator	HET-A-04B	HET-A-04C
Ferrule, Solid Blank for Use When HET-A Is Not Needed	HEX07-AB	HEX07-AC



Raychem HexaShield EMC Adaptors

Generalized System Performance

(Actual system performance in any one test method may differ.)

Transfer Impedance

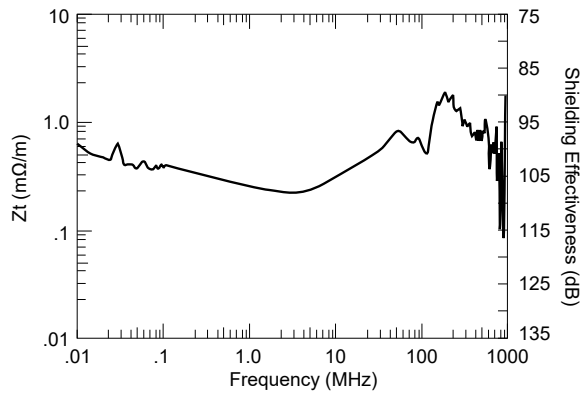

Protection Level

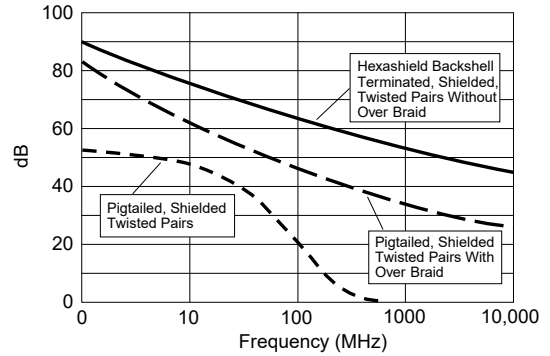

Frequency Spectrum of Threats

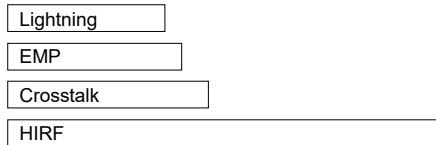

Frequency Spectrum Of Test Methods

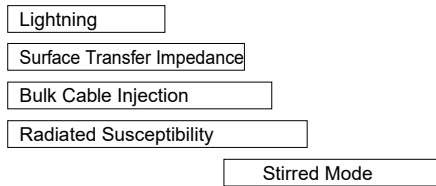



WEIGHT-SAVING DESIGN

- Lightweight composite materials
- Simple design helps to minimize amount of material
- Well suited to light-duty applications

SEALED

- Grommets provide sealing of individual wires

ACT00 Lightweight Composite Tie-Style Strain Relief Adapters

ACT00 strain relief adapters offer composite bodies to help provide a simple, lightweight strain relief for cable uses in light-duty application. Cable can be secured to the body adapter with a tie wrap. Body adapters are available with various conductive platings to help support grounding, while a secondary grommet provides wire sealing.

The adapters are available with inserts to match the insert arrangement of the connector on which it is used.

MATERIALS

- Coupling Nut and Body Adapter: Composite
- Body Adapter Finish: Nickel, tin, or olive drab cadmium
- Secondary Grommet: Silicone elastomer

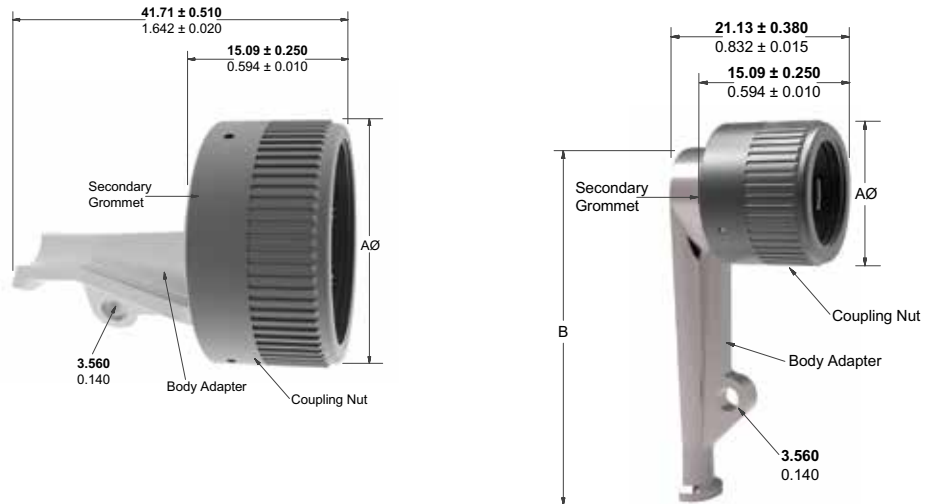

Shell Size	ØA ±0.15 (0.006)	B ±0.80 (0.031)	Strength Bending Moment, Min. (kg, lb.)
9 (A)	0.650 0.026	1.948 0.077	11 25
11 (B)	0.775 0.031	2.010 0.079	11 25
13 (C)	0.905 0.036	2.075 0.082	11 25
15 (D)	1.030 0.041	2.135 0.084	22 50
17 (E)	1.160 0.046	2.198 0.087	22 50
19 (F)	1.270 0.050	2.258 0.089	22 50
21 (G)	1.400 0.055	2.320 0.091	34 75
23 (H)	1.525 0.060	2.383 0.094	34 75
25 (J)	1.655 0.065	2.445 0.096	45 100

Millimeters Inches



ACT00 Lightweight Composite Tie-Style Strain Relief Adapters

Part Numbering System

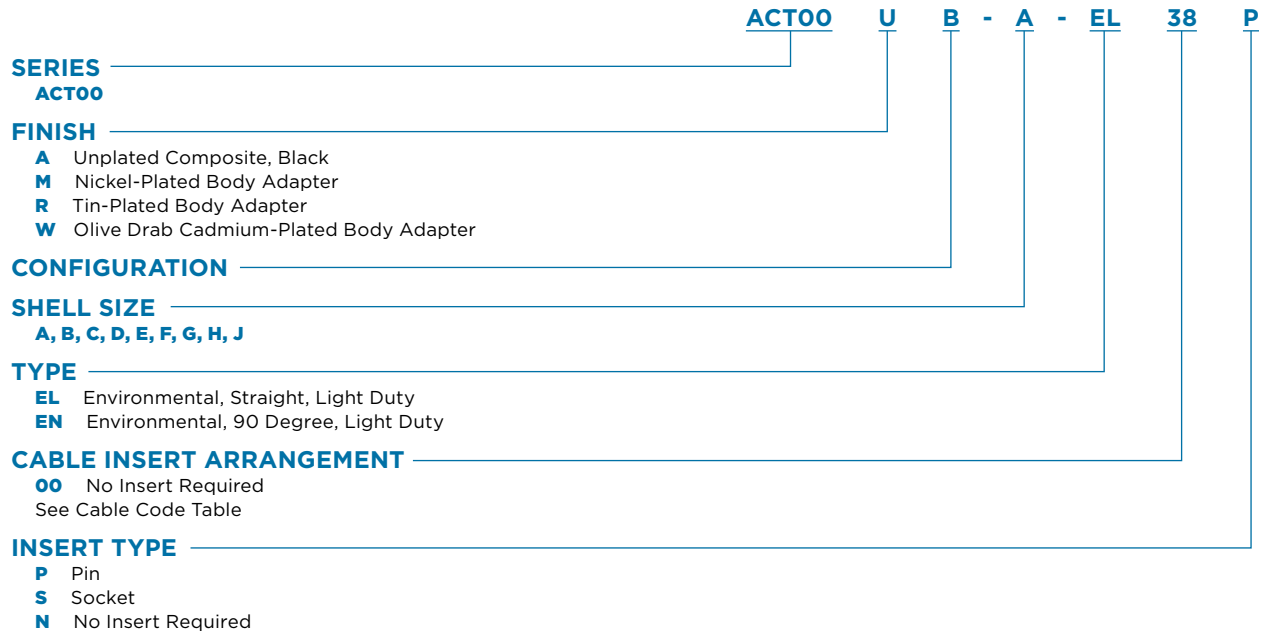

Cable Code Table: Use to Specify the Insert Arrangement

Cable Code	Insert Arrangement	Cable Code	Insert Arrangement	Cable Code	Insert Arrangement
38	09-35	53	17-35	68	25-24
39	09-98	54	19-11	69	25-29
40	11-05	55	19-32	70	25-35
41	11-35	56	19-35	71	25-61
42	11-99	57	21-11	92	11-98
43	13-04	58	21-16	93	15-19
44	13-35	59	21-35	94	13-08
45	13-98	60	21-41	95	17-99
46	15-05	61	23-21	96	21-39
47	15-18	62	23-35	97	25-43
48	15-35	63	23-53	98	15-23
49	15-97	64	23-55	99	17-19
50	17-06	65	25-04	100	15-26
51	17-08	66	25-19		
52	17-26	67	25-20		



ACT00 Lightweight Composite Tie-Style Strain Relief Adapters

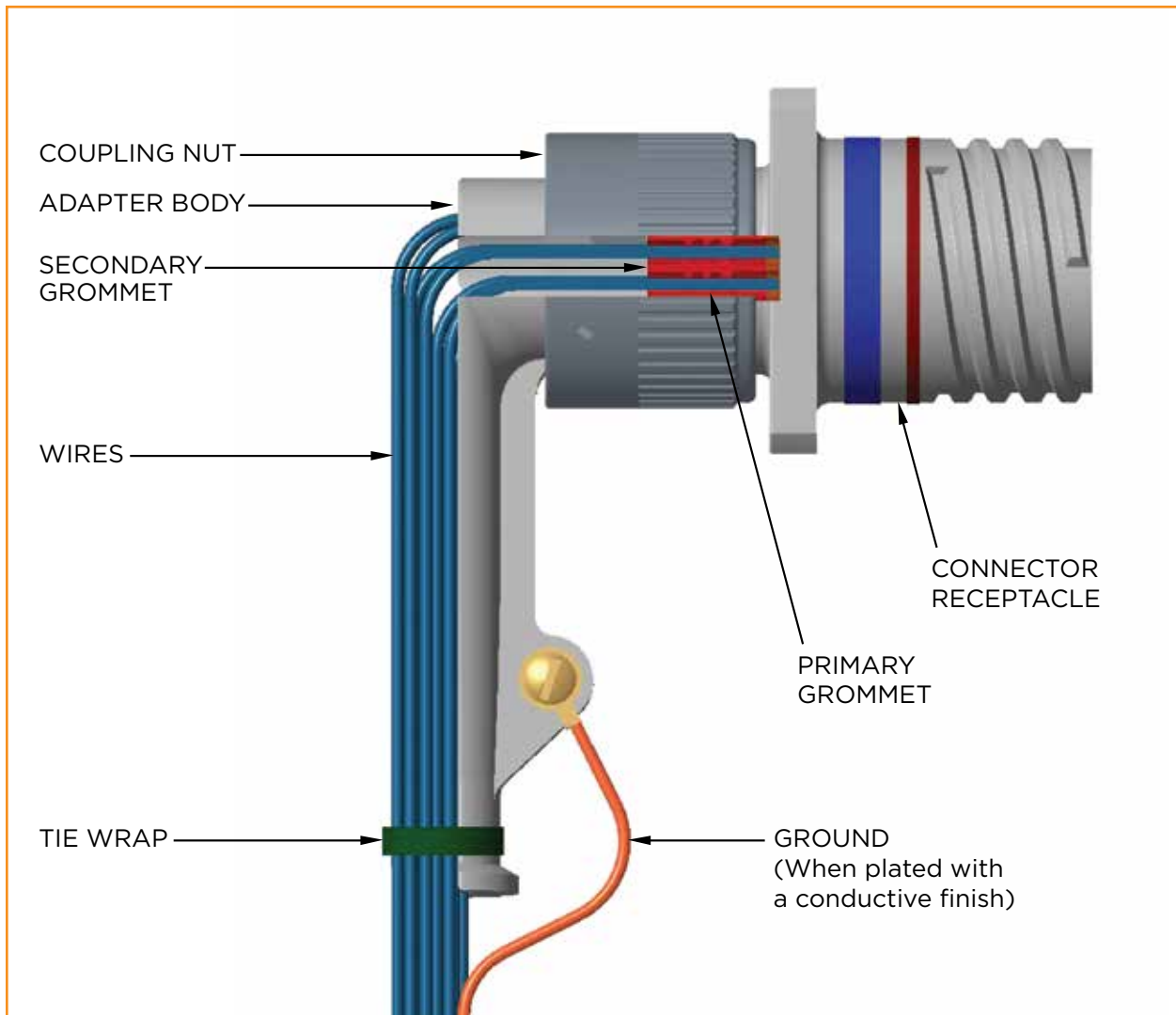



38999-Style Accessories

Metal Protective Covers

**Series III
Plug Cap**
(with attachment)

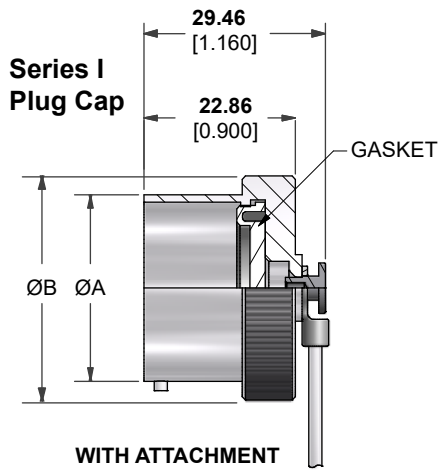

Shell Size	A Max.	B Max.
09	14.56 0.573	20.83 0.820
11	17.81 0.701	23.88 0.940
13	21.62 0.851	27.18 1.070
15	24.84 0.978	30.23 1.190
17	28.02 1.103	33.53 1.320
19	30.73 1.210	36.58 1.440
21	33.91 1.335	39.88 1.570
23	37.08 1.460	42.92 1.690
25	40.26 1.585	46.23 1.820

Millimeters Inches

**Series I
Receptacle Cap**
(with attachment)

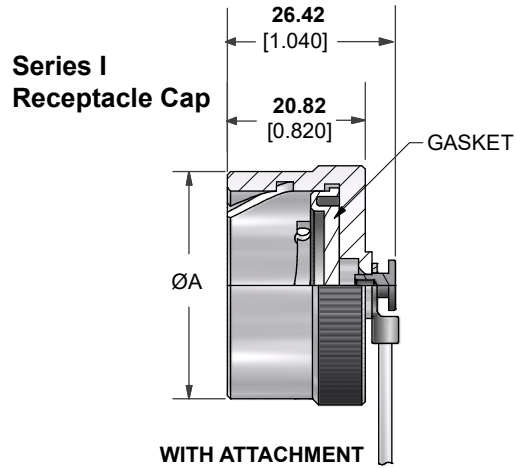

Shell Size	A Max.
09	21.84 0.860
11	24.89 0.980
13	29.46 1.160
15	32.51 1.280
17	35.81 1.410
19	38.61 1.520
21	41.91 1.650
23	44.96 1.770
25	48.00 1.890

Millimeters Inches



38999-Style Accessories

Metal Protective Covers

Series III

Plug Cap

(with attachment)

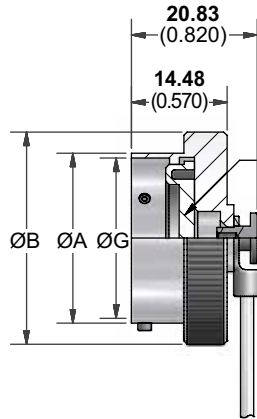

Shell Size	ØA +0.03/-0.13 (0.001/0.005)	ØB Max.	ØG Min.
08	12.00 0.472	18.28 0.720	10.60 0.417
10	14.99 0.590	21.59 0.850	13.72 0.540
12	19.05 0.750	25.40 1.000	17.50 0.689
14	22.23 0.875	28.70 1.130	20.67 0.814
16	25.40 1.000	31.75 1.250	24.00 0.945
18	28.58 1.125	35.05 1.380	26.39 1.039
20	31.75 1.250	38.10 1.500	29.60 1.165
22	34.93 1.375	41.40 1.630	32.74 1.289
24	38.10 1.500	44.45 1.750	35.92 1.414

Millimeters Inches



38999-Style Accessories

Metal Protective Covers

Series III Plug Cap (with attachment)

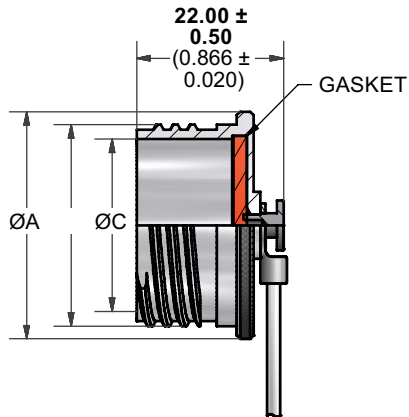

Shell Size	ØA Max.	ØC Min.
09	21.0 0.827	12.6 0.496
11	24.5 0.965	15.8 0.622
13	28.0 1.102	19.4 0.764
15	30.0 1.181	22.6 0.890
17	34.0 1.339	25.8 1.016
19	37.0 1.457	28.6 1.126
21	40.0 1.575	31.8 1.252
23	43.0 1.693	34.8 1.370
25	47.0 1.850	38.1 1.500

Millimeters Inches

Series III Receptacle Cap (with attachment)

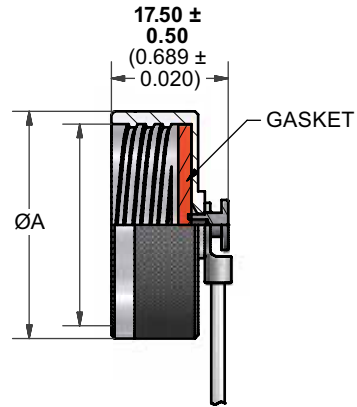

Shell Size	ØA Max.
09	18.0 0.709
11	21.4 0.843
13	25.8 1.016
15	28.8 1.134
17	32.0 1.260
19	35.0 1.378
21	38.3 1.508
23	41.7 1.642
25	44.6 1.756

Millimeters Inches



38999-Style Accessories

Metal Protective Covers

Series III Anti-Decoupling Cap (with attachment)

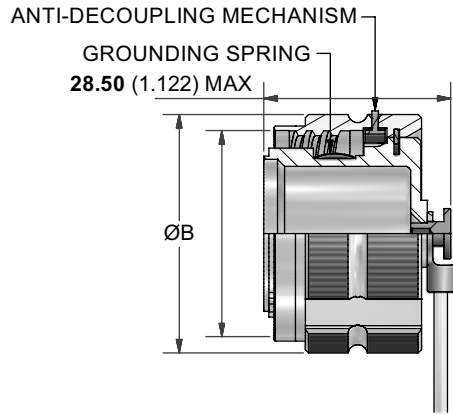

Shell Size	ØB Max.
09	21.8 0.858
11	25.0 0.984
13	29.4 1.157
15	32.5 1.280
17	35.7 1.406
19	38.5 1.516
21	41.7 1.642
23	44.9 1.768
25	48.0 1.890

Millimeters Inches

Series III Anti-Tamper Cap (with attachment)

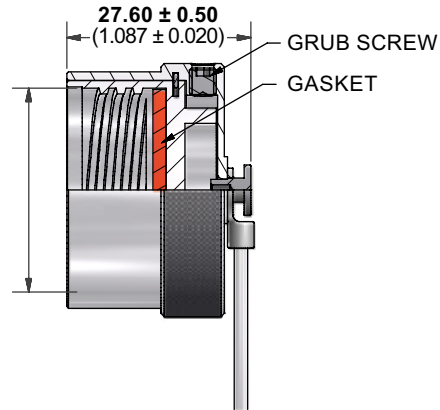

Shell Size	ØB Max.
09	22.6 0.890
11	26.1 1.028
13	29.3 1.154
15	32.5 1.280
17	37.9 1.492
19	38.8 1.528
21	42.0 1.654
23	45.5 1.791
25	50.3 1.980

Millimeters Inches



38999-Style Accessories

Metal Protective Covers

Series III Arctic Grip Plug Cap (with attachment)

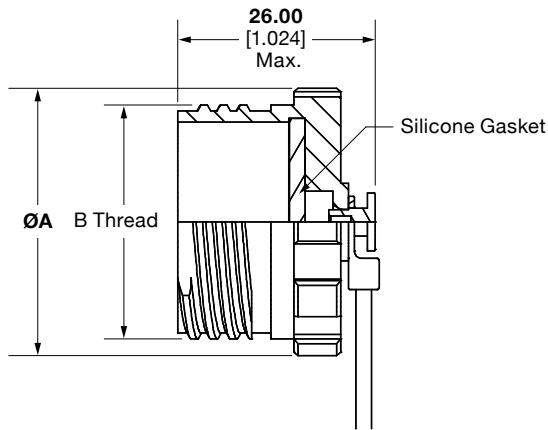

Shell Size	ØA Max.
09	21.0 0.827
11	25.0 0.984
13	28.0 1.102
15	31.0 1.220
17	35.0 1.378
19	37.0 1.457
21	40.0 1.575
23	43.0 1.693
25	47.0 1.850

Millimeters Inches

Series III Arctic Grip Receptacle Cap (with attachment)

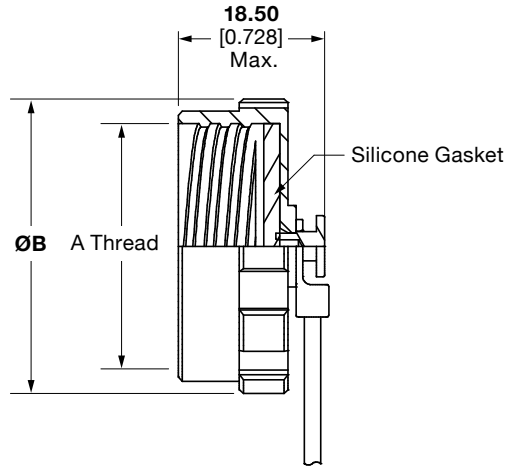

Shell Size	ØB Max.
09	23.7 0.933
11	27.2 1.071
13	30.7 1.209
15	32.7 1.287
17	36.7 1.445
19	39.7 1.563
21	42.7 1.681
23	45.7 1.799
25	49.7 1.957

Millimeters Inches



Metal Protective Covers for 38999 Series III

POLAMCO Protective Caps - Lanyard Options

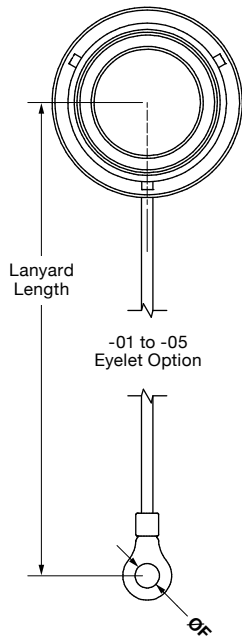

Code	ØF Max.
01	3.2 0.126
02	3.7 0.146
03	4.3 0.169
04	5.3 0.209
05	6.4 0.252

Millimeters Inches

-09 to -25 Ring Option
(fits over accessory thread)

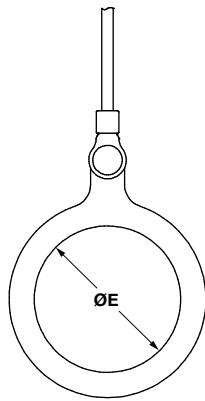

Code	ØE Max.
09	18.0 0.709
11	21.4 0.843
13	25.8 1.016
15	28.8 1.134
17	32.0 1.260

Millimeters Inches

-S09 to -S25 Split Ring Option

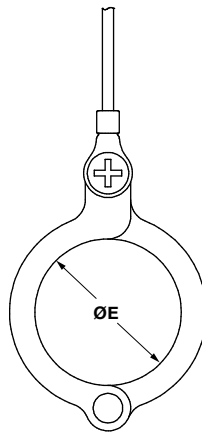

Code	ØE Max.
19	35.0 1.378
21	38.3 1.508
23	41.7 1.642
25	44.6 1.756

Millimeters Inches

ATTACHMENT OPTIONS:

-CF Crimp Ferrule Option

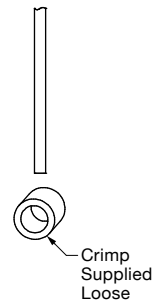

-00 No Termination

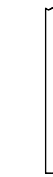

-TR Tie-Wrap Option

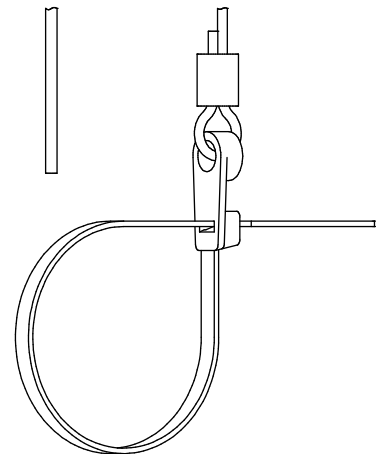



RUGGED

- Helps protect connectors that are mated and unmated frequently
- Serves as an intermediary between plug and receptacle connector
- Available in MIL-DTL-38999 Series III and IV styles

VERSATILE

- One-piece connectors with plug and receptacle interfaces
- Choice of aluminum, stainless steel, or marine bronze shells
- Wide range of plating options

POLAMCO Connector Savers



38999-Style Series III and Series IV Connectors

POLAMCO Connector Savers help protect connectors that are mated and unmated frequently. The one-piece connectors use plug interface on one end and a receptacle interface on the other to allow them to serve as an intermediary between plug and receptacle connector. This helps allow the connector saver to take the wear and tear of repeated mating cycles. In particular, this helps allow box-mounted receptacles to be more protected from wear and the eventual need to be replaced.

POLAMCO connector savers are available in both MIL-DTL-38999 Series III and IV styles. Options include aluminum, stainless steel, or marine bronze shells with a wide range of plating options.

- **Shell Material:** Aluminum, stainless steel, or nickel aluminum bronze
- **Finish:** See part numbering description
- **Seals:** Silicone elastomer
- **Insert:** Thermoset plastic
- **Contacts:** Copper alloy, gold plated



POLAMCO Connector Savers

38999-Style Series III and Series IV Connectors

Series III Connector Saver

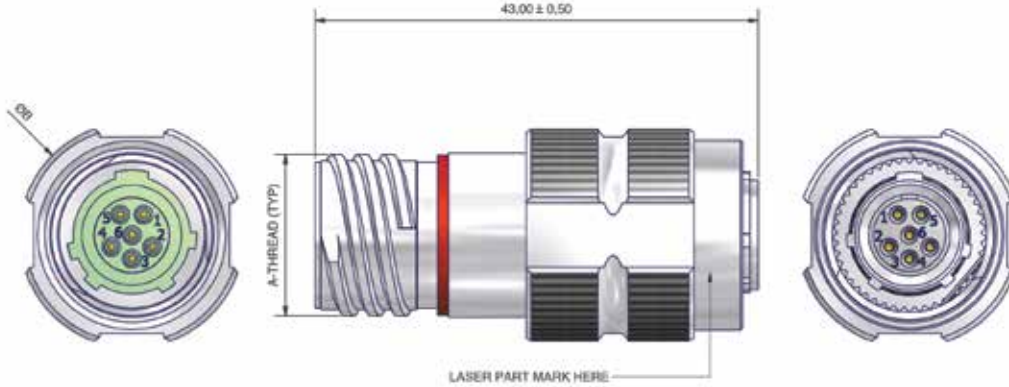

Series IV Connector Saver

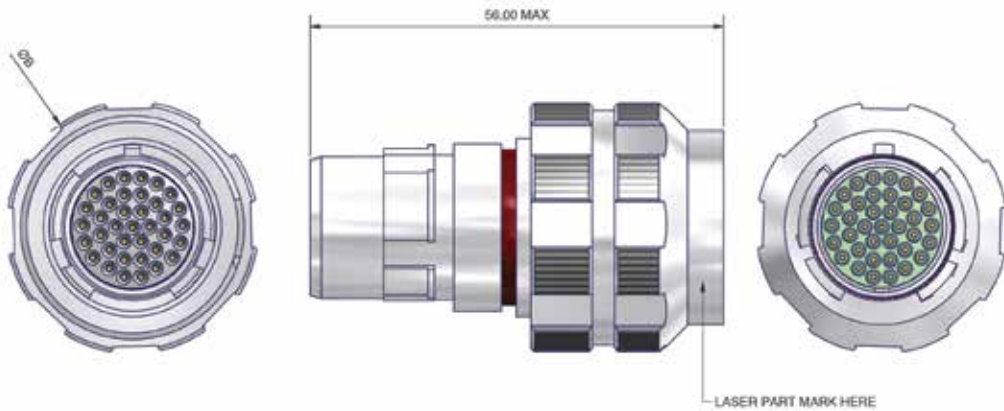

Shell Size	Ø B	
	Series III	Series IV
9	21.8 0.858	—
11	25.0 0.984	26.6 1.047
13	29.4 1.157	31.0 1.220
15	32.5 1.280	34.2 1.346
17	35.7 1.406	37.4 1.472
19	38.5 1.516	40.2 1.583
21	41.7 1.642	43.3 1.705
23	44.9 1.768	46.5 1.831
25	48.0 1.890	49.7 1.957

Millimeters Inches



POLAMCO Connector Savers

38999-Style Series III and Series IV Connectors

Part Numbering System

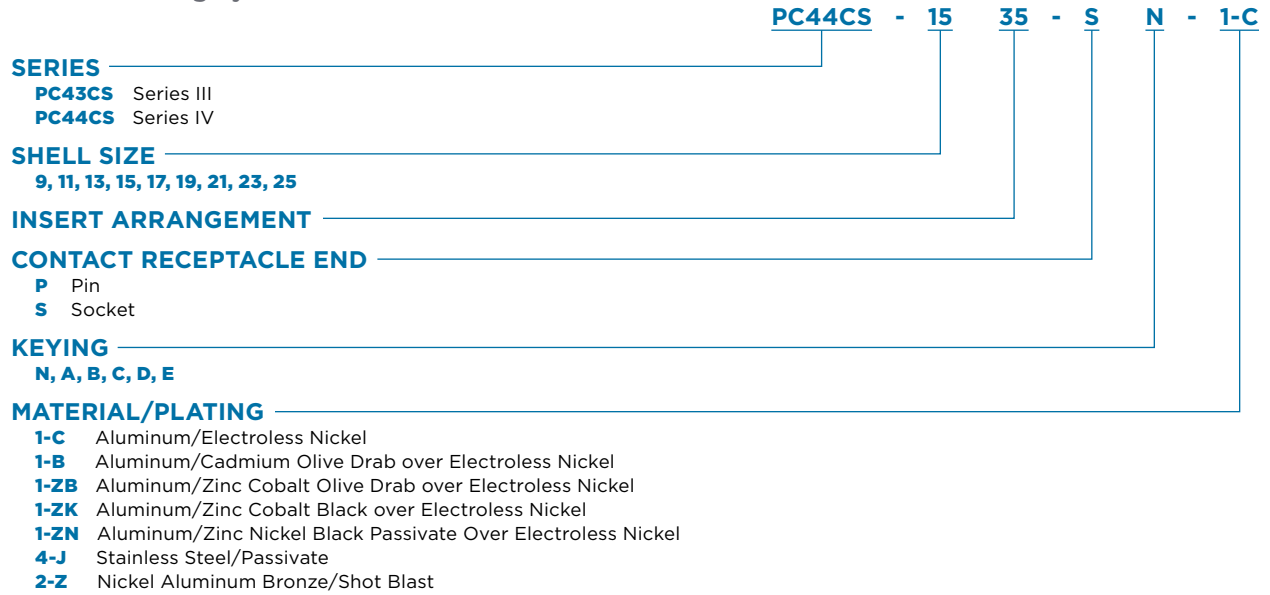



SIMPLE, RELIABLE WIRE BUSSING

- Internal pc board connects contacts for grounding distribution and power distribution
- Range of standard and custom bussing configurations

WEIGHT AND SPACE SAVING

- Composite and aluminum shells
- Eliminates external bussing components
- Shell sizes 9 through 25

DEUTSCH CBC Series Circuit Board Connectors



38999 Series III Style Connectors with Bussed Contacts

DEUTSCH CBC connectors contain an internal printed circuit board used to bus contacts. A number of bussing arrangements are available. The lightweight connectors are available with either composite or aluminum shells. They offer an integrated solution for bussing needs by eliminating the need for external components.

Specifications

- **Current:** Traces and sockets carry current levels up to the threshold of a: MS22073-3 circuit breaker for contact size 22
MS22073-5 circuit breaker for contact size 20
MS22073-7.5 circuit breaker for contact size 16
- **Conformal Coating:** per MIL-I-46058 and able to withstand 100 VDC for two seconds
- **Insulation Resistance:** greater than 100 megohms when tested at 45 VDC
- **Applicable Specifications:**
IPC-600C
IPC O-275
MIL-P-55110
MS22073
MIL-I-46058
MIL-STD-1560
- **Frequency:** maximum of 3200 Hz (analog circuit) and 100 kb/s (for ARINC 429 signals)
- **Circuit-to-Circuit Crosstalk Rejection:** minimum of 60 dB, nominal 80 dB
- **Temperature:** 125°C maximum continuous operating temperature for finished circuit board



DEUTSCH CBC Series Circuit Board Connectors

	CBC Connector Base Typical Part No.			
	59052	59108	66363	59091
Shell Sizes	13, 15, 19, 25	15	9, 11, 13, 15, 17, 19, 23, 25	25
Shell Material	Composite	Composite	Aluminum	Nickel-Plated Composite
Backpack Cover	Composite or Aluminum			Nickel-Plated Composite
Contacts	Copper Alloy			Copper Alloy
Contact Plating	DEUTSCH COAT V			Gold over Nickel
Resilient Inserts	Silicone Elastomers			
Plastic Inserts	Thermoplastic			

Dimensions

Shell Size	ØA Max.	ØB Max.
9	21.79 0.858	18.29 0.720
11	24.99 0.984	21.21 0.835
13	29.39 1.157	24.21 0.953
15	32.49 1.279	28.19 1.110
17	35.69 1.405	31.19 1.228
19	38.48 1.515	34.21 1.347
23	44.91 1.768	40.21 1.583
25	47.98 1.889	43.18 1.700

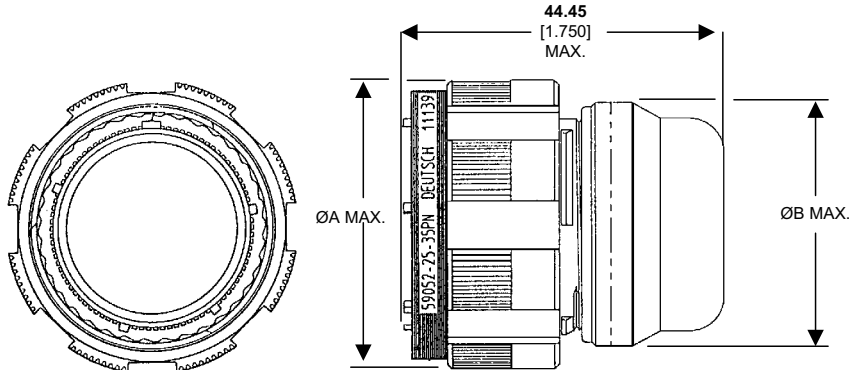

Millimeters Inches

Part Numbering

See each product family for availability of different options. Consult TE for configurations not shown here.

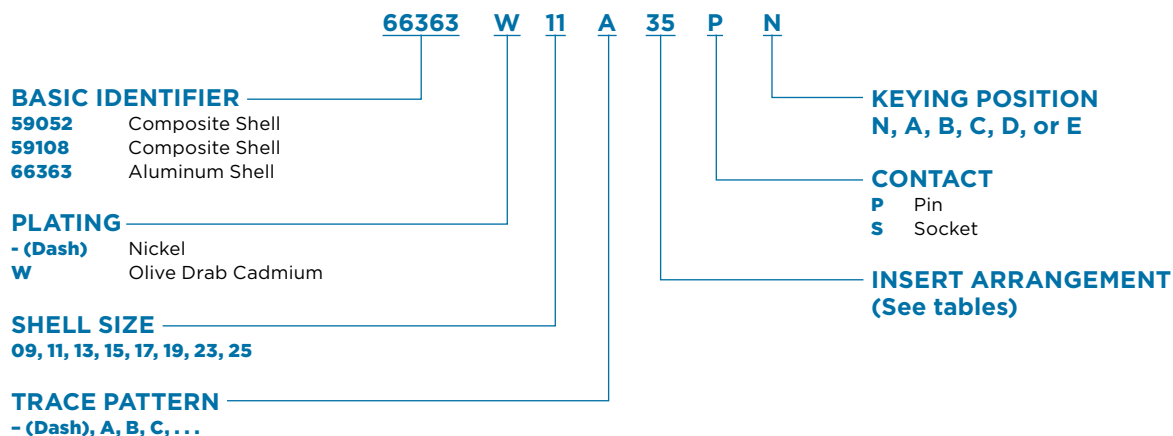



59052 Composite Plug

**Insert Arrangement 13-98
Trace Pattern A
Typical Part No. 59052-13A98PN**

Buss Size	Contact Numbers
2 Bussed Contacts	A, B C, F D, E
Spare	G, H, J, K

**Insert Arrangement 13-98
Trace Pattern B
Typical Part No. 59052-13B98PN**

Buss Size	Contact Numbers
2 Bussed Contacts	E, H F, G
3 Bussed Contacts	A, B, J
Spare	C, D, K

**Insert Arrangement 19-32
Trace Pattern A
Typical Part No. 59052-19A32SN**

Buss Size	Contact Numbers
3 Bussed Contacts	D, E, F
4 Bussed Contacts	U, V, W, X
5 Bussed Contacts	d, e, f, g, h
Spare	A, B, C, G, H J, K, L, M, N P, R, S, T, Y Z, a, b, c, j

**Insert Arrangement 25-04
Trace Pattern C
Typical Part No. 59052-25C04SA**

Buss Size	Contact Numbers
3 Bussed Contacts	M, N, P
4 Bussed Contacts	A, B, C, D DD, EE, FF, JJ
6 Bussed Contacts	E, F, G, J, K, L
Spare	H, R, S, T, U, V W, X, Y, Z, a, b c, d, e, l, g, h k, m, n, p, q, r s, l, u, v, w, x y, z, AA, BB, CC GG, HH, KK, LL

**Insert Arrangement 25-35
Trace Pattern - (Dash)
Typical Part No. 59052-25-35PN**

Buss Size	Contact Numbers
3 Bussed Contacts	1, 2, 3 4, 5, 6 8, 9, 10 11, 12, 13 14, 24, 35 23, 34, 46 47, 57, 58 59, 60, 61 62, 63, 64 65, 66, 67 68, 69, 70 80, 81, 93 92, 103, 113 104, 114, 121 115, 116, 117 118, 119, 120 122, 123, 124 125, 126, 127

4 Bussed Contacts	15, 16, 17, 18 19, 20, 21, 22 26, 27, 28, 29 30, 31, 32, 33 95, 96, 97, 98 99, 100, 101, 102 105, 106, 107, 108 109, 110, 111, 112
-------------------	---------------------------------------------------------------------------------------------------------------------------------------------------------

5 Bussed Contacts	25, 37, 38, 39, 40 41, 42, 43, 44, 45 36, 48, 49, 50, 51 52, 53, 54, 55, 56 82, 71, 72, 73, 74 75, 76, 77, 78, 79 94, 83, 84, 85, 86 87, 88, 89, 90, 91
-------------------	------------------------------------------------------------------------------------------------------------------------------------------------------------------------------

Spare	7, 28
-------	-------

**Insert Arrangement 25-61
Trace Pattern - (Dash)
Typical Part No. 59052-25-61PN**

Buss Size	Contact Numbers
4 Bussed Contacts	G, H, g, h J, l, y, z P, m, CC, MM R, n, DD, EE S, T, U, V W, X, Y, I Z, u, HH, JJ a, v, w, x p, q, r, s

5 Bussed Contacts	A, B, C, D, E, b, c, d, e, f K, L, j, AA, KK M, N, k, BB, LL
-------------------	-----------------------------------------------------------------------

Spare	F
-------	---



59108 Composite Plug

Insert Arrangement 15-35 Trace Pattern C 59108-15C35PN Bussing Arrangements	
Buss Size	Contact Numbers
21 Bussed Contacts	1, 2, 3, 4, 5, 6, 7, 8, 9, 10, 11, 12, 13, 14, 15, 16, 17, 18, 32, 33, 34
15 Bussed Contacts	19, 20, 21, 22, 23, 24, 25, 26, 27, 28, 29, 30, 31, 36, 37
Spare	35

66363 Aluminum

Insert Arrangement 09-35 Trace Pattern A Typical Part No. 66363W09A35PA	
Buss Size	Contact Numbers
2 Bussed Contacts	1, 2 3, 4
Spare	5, 6

Insert Arrangement 09-35 Trace Pattern B Typical Part No. 66363W09B35PN	
Buss Size	Contact Numbers
2 Bussed Contacts	1, 2 3, 4
Spare	5, 6

Insert Arrangement 09-35 Trace Pattern C Typical Part No. 66363W09C35PN	
Buss Size	Contact Numbers
2 Bussed Contacts	5, 6
Spare	1, 2, 3, 4

Insert Arrangement 11-35 Trace Pattern A Typical Part No. 66363W11A35PN	
Buss Size	Contact Numbers
3 Bussed Contacts	1, 3, 6 2, 4, 5 9, 10, 11
Spare	7, 8, 12, 13

Insert Arrangement 11-35 Trace Pattern B Typical Part No. 66363W11B35PN	
Buss Size	Contact Numbers
3 Bussed Contacts	1, 6, 8 2, 5, 7
2 Bussed Contacts	9, 10 11, 12
Spare	3, 4, 13

Insert Arrangement 11-35 Trace Pattern C Typical Part No. 66363W11C35PN	
Buss Size	Contact Numbers
2 Bussed Contacts	3, 7 4, 8 6, 10 5, 9
Spare	1, 2, 11, 12, 13

Insert Arrangement 11-35 Trace Pattern D Typical Part No. 66363W11D35PN	
Buss Size	Contact Numbers
3 Bussed Contacts	1, 7, 9 2, 8, 19
Spare	3, 4, 5, 6, 11, 12, 13

Insert Arrangement 11-35 Trace Pattern E Typical Part No. 66363W11E35PN	
Buss Size	Contact Numbers
2 Bussed Contacts	4, 10 5, 9
Spare	1, 2, 3, 6, 7, 8, 11, 12, 13



66363 Aluminum (continued)

Insert Arrangement 11-35 Trace Pattern F Typical Part No. 66363W11F35PN	
Buss Size	Contact Numbers
2 Bussed Contacts	1, 10
	2, 9
	3, 8
	4, 7
	5, 6
Spare	11, 12, 13
Insert Arrangement 15-35 Trace Pattern A Typical Part No. 66363W15A35PN	
Buss Size	Contact Numbers
2 Bussed Contacts	1, 7
	2, 11
	3, 15
4 Bussed Contacts	4, 8, 12, 16
	5, 9, 13, 17
	6, 10, 14, 18
Spare	19 through 37
Insert Arrangement 15-35 Trace Pattern B Typical Part No. 66363W15B35PN	
Buss Size	Contact Numbers
2 Bussed Contacts	4, 8, 12, 16
	5, 9, 13, 17
	6, 10, 14, 18
4 Bussed Contacts	4, 8, 12, 16
	5, 9, 13, 17
	6, 10, 14, 18
Spare	21 through 37
Insert Arrangement 17-35 Trace Pattern A Typical Part No. 66363W17A35PN	
Buss Size	Contact Numbers
2 Bussed Contacts	1, 33
	5, 34
	9, 35
	13, 36
	17, 37
	21, 38
	25, 39
	29, 40
	9 Bussed Contacts
Spare	44 through 55

Insert Arrangement 23-55 Trace Pattern A Typical Part No. 66363W23A55PN	
Buss Size	Contact Numbers
2 Bussed Contacts	D, V
	E, U
	F, T
	G, S
	H, R
	J, P
	K, N
	L, M
	w, z
	x, y
Spare	A, B, C, W, X, Y, Z, a, b, c, d, e, f, g, h, j, k, m, n, p, q, u, v, AA, BB, CC, DD, EE, FF, GG, HH, i, r, s, l, u
Insert Arrangement 23-55 Trace Pattern B Typical Part No. 66363W23B55PN	
Buss Size	Contact Numbers
2 Bussed Contacts	A, C
	M, d
	N, c
	S, b
	T, o
	P, Z
	R, Y
	U, X
	V, W
	e, p
y, AA	
z, BB	
Spare	B, D, E, F, G, H, J, K, L, q, n, r, h, u, w, x, CC, DD, FF, GG, HH, EE, m, s, k, l, j, v, f, g, i
Insert Arrangement 25-35 Trace Pattern A Typical Part No. 66363W25A35PN	
Buss Size	Contact Numbers
3 Bussed Contacts	54, 66, 77
	55, 67, 78
	61, 62, 63
	72, 73, 74
4 Bussed Contacts	52, 64, 75, 87
	53, 65, 76, 88
Spare	1 through 51, 56, 57, 58, 59, 60, 68, 69, 70, 71, 79 through 86, 89 through 128



MIL-DTL-38999 Circular Connectors

Assembly Instructions

Contact Crimping

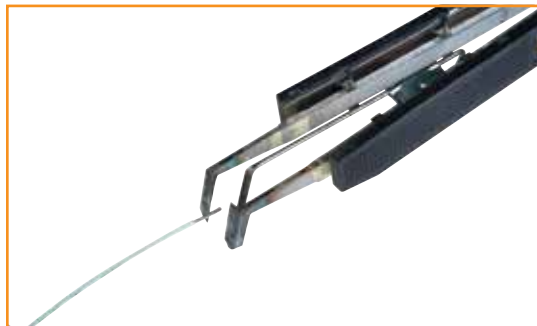

1 Burn through the insulation with a hot wire stripper or use other approved stripping method. Do not remove the insulation at this point. This will help protect the wire strands from splaying. Refer to contact information sheet for proper wire insulation strip length.



2 Set the dial of the crimp to the proper setting for wire gage and contact as noted on the contact information sheet or on the tool. Be sure that the proper locator is used. See contact information sheet for proper locator.



3 Drop the contact into the crimping tool with the contact crimp barrel facing up.

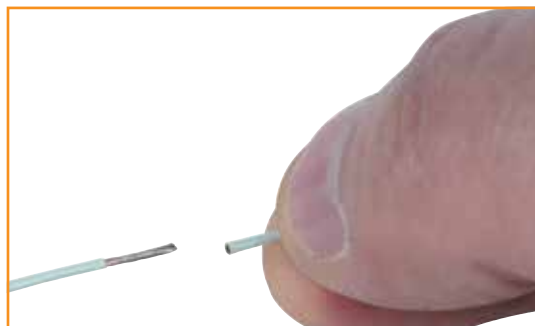

4 Remove the small piece of insulation from the wire. Do not pinch the insulation with the fingernails during this procedure. The wire is now ready to be crimped to the contact.

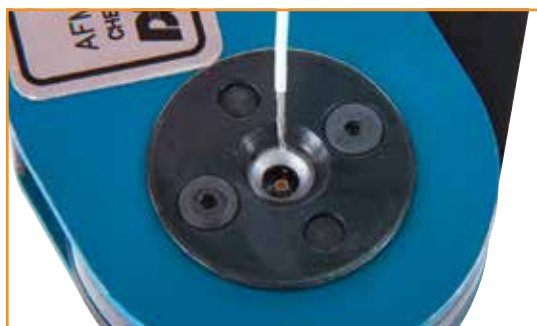

5 Insert the bare wire into the open end of the contact and squeeze the handles of the tool together. The crimping tool will not release until the full crimping cycle has been performed. Remove the crimped contact and wire from the tool.



6 Two series of 4 indents grip the wire and secure the contact to the wire. Visibility of the wire in the contact inspection hole (arrow) indicates that the wire is crimped into the contact at the proper depth. Inspect to make sure there are no loose or nicked strands.



Assembly Instructions

Contact Insertion

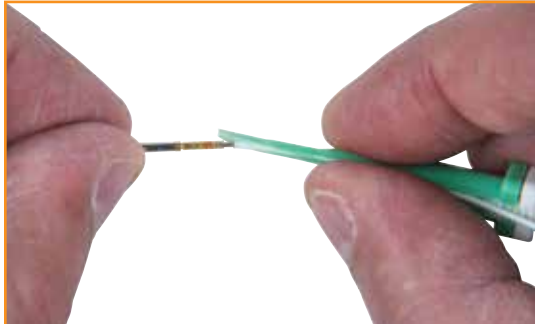

1 Hold the insertion half of the tool between the thumb and forefinger and lay the wire against the slot of the tool, then snap the wire into the slot.



2 After the wire snaps into the tool, seat the retention shoulder against the tip of the tool.



3 Holding the connector with the rear grommet facing you, slowly push the contact straight into the grommet cavity. Do not twist the tool. Note: Some wire constructions may not require the use of an insertion tool.



4 A firm stop will be evident when the contact positively seats in the connector. Remove the tool by sliding it back on the wire. The contact will now be securely locked in place.



Assembly Instructions

Contact Removal



1 With the rear of the connector facing you, lay the wire of the contact along the slot of the tool, leaving about 1/2" from the end of the tool to the rear of the connector. Squeeze the wire firmly into the tool between the thumb and forefinger about 1/2" from the tip and quickly pull the tool away from the connector.



2 The wire will now have snapped into place. Slide the tool down along the wire and into the rear cavity and slowly into the connector until a positive resistance is felt. At this time, the contact retaining mechanism is in the unlocked position.

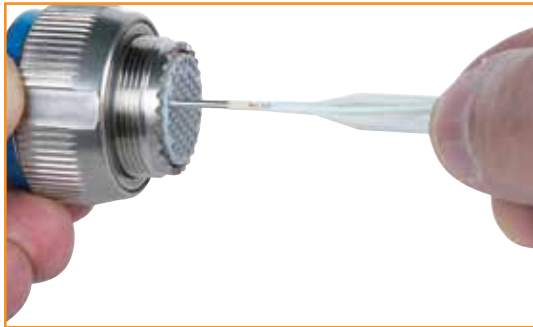

3 Press the wire of the contact against the serrations of the plastic tool and pull both the tool and the contact/wire assembly out of the connector.

Caution: When using minimum diameter wire, the tool may have a tendency to stop against the rear of the contact crimp barrel. If this should occur, careful manipulation of the tool will help permit it to ride over the crimp barrel and into the proper position to unlock the contact.

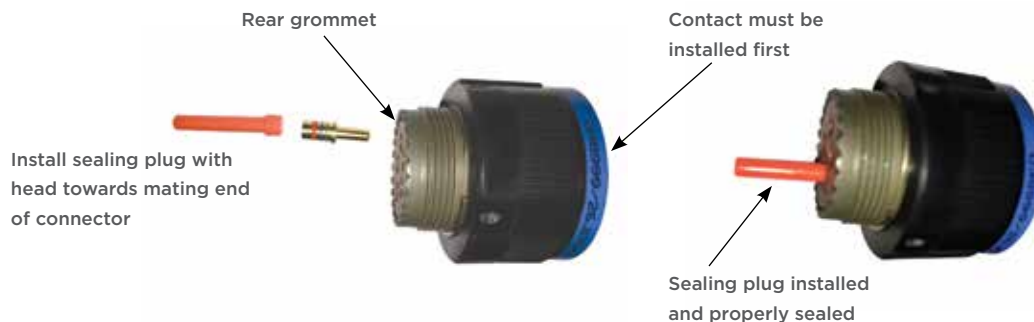



Notes

LET'S CONNECT

We make it easy to connect with our experts and are ready to provide all the support you need. Just call your local support number or visit www.te.com/industrial to chat with a Product Information Specialist.

Technical Support

te.com/support-center

North America	+1 800 522 6752	Asia Pacific	+86 400 820 6015
North America (Toll)	+1 717 986 7777	Japan	+81 044 844 8180
EMEA/South Africa	+800 0440 5100	Australia	+61 2 9554 2695
EMEA (Toll)	+31 73 624 6999	New Zealand	+64 (0) 9 634 4580
India (Toll-Free)	+800 440 5100		

Withstand Harsh Environments with Rugged, Capable Connectors for Signal, Power, Control, and Optical Needs



te.com/38999

AMP, AGASTAT, CeeLok FAS-X, CII, DEUTSCH, HARTMAN, HexaShield, KILOVAC, MICRODOT, NANONICS, POLAMCO, PRO BEAM, Raychem, SEACON, TE, TE Connectivity and the TE connectivity (logo) are trademarks of TE Connectivity. Other products, logos, and company names mentioned herein may be trademarks of their respective owners.

While TE Connectivity (TE) has made every reasonable effort to ensure the accuracy of the information herein, nothing herein constitutes any guarantee that such information is error-free, or any other representation, warranty or guarantee that the information is accurate, correct, reliable or current. The TE entity issuing this publication reserves the right to make any adjustments to the information contained herein at any time without notice. All implied warranties regarding the information contained herein, including, but not limited to, any implied warranties of merchantability or fitness for a particular purpose are expressly disclaimed. The dimensions herein are for reference purposes only and are subject to change without notice. Specifications are subject to change without notice.

Consult TE for the latest dimensions and design specifications.

© 2018 TE Connectivity. All Rights Reserved.

1-1773922-9 01/18

Mouser Electronics

Authorized Distributor

Click to View Pricing, Inventory, Delivery & Lifecycle Information:

TE Connectivity:

[D38999/27HF28PN](#) [D38999/21HH55SA](#) [D38999/23HB35SN](#) [D38999/27HF66SE](#) [D38999/23HD5PN](#)
[D38999/21HA35SN](#) [D38999/23HB99SC](#) [D38999/23HB35PB](#) [D38999/27HB13ZN](#) [D38999/21HG11SD](#)
[D38999/21HE55CD](#) [D38999/23HH1SC](#) [D38999/21HA6DE](#) [D38999/25HE55ZC](#) [D38999/27HE55DD](#)
[D38999/23HF28SE](#) [D38999/21HF32PB](#) [D38999/21HG39PB](#) [D38999/21HG16SA](#) [D38999/21HA6SA](#)
[D38999/21HC22SB](#) [D38999/23HB99SA](#) [D38999/21HA6DA](#) [D38999/25HA6XC](#) [D38999/23HG11SE](#)
[D38999/21HJ61PD](#) [D38999/21HB13PE](#) [D38999/23HF28PN](#) [D38999/23HE55SA](#) [D38999/23HH55SC](#)
[D38999/25HB13XA](#) [D38999/21HG1ZB](#) [D38999/23HB13XC](#) [D38999/21HD5SD](#) [D38999/23HB13DE](#)
[D38999/25HE55DE](#) [D38999/23HE6SB](#) [D38999/21HE55XA](#) [D38999/27HG1CB](#) [D38999/23HB35PE](#)
[D38999/23HJ24PN](#) [D38999/25HJ1ZA](#) [D38999/20ZA6PB](#) [D38999/23HD97SB](#) [D38999/21HF32PC](#) [D38999/21HD5PE](#)
[D38999/27HE55ZA](#) [D38999/21HJ35PE](#) [D38999/27HC22SE](#) [D38999/23HJ4SC](#) [D38999/25HH1ZD](#)
[D38999/23HD19SE](#) [D38999/21HJ4PN](#) [D38999/27HJ1CD](#) [D38999/23HA35SB](#) [D38999/23HC22PB](#)
[D38999/21HH1SA](#) [D38999/23HH55PC](#) [D38999/21HD18PN](#) [D38999/23HB98SB](#) [D38999/23HH53SA](#)
[D38999/27HA6CA](#) [D38999/23HJ43PC](#) [D38999/23HB13DC](#) [D38999/21HG35SD](#) [D38999/25HF66DB](#)
[D38999/21HJ1PA](#) [D38999/23HD5SB](#) [D38999/25HA6XE](#) [D38999/21HB5SA](#) [D38999/21HB13ZD](#) [D38999/21HH1ZA](#)
[D38999/23HH35SN](#) [D38999/21HH21PA](#) [D38999/21HE35PE](#) [D38999/21HH35PE](#) [D38999/21HE6PN](#)
[D38999/27HB13CE](#) [D38999/21HG16SB](#) [D38999/21HJ1XC](#) [D38999/23HE55SN](#) [D38999/23HD15SN](#)
[D38999/25HC22ZN](#) [D38999/25HB13DN](#) [D38999/23HC22SA](#) [D38999/23HC22XN](#) [D38999/27HC22PN](#)
[D38999/21HA6PB](#) [D38999/21HF32SA](#) [D38999/23HG1ZE](#) [D38999/25HJ1SB](#) [D38999/21HG35PN](#) [D38999/23HJ1ZA](#)
[D38999/25HC22DE](#) [D38999/21HJ29PB](#) [D38999/21HH21PD](#) [D38999/23HE35SE](#) [D38999/21HF32PD](#)
[D38999/23HA6ZC](#) [D38999/27HA6PB](#)